



Flexiheat UK
Heating and hot water solutions

www.flexiheatuk.com
01202 822221

Installation, Use and Maintenance Manual for models

R2K RAIN

R2K 24 RAIN H version with PX90

R2K 28 RAIN version with PX90

R2K 34 RAIN

Condensing boiler, with integrated heat exchanger for domestic hot water production, suitable for outdoor installation

CE 0476

SUMMARY

INTRODUCTION.....	4
-------------------	---

1. INSTALLER SECTION 7

1.1. INSTALLATION	8
1.1.1. GENERAL INSTALLATION WARNINGS.....	8
1.1.2. BOILER LOCATION ENVIRONMENTAL REQUIREMENTS.....	9
1.1.3. REFERENCE LEGISLATION.....	9
1.1.4. OVERALL DIMENSIONS.....	10
1.1.5. HYDRAULIC CONNECTIONS.....	10
1.1.6. POSITIONING AND MINIMAL TECHNICAL SPACES.....	11
1.1.7. PUMP HEAD / FLOW DIAGRAM.....	13
1.1.8. HYDRAULIC CONNECTION.....	15
1.1.9. SYSTEM FILLING.....	17
1.1.10. FILLING THE CONDENSATE DRAIN SYPHON.....	19
1.1.11. FROST PROTECTION.....	20
1.1.12. GAS CONNECTION.....	21
1.1.13. ELECTRICAL CONNECTION.....	21
1.1.14. OPTIONAL ELECTRICAL CONNECTIONS.....	23
1.1.15. FLUE SYSTEMS.....	26
1.1.16. INSTALLATION MODES.....	28
1.1.17. TYPE OF FLUE SYSTEM.....	30

2. SERVICE CENTRE SECTION 33

2.1. COMMISSIONING	34
2.1.1. COMMISSIONING PRELIMINARY OPERATIONS.....	34
2.1.2. BOILER COMMISSIONING.....	35
2.1.3. CO ₂ VALUE CHECK AND CALIBRATION (24 kW).....	36
2.1.4. CO ₂ VALUE CHECK AND CALIBRATION (28 kW / 34 kW).....	38

SUMMARY

2.1.5. ELECTRIC FAN FREQUENCY/HEAT CAPACITY DIAGRAM	40
2.2. MAINTENANCE	43
2.2.6. GENERAL MAINTENANCE WARNINGS	43
2.2.7. TECHNICAL DATA	45
2.2.8. TECHNICAL ASSEMBLY	55
2.2.9. HYDRAULIC DIAGRAM	58
2.2.10. WIRING DIAGRAM	59
2.2.11. ACCESSING THE BOILER	61
2.2.12. ACCESSING THE ELECTRONIC BOARD	62
2.2.13. SYSTEM EMPTYING	63
2.2.14. GAS CONVERSION (24 kW)	64
2.2.15. GAS CONVERSION (28 kW / 34 kW)	65

3. USER SECTION 67

3.1. USE	68
3.1.1. GENERAL USE WARNINGS	68
3.1.2. CONTROL PANEL	70
3.1.3. DISPLAY ICONS	71
3.1.4. INFO MENU DISPLAY DATA	73
3.1.5. START-UP	76
3.1.6. OPERATING MODE	76
3.1.7. INFORMATIONAL NOTE ON ANTI-FREEZE FUNCTION	78
3.1.8. SYSTEM FILLING	79
3.1.9. FAULT SIGNALLING CODES	80
3.1.10. ACTIVE FUNCTIONS SIGNALLING CODES	85
3.1.11. ECO FUNCTION	86
3.1.12. FAST H2O FUNCTION	86
3.1.13. MAINTENANCE	87
3.1.14. EXTERNAL CASING CLEANING	87
3.1.15. DISPOSAL	87

INTRODUCTION

WARNING

Before starting any operation it is mandatory to read this instruction manual, in relation to the activities to be carried out as described in each relevant section. Proper operation and optimal performance of the boiler are ensured by strict compliance with all the instructions given in this manual.

The installation, use and maintenance manual is an integral and essential part of the product and must be delivered to the user.

MANUAL USERS

The manual users are all those who install, use and maintain the boiler.

The boiler must be used and accessed only by qualified operators that fully read and understood the use and maintenance manual, paying particular attention to the warnings.

READING AND SYMBOLS OF THE MANUAL

To ease the understanding of this manual, recurrent symbols where used, in particular:

- › On the outer margin of the page is placed a thumb index indicating the type of user to which the

instructions in that section address.

- › The titles are differentiated by thickness and size in accordance with their hierarchy.
- › The images contain important parts described in the text, marked with numbers or letters.
- › (See chap. "chapter name"): this entry indicates another section in the Manual that you should refer to.
- › Device: this term is used referring to the boiler.



DANGER

It identifies an information related to a general danger that if not complied with, may cause serious personal damage or even death.



ATTENTION

It identifies an information that if not complied with may cause small or medium level lesions to the person or serious deterioration to the boiler.



WARNING

It identifies a precaution information that must be observed in

1. INTRODUCTION

order to avoid damaging the machine or parts of it.

MANUAL STORAGE

The manual must be carefully stored and replaced in case of deterioration and/or low legibility.

If you misplace the use and maintenance manual, you can request it from the Service Centre giving the serial number and model of the boiler indicated on the data plate placed on the right side of its casing.

As an alternative, the use and maintenance manual can be downloaded free of charge from the on-line site www.radiant.it, accessing the “download” section and entering the boiler model.

MANUFACTURER WARRANTY AND RESPONSIBILITY

The warranty of the Manufacturer is provided only through its own authorized Service Centres, listed on the official web site (www.radiant.it), and covers all conformity defects at the moment of sale.

The technical and functional features of the device are ensured by its use in compliance:

1. with the use and maintenance instructions contained in the manuals accompanying the product, the content of which the customer certifies that he is aware;
2. with the conditions and purposes to which devices of the same type are intended.

For more information on the warranty validity, its duration, the obligations and the exemptions, please consult the First start-up certificate attached to this manual.

The manufacturer reserves:

- > the right to modify the tools and relative technical documentation without any obligation to third parties; neither will the company be held responsible for any inaccuracies in this handbook deriving from printing or translation errors;

1. INTRODUCTION

- › the material and intellectual ownership of this manual and forbids its distribution and duplication, even partial, without prior written authorization.
- › with a quality certificate signed by the tester.

PRODUCT CONFORMITY

RADIANT BRUCIATORI spa declares that its gas boilers comply with the European Directives and with the requirements provided in the European standards below:

- › Eco-design Directive 2009/125 CE,
- › Energy labelling Directive 2010/30/CE,
- › Regulation EU 811/2013,
- › Regulation EU 813/2013,
- › Regulation EU 2016/426,
- › Electromagnetic compatibility Directive 2014/30/CE,
- › Performance Directive 92/42/CE,
- › Low voltage Directive 2014/35/CE.
- › EN15502-1:2021 + A1:2023
- › EN15502-2-1:2022 + A1:2023

The materials used such as copper, brass, stainless steel create a homogeneous, compact and functional assembly, easy to install and manage. In its simplicity, the boiler is equipped with all accessories necessary to render it a veritable independent heating unit. All boilers are tested and delivered

1. INSTALLER SECTION

The installation operations described in this section, must be performed only by qualified personnel, having the appropriate technical training in the field for the installation and maintenance of components of civil and industrial domestic hot water production and heating plants.

1. INSTALLATION

1.1. INSTALLATION

1.1.1. GENERAL INSTALLATION WARNINGS



ATTENTION

This boiler may be used only for the purpose for which it has been designed: heat water to a temperature below boiling point at atmospheric pressure. Any other use is considered wrong and dangerous. The manufacturer is excluded from any contractual or extra-contractual responsibility for damages caused to people, animals or property due to errors during installation.



ATTENTION

This boiler must be installed only by qualified personnel, having the appropriate technical training in the field for the installation and maintenance of components of civil and industrial domestic hot water production and heating plants.



ATTENTION

After having removed the packing, make sure the device is intact. In case of doubt, do not use the device and contact the supplier.

BEFORE INSTALLING THE BOILER, THE INSTALLER MUST MAKE SURE THAT THE FOLLOWING CONDITIONS ARE MET:

- › The device is connected to a heating system and a water supply network appropriate for its power and performance.
- › The location must be properly vented through an air vent.
- › The air vent must be placed at floor level to prevent it from being obstructed, protected by a grid that does not hamper the useful passage section.
- › The device is suitable for use with the type of gas available by checking the boiler data plate (placed on the inner side of the front casing).
- › Make sure that the pipes and joints are perfectly sealed, without any gas leaks.
- › Make sure that the grounding system works properly.
- › Make sure that the electrical system is suitable for the maximum power absorbed by the device, value indicated on the data plate.

1. INSTALLATION



WARNING

Use only original RADIANT optional or kit accessories (including ones).

1.1.2. BOILER LOCATION ENVIRONMENTAL REQUIREMENTS

The device installation location should be vented due to the presence of threaded joints on the gas supply line. The location should be therefore provided with vents as to ensure air exchange, with output grid in the natural accumulation area of potential gas losses.



WARNING

DO NOT install the boiler in a technical compartment near a swimming pool or a laundry, to avoid that the combustion air is exposed to chlorine, ammonia or alkaline agents that may worsen the corrosion phenomenon of the heat exchanger. Failure to observe this caution will void the warranty of the heat exchanger.

The ABS material boiler casing is approved for the exposition to atmospheric agents and, in particular, to UV rays.

THIS BOILER IS ABLE TO OPERATE WITHIN THE AMBIENT TEMPERATURES MINIMUM -10 °C AND MAXIMUM 60 °C.



WARNING

If the temperature in the appliance installation location goes below -10 centigrades, please fill the plant with anti-freeze liquid and insert and a frost protection kit (see chapter 'ANTI-FREEZE PROTECTION').



WARNING

The manufacturer will not be held responsible for damages caused by incorrect installation not in conformity with the above mentioned instructions and not duly protected from freeze.

1.1.3. REFERENCE LEGISLATION

The installation must be done according to the requirements of current legislation and in compliance with local technical regulations, according to the indications of the good technique.

1. INSTALLATION

1.1.4. OVERALL DIMENSIONS

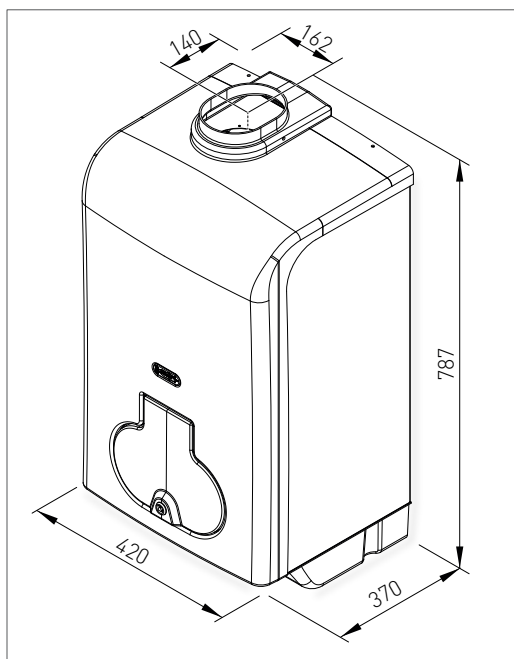

1.1.5. HYDRAULIC CONNECTIONS

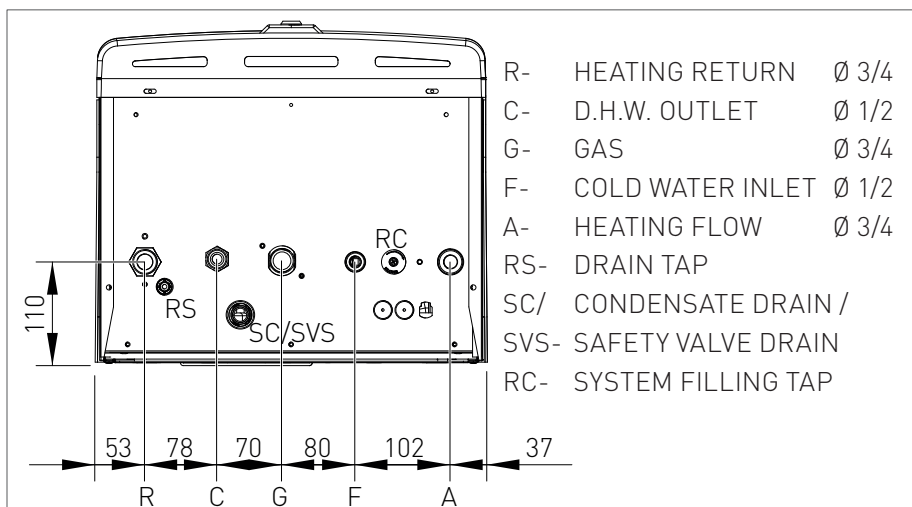

1. INSTALLATION

1.1.6. POSITIONING AND MINIMAL TECHNICAL SPACES

The boiler must be installed only on a vertical solid wall, able to sustain its weight.

In order to allow the access inside the boiler for maintenance operations, the minimum technical spaces indicated in figure 1 have to be respected.

Keep the same distances from flammable materials and wooden walls as well.

To facilitate the installation, the boiler is provided with wall template that allows setting in advance the connections to the pipes, offering the possibility to connect the boiler once masonry works are completed.

For boiler positioning, proceed as follows (see fig. 2):

1. Trace a line using a spirit level (min. length 25 cm) on the installation wall;
2. place the top of the template along the traced line respecting the distances of the water connections; then mark the two points to insert the two wall fastening screws, then trace the points for the flue system;

3. remove the template and drill the wall;
4. hang the boiler onto the wall fastening screws or onto the wall hanging bracket and perform the connections.

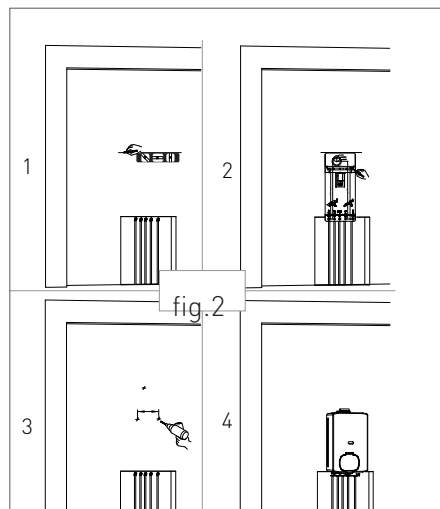
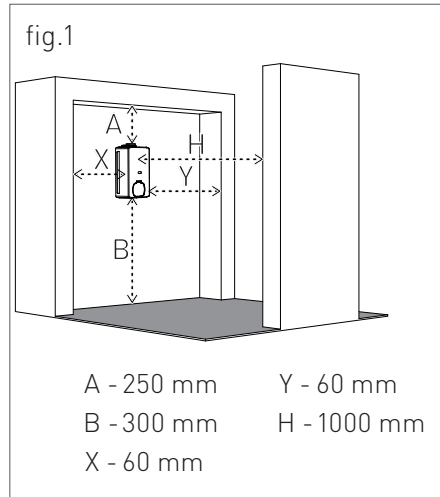

1. INSTALLATION



WARNING

Make sure, using a spirit level, that the boiler is properly inclined being levelled (see fig.3) so as to allow the condensate to drain.



WARNING

The incorrect slopes of the device can cause the incorrect discharge of condensate by means of the discharge duct with consequent condensate stagnation inside the condensate module.

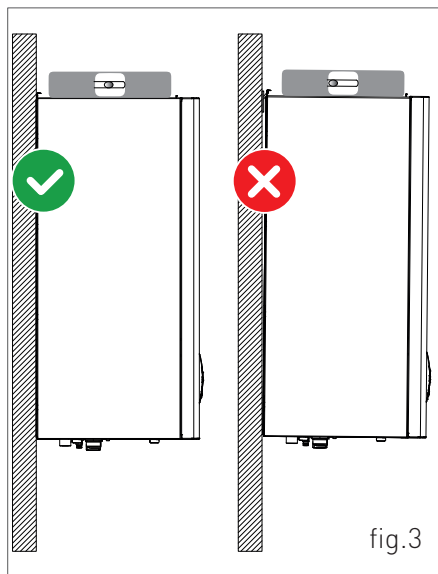
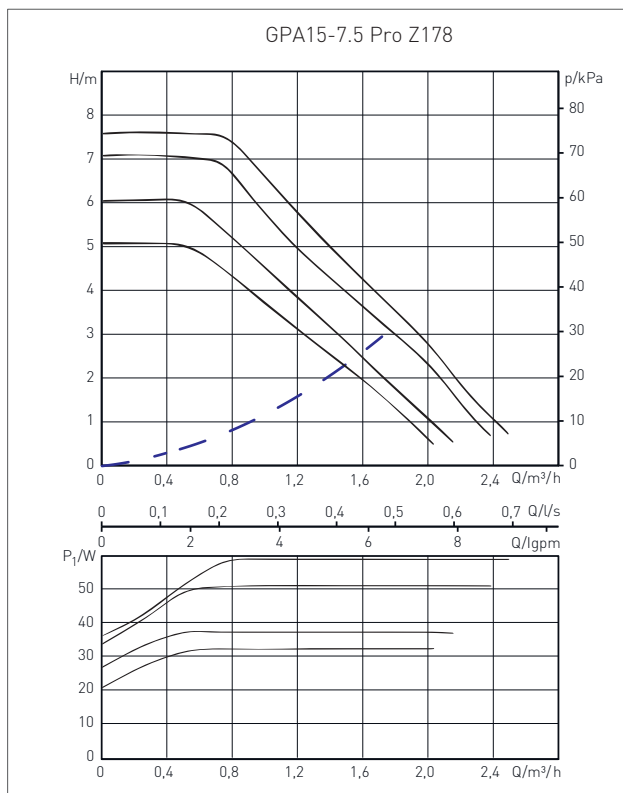
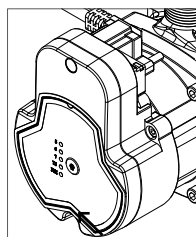

fig.3

1.1.7. PUMP HEAD / FLOW DIAGRAM



--- Appliance head losses



Fixed head selection button at maximum speed
(It disables the control from the PWM)

1. INSTALLATION

Error Code	Description
All LEDs flash simultaneously 1 time	Overvoltage protection. The pump will start again after the voltage drops below the protection limit (overvoltage limit: $270\pm 5V$).
All LEDs flash simultaneously 2 times	Undervoltage protection. The pump will start again after the voltage rises above the protection limit (undervoltage limit: $165\pm 5V$).
All LEDs flash simultaneously 3 times	Overcurrent protection. The pump attempts to restart after every 8s.
All LEDs flash simultaneously 4 times	Phase-loss protection. The pump attempts to restart after every 8s.
All LEDs flash simultaneously 5 times	Lockout protection due to impeller jammed or slowed down by impurities. Check and solve the problem. The pump attempts to restart after every 8s.
All LEDs flash simultaneously 6 times	Protection against lack of water or air in the system. The pump attempts to restart after every 8s.
All LEDs flash simultaneously 7 times	Over-temperature protection. The pump will start up again after its operating temperature falls below the protection limit for 5s.

1. INSTALLATION

1.1.8. HYDRAULIC CONNECTION



DANGER

Make sure that the water and heating pipes are not used as grounding system for the electrical plant. They are not suitable for such use.



WARNING

To prevent voiding the warranty and ensure proper operation of the boiler, please wash the system (if possible when hot) with suitable pickling or descaling solutions in order to remove the impurities coming from pipes and radiators.



WARNING

If the boiler is installed in a hydrostatic position lower than those of the connected devices (radiators, fan coils, etc.), install the shut-off valves on the D.H.W. and heating circuits to ease the performance of the maintenance operations, if it is necessary only to empty the boiler.



WARNING

When connecting the boiler to water supply, avoid excessive bending and recovery operations from any off axis positioning that may

damage the pipes causing leaks, malfunction or early wear.



WARNING

In order to avoid any vibrations and noises, do not use pipes with small diameters or elbows with small radius and significant cut-off of the passage sections.



WARNING

Connect the boiler safety drains to a discharge funnel. The manufacturer is not responsible for any floods due to safety valve opening in case of plant overpressure.

D.H.W. CIRCUIT



WARNING

In order to avoid any limescale and damages to the D.H.W. heat exchanger, the domestic inlet water should be treated in accordance with the legislation in force. According to the D.P.R. 59/09, it is mandatory to treat the water over 15° French for domestic water, by means of chemical (according to UNI 8065) conditioning treatment for powers < 100 kW or softening treatment for powers > 100 kW. Moreover, it is necessary to install a protection security filter of the system.

1. INSTALLATION



WARNING

The pressure of the cold inlet water should be between 0.5 and 6 bar. In case of higher pressure values, please install a pressure reducer upstream from the boiler.

property for failure to comply with these instructions.

HEATING CIRCUIT



WARNING

In order to avoid any scale or deposits on the primary exchanger, the heating circuit inlet water should be treated in accordance with the legislation in force. According to the D.P.R. 59/09, it is mandatory to treat the water over 25° French for the heating circuit by means of chemical (according to UNI 8065) conditioning treatment for powers < 100 kW or softening treatment for powers > 100 kW. Moreover, it is necessary to install a protection security filter of the system.



WARNING

In case the boiler is installed as part of a low temperature circuit, please install a safety thermostat on the heating flow, which can stop the boiler activity in case of high heating flow temperature. The company assumes no liability for damages caused to persons or

1. INSTALLATION

1.1.9. SYSTEM FILLING



WARNING

For system filling use only clean tap water.



WARNING

If the system is filled by adding ethylene glycol-type chemical agents, the installation of a hydraulic separator on the loading system is recommended, in order to separate the heating circuit from the D.H.W. circuit.

Before powering up the boiler, fill the system as follows:

1. slightly loosen the cap of the pump air vent valve (1-fig. 1) to release the air from the system;
2. slightly loosen the cap of the air vent valve placed on top of the condensing exchanger (fig. 3) to release the air from the top of the system;
3. open the filling tap "R" (fig. 2);
4. release all the air;
5. use pressure gauge "M" (fig. 2) to make sure that the system pressure reaches 1.2 bar (fig. 4);
6. after performing this operation, make sure that the filling tap "R" (fig. 2) is properly closed.
7. open the air relief valves of the radiators and check the air

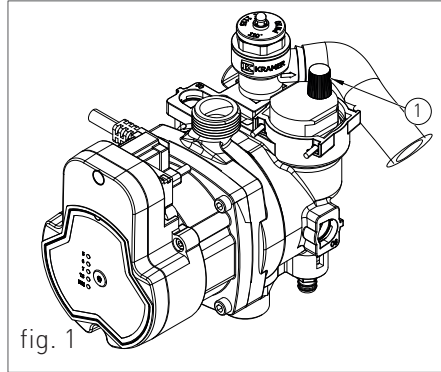

fig. 1

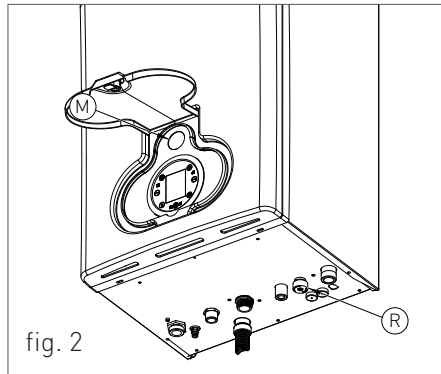

fig. 2

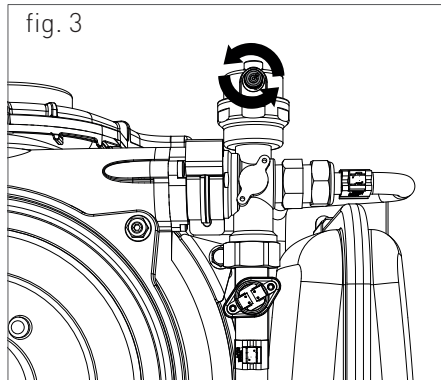

fig. 3

1. INSTALLATION

8. removal process. **WHEN THE WATER COMES OUT, CLOSE THE RADIATOR AIR VENT VALVES AND THE AIR VENT VALVE LOCATED IN THE UPPER RIGHT PART OF THE CONDENSING EXCHANGER (FIG. 3).**
9. If after performing these operations, there is a decrease of the water pressure inside the system, open the filling tap "R" once again, until the pressure gauge indicates the value of 1.2 bar (fig. 4).

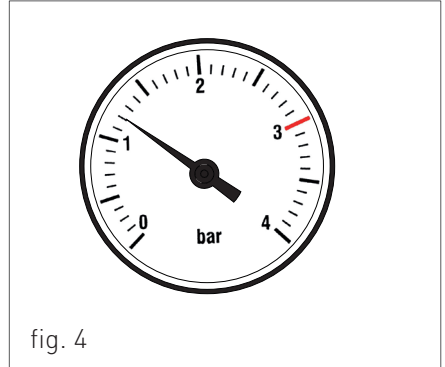

fig. 4

1.1.10. FILLING THE CONDENSATE DRAIN SYPHON

Before starting the boiler, it is necessary to fill the condensate drain syphon in order to prevent backflow of flue gases through the syphon itself.

Fill the condensate drain syphon as follows:

- › With a glass pour the water in the heat exchanger's flue exhaust duct outlet (see fig. 5), up to fill the condensate syphon to the highest point "T" (fig. 5);
- › Connect the dedicated flexible condensate draining pipe to a waste disposal system. The condensate can be drained directly in the sewerage system by inserting an easily serviceable syphon.

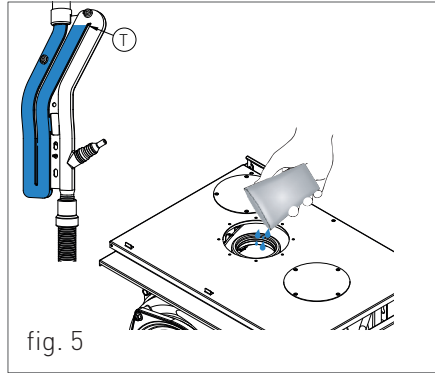

1. INSTALLATION

1.1.11. FROST PROTECTION

The boiler is protected against freezing thanks to the P.C.B. configuration with functions that start the burner and heat the concerned parts when their temperature goes below the minimum pre-set values, protecting the boiler up to an external temperature of -10 °C.

The boiler starts when the heating water temperature goes below 8 °C (this value can be modified through parameter P31), automatically starting the burner until the heating flow water temperature reaches the 30°C and, in presence of a return sensor, until the heating return water temperature reaches the 20°C.

The system starts even if on the display appears "OFF", as long as the boiler is connected to the power (230 V) and gas supply.

For long periods of standby, please empty the boiler and the system.

If the temperature goes below -10° centigrades, please fill the system with anti-freeze liquid (CLEANPASS FLUIDO AG cod. 98716LA) and insert a frost protection kit (cod. 82259LP).

CLEANPASS DILUTION PERCENTAGE	FLUIDO AG
----------------------------------	--------------

ANTI-FREEZE - PROPYLENE GLYCOL	FREEZING POINT
--------------------------------------	-------------------

(%) VOLUME	(°C)
------------	------

20	-7.5
----	------

30	-13
----	-----

35	-18
----	-----

40	- 22.5
----	--------

45	-28
----	-----

50	-33.5
----	-------

55	-42
----	-----

60	-50
----	-----

RECOMMENDED GLYCOL PERCENTAGE: 20 %	MINIMUM
--	---------

1.1.12. GAS CONNECTION



DANGER

In order to connect the boiler gas connector to the supply pipe, use a stop seal of an appropriate size and material. The use of hemp, teflon tape or similar materials is strictly forbidden.



WARNING

That the boiler is intended exclusively to be installed on a gas supply with a meter with gas pressure regulator, where applicable.

BEFORE PERFORMING THE GAS CONNECTION, MAKE SURE THAT:

- › the gas supply line complies with the standards and regulations in force;
- › the piping section suits the requested capacity and its length;
- › the piping is equipped with all safety and control devices required by the standards in force;
- › the internal and external seals of the gas inlet system are checked;
- › the boiler is suitable for use with the available type of gas by checking the boiler data plate (placed on the inner side of the front casing. If they do not match, please take the necessary measures to adapt the boiler to another type of gas (see chapter GAS CONVERSION);
- › the gas supply pressure falls within the values indicated on the data plate.

1.1.13. ELECTRICAL CONNECTION



DANGER

The boiler is electrically safe only if it is properly connected to an efficient earthing system, performed in compliance with the safety standards in force. Check this essential safety requirement is strictly recommended. If in doubt, request an accurate check of the electrical system performed by qualified staff, as the manufacturer is not responsible for any damages caused by lack of earthing system.

1. INSTALLATION

- › Make sure that the electrical systems is suitable for the maximum power absorbed by the boiler, value indicated on the data plate.
- › make sure that the cables section is appropriate for the maximum power absorbed by the boiler and that it is however not lower than 1 mm².
- › The equipment works with alternating current of 230 V and 50 Hz. The electrical connection must be performed using an all-pole switch with an opening of at least 3 millimetres between contacts placed upstream from the device.



WARNING

Make sure that the live and neutral cables connection is performed in compliance with the wiring diagram (see chapter POWER SUPPLY).



WARNING

It is strictly forbidden the use of adaptors, multiple plugs and/or extensions for the general power supply of the boiler from the electrical network.

1. INSTALLATION

1.1.14. OPTIONAL ELECTRICAL CONNECTIONS

The cables should be inserted inside the boiler using the fairleads 'P1' and 'P2' placed on the hydraulic connections bottom plate (see fig. 1). Make a hole on the fairlead, smaller than the cable diameter, to make sure that the air cannot pass through.

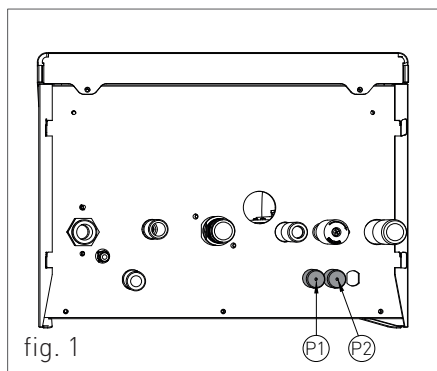

To wire the optional items below:

- **(TA) ROOM THERMOSTAT**
- **(CR) OPEN THERM REMOTE CONTROL**

operate on the 'ME' clamp (see fig.2 and fig.3) which is outside the control panel, as follows:

- > For the Room Thermostat (TA) or Remote Control (CR) first remove the jumper on the contacts

and then connect the two non-polarised leads on the contacts.

To wire the optional items below:

- **(SE) OUTDOOR TEMPERATURE SENSOR CODE 73518LA**
- **(RA) CONTACT CABLE COD. 40-00788 FOR: AUXILIARY RELAY FOR GENERIC DEVICE. MAXIMUM CURRENT 3A WITH 250VAC. FOR THE CONNECTION TO THE ZONE VALVE, SEE THE DIAGRAM IN FIGURE NO. 3 (SEE RELAY MANAGEMENT AT PARAMETER P34)**
- **(ID1) CONTACT FOR: SECONDARY ROOM THERMOSTAT / EXCLUSION OF DHW OR HEATING VIA CLOCK (SEE CONTACT MANAGEMENT IN PARAMETER P36)**

- **(ID2) CONTACT CABLE COD. 40-00751 FOR: EXCLUSION OF DHW OR HEATING VIA CLOCK (SEE CONTACT MANAGEMENT IN PARAMETER P37).**

- **(IAC) CONFIGURABLE ANALOGUE INPUT FOR: AUXILIARY PROBE CABLE ENABLING / 0-10V (SEE CONTACT MANAGEMENT IN PARAMETER P48).**

1. INSTALLATION

operate on the P.C.B. placed inside the control panel as follows:



DANGER

Cut off the voltage from the main switch.

- › remove the boiler front casing (refer to chapter ACCESSING THE BOILER).

- › remove the control panel back plate (see chapter ACCESSING THE P.C.B.).
- › after removing the back plate, connect the items below to the P.C.B. (see fig. 2).

NB: In case of simultaneous presence of outdoor sensor and remote control, the main P.C.B. only sends the external temperature value to the remote device without using it for modulation. The communication between P.C.B. and the remote control takes place independently from the boiler's operating mode and after establishing the connection, the user interface on the P.C.B. is disabled and the display shows the symbol

After performing these operations, remount the back plate and the front casing.

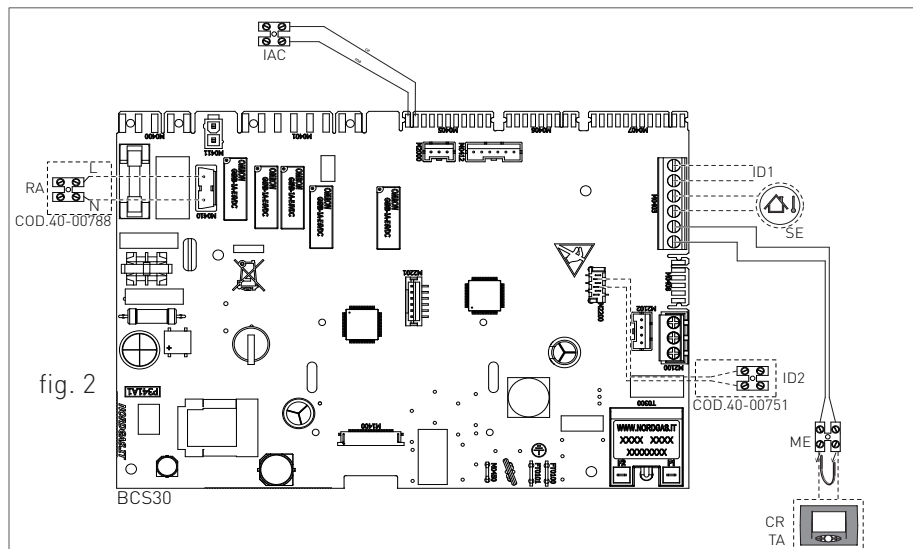

fig. 2

1. INSTALLATION

ZONE VALVE CONNECTION CONTROLLED BY THE REMOTE CONTROL (VZR) THROUGH THE CABLE CODE 40-00788 AND ZONE VALVES' LIMIT SWITCH (FC) CONTROLLED BY THE ROOM THERMOSTAT

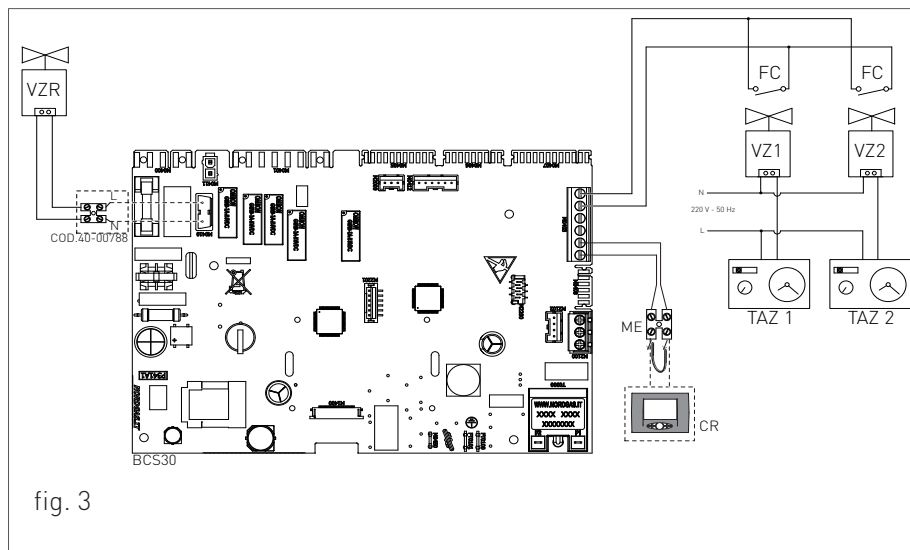

fig. 3

INSTALLER

1. INSTALLATION

1.1.15. FLUE SYSTEMS



WARNING

To ensure correct operation and perfect efficiency values of the appliance, it is essential to connect the boiler flue exhaust pipe to the flue exhaust duct using dedicated polypropylene flue kits and accessories for condensing boilers. It is recommended to install Radiant approved flue systems.



WARNING

Conventional (aluminium) flue components cannot be used for the flue exhaust of condensing boilers, nor vice versa.



WARNING

For fumes exhaust and condensate collection, please follow the technical standards in force.

- › For all discharge ducts, with regard to the fumes path, you should provide an uphill slope (outwards) so as to favour the reflux of the condensate towards the combustion chamber, suitably realized to collect and drain acid condensate.
- › For all air suction ducts, with regard to the air path, you should provide an uphill slope (towards

the boiler) so as to avoid the protrusion inside the duct of rain water, dust or foreign objects.

- › In case of horizontal co-axial system installation, correctly place the horizontal co-axial terminal suitably realized to respect the slopes inside the fumes duct and to protect the air suction duct from adverse weather conditions.
- › When a vertical flue system is installed, insert a condensate drain syphon at the base of the pipe, connected to the house/building sewage system (fig. 1).

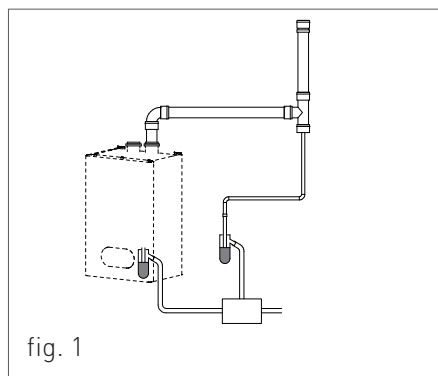

1. INSTALLATION

- > In order to discharge the fumes through a fumes exhaust duct carefully follow the technical standards in force.
- > Make sure that the discharge tube does not protrude inside the fumes exhaust duct, stop before it reaches the inner surface of the latter.
- > The discharge duct must be perpendicular with the opposite internal wall of the chimney or of the fumes exhaust duct (fig. 2).

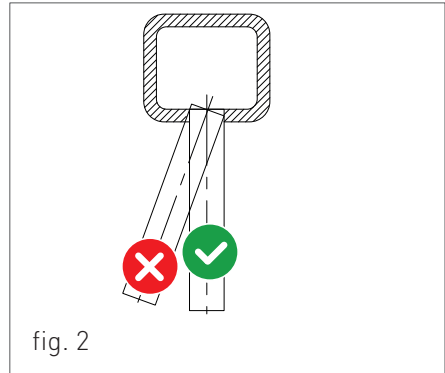

1. INSTALLATION

1.1.16. INSTALLATION MODES

For this type of boiler, the following flue exhaust configurations are available: A3, B23, B23p, B33, B53 and C13 (see Fig. 1).

- › A3- Outdoor air intake and outdoor flue exhaust.
- › B23- Indoor air intake and outdoor flue exhaust.
- › B23P- Indoor air intake and outdoor flue exhaust, with exhaust system operating under pressure.
- › B33- Indoor air intake and flue exhaust duct.
- › B53- Indoor air intake and flue exhaust through own fumes exhaust duct.
- › C13- Wall concentric flue exhaust. The pipes can be split but the outputs must be concentric or close enough to each other to undertake similar wind conditions (within 50 cm).

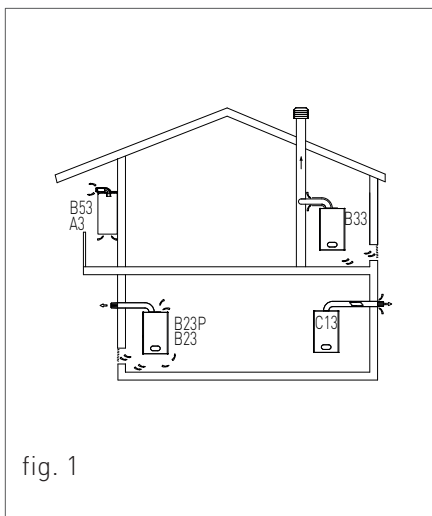

fig. 1

EXHAUST OF COMBUSTION PRODUCTS FOR B-TYPE DEVICES

Gas boilers, provided with connection for flue exhaust pipe, must be directly connected to efficient chimneys or flue exhaust ducts: only if these are missing the combustion products can be exhausted outside directly through the boiler itself.

The connection to the chimney or to the fume exhaust ducts must respect the following requirements:

- Be sealed and made of materials suitable to resist normal mechanical stress, heat, the action of combustion products and any condensate forming;
- have no more than three changes in direction, including the

1. INSTALLATION

chimney and/or fume exhaust duct inlet connection, made with internal angles greater than 90°. The changes in direction must be made only by using curved elements;

- have the axis of the inlet end perpendicular to the internal wall opposite to the chimney or fume exhaust duct;
- have, along its entire length, a section equal to or greater than that of the connection of the device discharge pipe;
- have no shut-off devices (shutters).
- for direct outdoor discharge there must be no more than two changes in direction.

LOCATIONS VENTING FOR B-TYPE DEVICES

The locations in which the gas boiler are installed gas devices must be vented so as to ensure the amount of air necessary for a regular combustion and for location ventilation. The natural air intake must take place directly through:

- permanent openings on the external walls of the location;
- single or collective, ramified ventilation ducts.

The openings on the external walls of the location must respect the following requirements:

- have a net overall free passage section of at least 6 cm² for every kW of heat capacity installed with a minimum of 100 cm²;
- they must be made so as to make sure that the opening inlets are not obstructed (neither indoor nor outdoor);
- they must be protected with grids, metal meshes, etc. so as to keep the useful section mentioned above.
- they must be placed at a height next to the floor level such as to allow proper operation of the combustion products discharge systems; if such position can not be obtained, please increase by at least 50% the section of the vents.

1. INSTALLATION

1.1.17. TYPE OF FLUE SYSTEM

KIT RAIN - Ø 80 HORIZONTAL POLYPROPYLENE PIPE. OUTSIDE INSTALLATION

It allows the flue exhaust through the pipe and the air intake from the environment.

Suitable for condensing boilers only. It allows the combustion gas exhaust through a polypropylene pipe and the combustion air intake directly from the hole situated on the room sealed chamber plate protected by a metal net.

PLEASE SEE THE MAXIMUM EXHAUST LENGTH IN THE TABLE IN CHAPTER "TECHNICAL DATA".

The maximum exhaust length (or linear length) can be calculated summing the length of the linear pipe and the equivalent length of each flue bend additional to the first one.

For the further addition of a bend, the linear length must be updated according to the indications below:

Flue bend $\text{Ø}80$ to 90° = 1.5 m

Flue bend $\text{Ø}80$ to 45° = 0.8 m

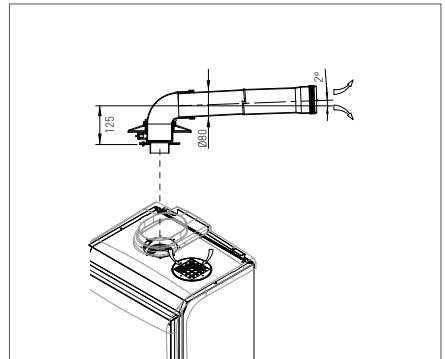
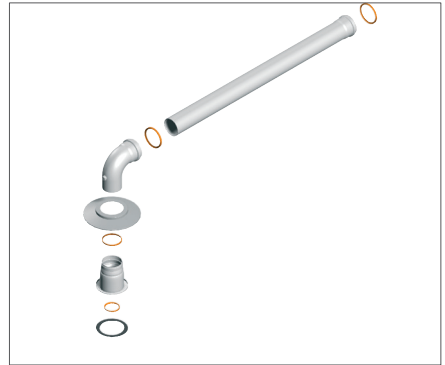

1. INSTALLATION

KIT RAIN L - Ø 80 VERTICAL POLYPROPYLENE PIPE. OUTSIDE INSTALLATION

It allows the flue exhaust from the roof e and the air intake from the environment.

Suitable for condensing boilers only. It allows the combustion gas exhaust through a polypropylene pipe and the combustion air intake directly from the hole situated on the room sealed chamber plate protected by a metal net.

PLEASE SEE THE MAXIMUM EXHAUST LENGTH IN THE TABLE IN CHAPTER "TECHNICAL DATA".

The maximum exhaust length (or linear length) can be calculated summing the length of the linear pipe and the equivalent length of each flue bend additional to the first one.

For the further addition of a bend, the linear length must be updated according to the indications below:

Flue bend $\text{Ø}80$ to 90° = 1.5 m

Flue bend $\text{Ø}80$ to 45° = 0.8 m

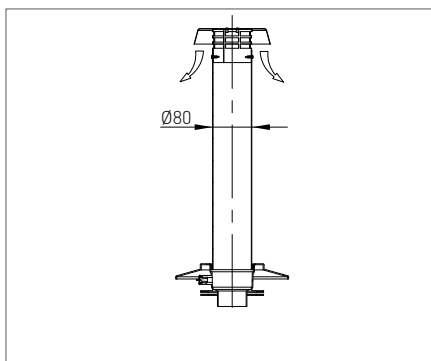
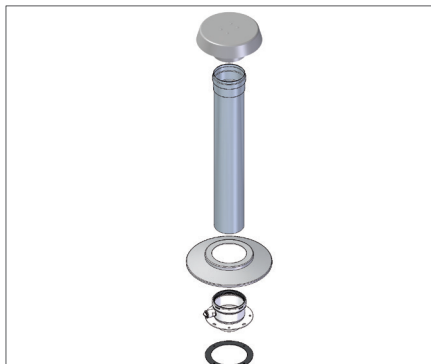

INSTALLER

1. INSTALLATION

FRONTAL FLUE KIT FOR RAIN SERIES - Ø 60 POLYPROPYLENE HORIZONTAL PIPE FOR OUTDOOR INSTALLATIONS WITHOUT FLUE CHIMNEY.

Suitable for condensing boilers only. It allows the outside combustion flues discharge through a polypropylene pipe, and the air intake directly from the hole which is situated on the room sealed chamber plate, which is protected by a wire mesh.

PLEASE NOTE: during the flue analysis tests, place the analyser inside the frontal flue kit terminal slots 'F' (fig. 2).

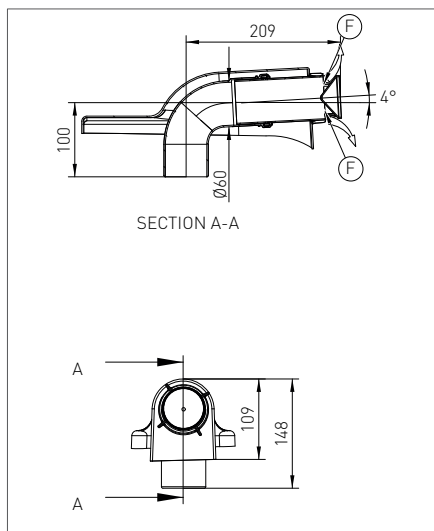
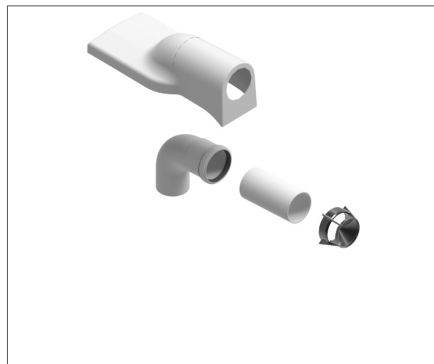

1. SERVICE CENTRE SECTION

All operations described below relative to first start-up, maintenance and replacement should be performed only by qualified personnel

2.1. COMMISSIONING

2.1.1. COMMISSIONING PRELIMINARY OPERATIONS

The commissioning operations consist in checking the correct installation, setting and operation of the device. Proceed as follows:

- › check the inner system sealing in accordance with the indications provided by standard and regulations in force;
- › check if the gas used is suitable for the boiler;
- › check if the gas capacity and relative pressures comply with those on the data plate;
- › check the intervention of the safety device in case of lack of gas;
- › make sure that the device supply voltage corresponds with that on the data plate (230 V – 50 Hz) and that the wiring is correct;
- › make sure that the grounding system works properly;
- › make sure that the combustion air supply and the flues and condensate discharge take place properly in compliance with the Local and National Laws and Standards in force;
- › make sure that the flue kit and its connection to the flue exhaust duct comply with the requirements of the Local and National Laws and Standards;
- › make sure that the heating system shut-off valves are open;
- › make sure that there is no intake of gaseous combustion products within the system;
- › make sure that there are no flammable liquids or materials near the device;
- › open the boiler gas tap and make sure that there are no gas leaks upstream from the device (the burner gas connection must be checked while the boiler is running);
- › in case of new installation of the gas supply network, the air inside the pipes may block the device at its commissioning. You might have to repeat the start-up procedure to purge all the air inside the pipe.

2.1.2. BOILER COMMISSIONING



WARNING

Make sure that the system is correctly filled.



Proceed with boiler commissioning as follows:

Make sure the gas feed valve is switched off

> Power the boiler.

THE START-UP SYSTEM WILL AUTOMATICALLY ACTIVATE THE SYSTEM AIR RELIEF CYCLE FUNCTION DISPLAYED ON SCREEN WITH CODE "F33" (ONLY AT FIRST START-UP WILL LAST FOR 5 MINUTES*). When function "F33" is active, the pump is enabled and the burner start-up request is disabled. The boiler can work normally only after completing the operation.

- > Make sure the circulating pump is unblocked.
- > If it should be blocked, wait for the circulating pump to activate the automatic reset (lasting 2 min.)
- > If the circulating pump should be still blocked, activate the circulating pump automatic reset again (further 2 minutes), and switch off the power supply and switch it on again.
- > Open the gas tap.

- > Use the button  to select the desired operation mode. If the symbol is displayed fixed, it means that the function has been activated.
- > The burner will start as soon as the thermostat contact is closed ;
- > If the flame is missing, the board will repeat the start-up operations after post-ventilation.
- > You might have to repeat the start-up operation several times to release all the air inside the gas tube. Before repeating the operation, wait at least 5 seconds from the last start-up attempt and unlock the boiler from "E01" error code by pressing the Reset  key.

(*) The boiler performs the system venting cycle function (5 minutes) only during the first starting. After every water pressure reset the boiler will automatically perform a reduced system venting cycle (2 minutes). During this function the display shows F33 code. The correct boiler operation will be allowed only after this operation has been completed.

2. FIRST START-UP

2.1.3. CO₂ VALUE CHECK AND CALIBRATION (24 kW)



WARNING

The CO₂ value should be checked with the casing assembled, while the gas valve should be adjusted with the casing open.

To check and calibrate the CO₂ value to minimum and maximum heating power proceed as follows:

FOR MINIMUM HEATING POWER

- › Activate the chimney sweeper function (F07) by keeping pressed the key  for 7 seconds (the maximum time of this function is 15 minutes).
- › Insert the fumes analyser probe in the suitable 'PF' fumes inlet (fig. 1), then make sure that the CO₂ value complies with the requirements indicated in chapter "Technical data", otherwise adjust using a 40 Torx wrench the screw '2' (fig. 2) of the Off-Set adjuster. To increase the CO₂ value, turn the screw clockwise and vice-versa if you want to decrease it.

fig. 1

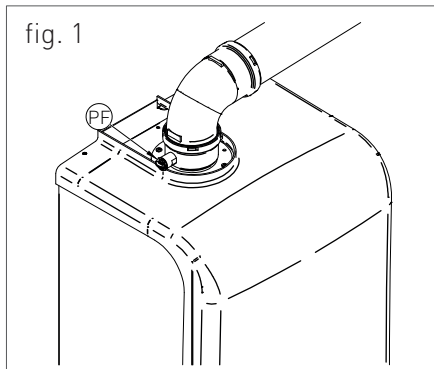
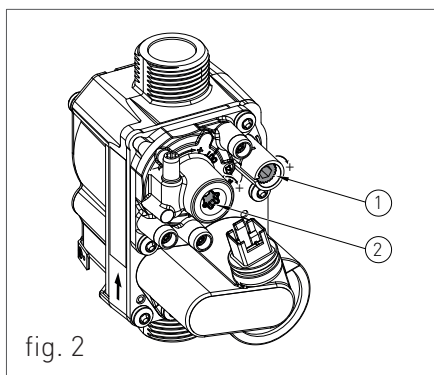







fig. 2



FOR MAXIMUM HEATING POWER

- › Press the key  of the heating temperature setting , to adjust the maximum heating power.
- › Make sure that the CO₂ value complies with the indications in "Technical data", otherwise adjust using a 4 Allen wrench the screw '1' (fig. 2) of the gas flow adjuster. To increase the CO₂ value, turn the screw clockwise and vice-versa if you want to decrease it.
- › After each adjustment variation on screw '1' (fig. 2) of the gas flow adjuster you have to wait for the boiler to stabilize itself to the set value (about 30 seconds).
- › Press the key  of the heating temperature setting  and make sure that the CO₂ value did not change to minimum, if changed repeat the calibration described in the previous paragraph.
- › Deactivate the chimney sweeper function by selecting the OFF mode by using the key .

2. FIRST START-UP

2.1.4. CO₂ VALUE CHECK AND CALIBRATION (28 kW / 34 kW)



WARNING

The CO₂ value should be checked with the casing assembled, while the gas valve should be adjusted with the casing open.

To check and calibrate the CO₂ value to minimum and maximum heating power proceed as follows:

FOR MINIMUM HEATING POWER

- › Activate the chimney sweeper function (F07) by keeping pressed the key  for 7 seconds (the maximum time of this function is 15 minutes).
- › Insert the fumes analyser probe in the suitable 'PF' fumes inlet (fig. 1), then make sure that the CO₂ value complies with the requirements indicated in chapter "Technical data", otherwise unscrew the protection screw 'A' (fig. 2) and adjust using a 4 Allen wrench the screw '2' (fig. 2) of the Off-Set adjuster. To increase the CO₂ value, turn the screw clockwise and vice-versa if you want to decrease it. Once completed the adjustment, tighten

the protection screw 'A' (fig. 2) on the Off-Set adjuster.

fig. 1

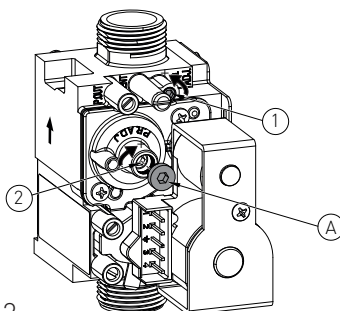
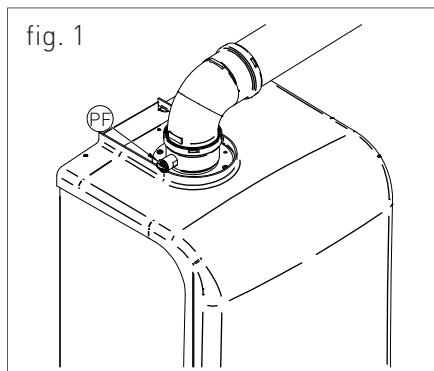







fig. 2

FOR MAXIMUM HEATING POWER

- › Press the key  of the heating temperature setting , to adjust the maximum heating power.
- › Make sure that the CO₂ value complies with the indications in "Technical data", otherwise adjust using screw '1' (fig. 2) of the gas flow adjuster. To increase the CO₂ value, turn the screw anti-clockwise and vice-versa if you want to decrease it.
- › After each adjustment variation on screw '1' (fig. 2) of the gas flow adjuster you have to wait for the boiler to stabilize itself to the set value (about 30 seconds)..
- › Press the key  of the heating temperature setting  and make sure that the CO₂ value did not change to minimum, if changed repeat the calibration described in the previous paragraph.
- › Deactivate the chimney sweeper function by selecting the OFF mode by using the key .

2. FIRST START-UP

2.1.5. ELECTRIC FAN FREQUENCY/HEAT CAPACITY DIAGRAM

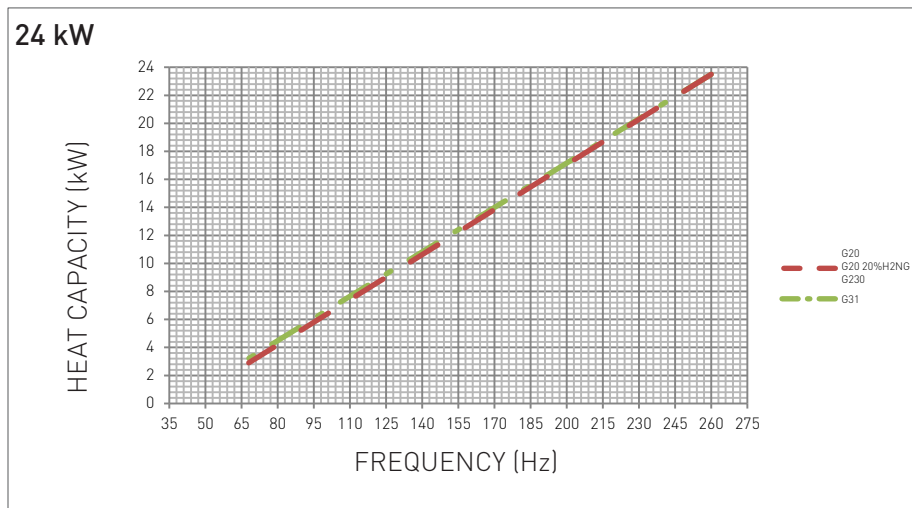

GAS TYPE		MINIMUM FREQUENCY	MAXIMUM FREQUENCY	STARTING STEP ADJUSTMENT
G20	Hz	68	260	150
G20 20%H2NG	Hz	68	260	
G31	Hz	65	260	
G230	Hz	68	260	

2. FIRST START-UP

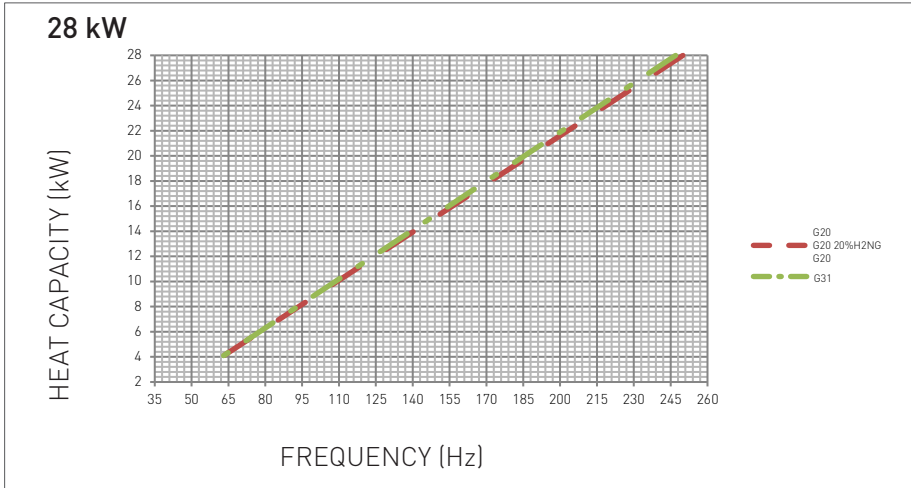

GAS TYPE		MINIMUM FREQUENCY	MAXIMUM FREQUENCY	STARTING STEP ADJUSTMENT
G20	Hz	60	250	150
G20 20%H2NG	Hz	60	250	
G31	Hz	60	247	
G230	Hz	60	250	

2. FIRST START-UP

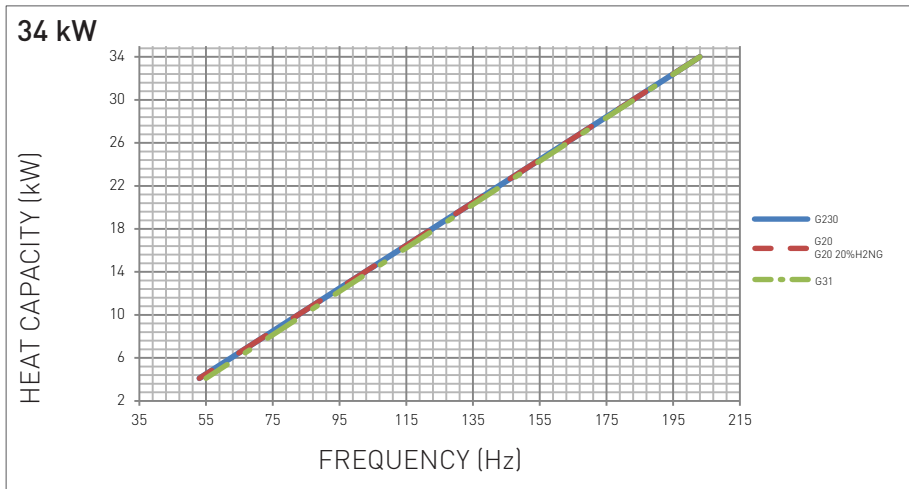

SERVICE CENTRE

GAS TYPE		MINIMUM FREQUENCY	MAXIMUM FREQUENCY	STARTING STEP ADJUSTMENT
G20	Hz	53	203	110
G20 20%H2NG	Hz	53	203	110
G31	Hz	55	203	130
G230	Hz	53	203	110

2.2. MAINTENANCE

2.2.6. GENERAL MAINTENANCE WARNINGS



DANGER

Before each components cleaning or replacement operation, ALWAYS cut off the POWER, WATER and GAS supply of the boiler.



WARNING

To ensure greater life span and proper operation of the device, during the maintenance operations use only original spare parts.



ATTENTION

To ensure the efficiency and safety of the device, the maintenance operations must be realized on an annual basis. The operations described below, are essential to the validity of the standard RADIANT warranty and must be performed by professionally qualified personnel in accordance with current legislation and authorized by RADIANT.

Please perform the following operations once a year:

- > Check that the system's water PH is between 6.5 and 8.5;
- > check the pre-load pressure of the expansion vessel;
- > check the sealing of the water components, and replace if necessary the gaskets;
- > check that the wiring is performed in compliance with the requirements in the boiler instruction manual;
- > check the wiring inside the control panel;
- > remove and clean the burner from oxidation;
- > check the integrity and the position of the sealed chamber sealing gasket;
- > check the primary exchanger, if necessary, clean it;
- > check the operation of the gas light up and safety systems. If necessary, remove and clean the flame detection and light up electrodes from incrustations paying attention to respect the distances with respect to the burner;
- > check the sealing of the gas components, and replace if necessary the gaskets;
- > visually check the flame and the condition of the combustion chamber;

2. MAINTENANCE



DANGER

> Verify that the concentration of CO in the flue gas does not exceed 400 ppm, otherwise an immediate verification and repair is required. If the situation cannot be resolved immediately, the appliance must be put out of operation.

- > if necessary make sure that the combustion is suitably adjusted and if required proceed as indicated in section "CO₂ VALUE CHECK AND CALIBRATION";
- > periodically check the integrity of the fume exhaustion system for safety and proper operation;
- > make sure that the permanent ventilation outlets are present, correctly sized and functioning, based on the installed devices. Respect the requirements provided by Local and National legislation;
- > check the heating circuit safety systems: limit temperature safety thermostat; limit pressure safety;
- > check the proper operation of the condensate draining system, including the devices outside the boiler such as condensate collection devices installed along the path of the fume exhaust duct or neutralization devices for acid condensate. Check that the liquid

flow is not obstructed and that there are no combustion gas refluxes inside the internal system;

- > check the flow and temperature of domestic hot water.

2. MAINTENANCE

2.2.7. TECHNICAL DATA

Modello		R2K 24 Rain H	R2K 28 Rain	R2K 34 Rain
CE certification	no.	0476CQ0134		
Gas category	0	II2HMY203P		
Flue system type	type	A3-B23-B23p-B33-B53-C13		
Energy efficiency 92/42 CEE	no . stars	4	4	4
Energy efficiency EN13203-1	no . stars	3	3	-
Heat Input max (C.H.)	kW	23,50	28	34
Heat Input max (D.H.W.)	kW	23,50	28	34
Heat Input min (C.H.)	kW	2,90	3,70	4,10
Heat Input min (D.H.W.)	kW	2,90	3,70	4,10
Heat Input min LPG	kW	2,90	3,70	4,10
Heat Input max (C.H.) 20%H2NG	kW	22,50	26,00	32,00
Heat Input max (D.H.W.) 20%H2NG	kW	22,50	26,00	32,00
Heat Input min (C.H.) 20%H2NG	kW	2,90	3,50	3,90
Heat Input min (D.H.W.) 20%H2NG	kW	2,90	3,50	3,90
Heat Output max. - 60/80°C	kW	22,94	27,30	33,35
Heat Output min. - 60/80°C	kW	2,75	3,52	3,94
Heat Output max. - 30/50°C	kW	24,79	29,40	36,19
Heat Output min. - 30/50°C	kW	3,02	3,83	4,34
Heat Output max at 30% Heat Input average - return 30°C	kW	4,26	5,12	6,21
Efficiency at 100% Heat Input - 60/80°C	%	97,60%	97,50%	98,08%
Efficiency at 30% Heat Input - return 30°C	%	107,60%	107,80%	108,00%
Heat Input average efficiency - 60/80°C	%	97,20%	96,80%	98,02%
Heat Output max at 30% Heat Input average - return 47°C	%	-	-	102,14%
Efficiency at 30% Heat Input average - return 30°C	%	107,70%	107,70%	108,60%

2. MAINTENANCE

Modello		R2K 24 Rain H	R2K 28 Rain	R2K 34 Rain
Efficiency Heat Output min. - 60/80°C	%	94,70%	95,00%	96,06%
Efficiency at 100% Heat Input - 30/50°C	%	105,50%	105,00%	106,43%
Efficiency Heat Output min - 30/50°C	%	104,20%	103,60%	105,91%
Maximum combustion efficiency	%	97,80%	97,70%	97,60%
Minimum combustion efficiency	%	98,10%	98,20%	97,90%
Flue efficiency losses with burner on (Heat Input max.)	%	2,20%	2,30%	2,40%
Flue efficiency losses with burner on (Heat Input min.)	%	1,90%	1,80%	2,10%
Flue temperature - Heat Input max.	°C	64,30	68,17	69,40
Flue temperature - Heat Input min.	°C	58,50	60,70	61,30
Maximum flue temperature	°C	102,00	102,00	102,00
CO2 - Heat Input max. - G20	%	9,30 - 9,10%	9,30 - 9,10%	9,45 - 9,25%
CO2 - Heat Input min. - G20	%	9,00 - 8,80%	9,00 - 8,80%	9,05 - 8,85%
CO2 - Heat Input max. - G20 20%H2NG	%	8,3 - 7,9%	8,4 - 8,0%	8,4 - 8,0%
CO2 - Heat Input min. - G20 20%H2NG	%	8,1 - 7,7%	8,0 - 7,6%	8,0 - 7,6%
O2 - Heat Input max. - G20 20%H2NG	%	5,4 - 6,1%	5,1 - 5,7%	5,1 - 5,8%
O2 - Heat Input min. - G20 20%H2NG	%	5,8 - 6,5%	5,7 - 6,6%	5,9 - 6,6%
CO2 - Heat Input max. - G31	%	10,40 - 10,20%	10,40 - 10,20%	10,55 - 10,35%
CO2 - Heat Input min. - G31	%	10,00 - 9,80%	9,95 - 9,85%	9,90 - 9,70%
CO2 - Heat Input max. - G230	%	10,20 - 10,00%	10,20 - 10,00%	10,20 - 10,00%
CO2 - Heat Input min. - G230	%	9,90 - 9,70%	9,90 - 9,70%	9,90 - 9,70%
CO - Heat Input max.	ppm	77	60	75
CO - Heat Input min.	ppm	1	1	2
Weighted CO [0% O2]	ppm	5	5	7

2. MAINTENANCE

Modello		R2K 24 Rain H	R2K 28 Rain	R2K 34 Rain
Casing efficiency losses (Heat Input max.)	%	0,20%	0,20%	-0,48%
Casing efficiency losses (Heat Input min.)	%	-	3,20%	1,84%
Fumes mass - Heat Input max.	g/s	10,38	12,37	14,96
Fumes mass - Heat Input min.	g/s	1,26	1,78	1,88
NOx class	class	6	6	6
Weighted NOx [0% O2] ppm	ppm	20	21	31
Weighted NOx [0% O2] on GCV mg/kWh	m g / kWh	32	36	49

Central heating circuit

Temperature setting - Central heating	°C	30-80 / 25-45	30-80 / 25-45	30-80 / 25-45
Max. operating temperature - Central heating	°C	80	80	80
Max. operating pressure - Central heating	bar	3	3	3
Min. operating pressure - Central heating	bar	0,3	0,3	0,3
Expansion vessel pre-charge pressure	bar	1	1	1
Expansion vessel capacity [C.H.]	litres	8	8	8

Domestic Hot Water (D.H.W.) circuit

Temperature setting - D.H.W.	°C	35-60	35-60	35-60
Max. operating pressure - D.H.W.	bar	6	6	6
Min. operating pressure - D.H.W.	bar	0,5	0,5	0,5
D.H.W. flow rate - continuous flow - Δt 25°C	litres/ min	13,5	16,1	19,5
D.H.W. flow rate - continuous flow - Δt 30°C	litres/ min	11,2	13,4	16,2
D.H.W. flow rate - continuous flow - Δt 35°C	litres/ min	9,6	11,5	13,9

2. MAINTENANCE

Modello		R2K 24 Rain H	R2K 28 Rain	R2K 34 Rain
Dimensions				
Width	mm	420	420	420
Depth	mm	370	370	370
Height	mm	787	787	787
Gross weight	Kg	36,4	37,8	39,4
Hydraulic Connections				
C.H. Flow	∅	3/4"	3/4"	3/4"
Cold water inlet	∅	1/2"	1/2"	1/2"
D.H.W. outlet	∅	1/2"	1/2"	1/2"
Gas	∅	3/4"	3/4"	3/4"
C.H. Return	∅	3/4"	3/4"	3/4"
Flue systems				
Fan - Max. available pressure	Pa	200	76	91
Fan - Min. available pressure	Pa	21	4	5,8
Flue bend 45° MF Ø60/100 - Pressure loss	m	0,6	-	-
Flue bend 90° MF Ø60/100 - Pressure loss	m	1	-	-
Flue extension MF Ø60/100 L=1000 - Pressure loss	m	1	-	-
Flue bend 45° MF Ø80/125 - Pressure loss	m	0,5	-	-
Flue bend 90° MF Ø80/125 - Pressure loss	m	0,8	-	-
Flue extension MF Ø80/125 L=1000 - Pressure loss	m	1	-	-
Max. Flue length Ø50/50 - Horiz. Twin	m	-	12	-
Max. Flue length Ø60/60 - Horiz. Twin	m	-	20	-
Flue adapter Ø80/60 MF - Pressure loss	m	0,4	0,4	0,4
Flue bend 45° MF Ø60 - Pressure loss	m	0,8	0,8	0,8
Flue bend 90° MF Ø60 - Pressure loss	m	1,5	1,5	1,5

2. MAINTENANCE

Modello		R2K 24 Rain H	R2K 28 Rain	R2K 34 Rain
Flue extension MF Ø60 L=1000 - m		1	1	1
Pressure loss				
T-connection MF Ø60 - Pressure loss	m	3,5	3,5	3,5
Max Flue length Ø80/80 - Horiz. Twin	m	-	60	-
Max. Flue length Ø50 - Horiz. Pipe	m	24	10	3
Max. Flue length Ø60 - Horiz. Pipe	m	40	18	14
Max. Flue length Ø80 - Horiz. Pipe	m	70	35	35
Flue bend 45° MF Ø80 - Pressure loss	m	0,8	0,8	0,8
Flue bend 90° MF Ø80 - Pressure loss	m	1,5	1,5	1,5
Flue extension MF Ø80 L=1000 - m		1	1	1
Pressure loss				
T-connection MF Ø80 - Pressure loss	m	3,5	3,5	3,5
Max. Flue length Ø60/100 - Vert. Conc.	m	-	6	-
Max. Flue length Ø80/125 - Vert. Conc.	m	-	8	-
Max. Flue length Ø50/50 - Vert. Twin	m	-	12	-
Max. Flue length Ø60/60 - Vert. Twin	m	-	20	-
Max. Flue length Ø80/80 - Vert. Twin	m	-	60	-
Max. Flue length Ø50 - Vert. Pipe	m	24	10	3
Max. Flue length Ø60 - Vert. Pipe	m	40	18	14
Max. Flue length Ø80 - Vert. Pipe	m	70	35	35
.Electrical specifications	0			
Voltage-frequency	V/Hz	220- 230/50	220- 230/50	220- 230/50
Nominal power consumption	A	0,62	0,62	0,62
Electric power with boiler OFF	W	3.50	3.50	3.50
Max Power consumption	W	78	78	78
Max Power consumption - boiler pump (100%)	W	40	40	40
Max Power consumption - boiler pump (55%)	W	25	25	25
Max Power consumption - fan	W	34	34	34

2. MAINTENANCE

Modello		R2K 24 Rain H	R2K 28 Rain	R2K 34 Rain
Protection rating	IP	X5D	X5D	X5D
Gas supply				
Supply pressure - G20	mbar	20	20	20
Supply pressure min. - G20	mbar	17	17	17
Supply pressure max. - G20	mbar	25	25	25
Fan speed Max. HEATING output - G20	Hz	260	250	203
Fan speed Max. D.H.W. output - G20	Hz	260	250	203
Fan speed Min. HEATING output - G20	Hz	55	60	50
Fan speed Min. D.H.W. output - G20	Hz	68	60	50
Gas consumption - G20	m ³ /h	2,49	2,96	3,60
Supply pressure - G20 20%H2NG	mbar	20	20	20
Supply pressure min. - G20 20%H2NG	mbar	17	17	17
Supply pressure max. - G20 20%H2NG	mbar	25	25	25
Fan speed Max. HEATING output - G20 20%H2NG	Hz	260	250	203
Fan speed Max. D.H.W. output - G20 20%H2NG	Hz	260	250	203
Fan speed Min. HEATING output - G20 20%H2NG	Hz	68	60	50
Fan speed Min. D.H.W. output - G20 20%H2NG	Hz	68	60	50
Gas consumption - G20 20%H2NG	m ³ /h	2,77	3,20	3,94
Supply pressure - G31	mbar	37	37	37
Supply pressure min. - G31	mbar	25	25	25
Supply pressure max. - G31	mbar	45	45	45
Fan speed Max. HEATING output - G31	Hz	260	247	203
Fan speed Max. D.H.W. output - G31	Hz	260	247	203
Fan speed Min. HEATING output - G31	Hz	65	60	53
Fan speed Min. D.H.W. output - G31	Hz	65	60	53
Gas consumption - G31	kg/h	1,83	2,17	2,64
Supply pressure - G230	mbar	20	20	20

2. MAINTENANCE

Modello		R2K 24 Rain H	R2K 28 Rain	R2K 34 Rain
Supply pressure min. - G230	mbar	17	17	17
Supply pressure max. - G230	mbar	25	25	25
Fan speed Max. HEATING output - G230	Hz	260	250	203
Fan speed Max. D.H.W. output - G230	Hz	260	250	203
Fan speed Min. HEATING output - G230	Hz	68	60	53
Fan speed Min. D.H.W. output - G230	Hz	68	60	53
Gas consumption - G230	m ³ /h	1,93	2,30	2,79

2. MAINTENANCE

Technical parameters for boiler space heaters, boiler combination heaters and cogeneration space heaters

Model		R2K 24	R2K 28	R2K 34
		Rain H	Rain	Rain
Condensing boiler	[yes/no]	yes	yes	yes
Low-temperature (**) boiler:	[yes/no]	no	no	no
B11 boiler	[yes/no]	no	no	no
Cogeneration space heater	[yes/no]	no	no	no
If yes, equipped with a supplementary heater	[yes/no]	no	no	no
Combination heater	[yes/no]	yes	yes	yes
Rated heat output P_{rated}	kW	23	27	33
For boiler space heaters and boiler combination heaters: Useful heat output				
At rated heat output and high-temperature regime (*) P_4	kW	22,9	27,3	33,3
At 30 % of rated heat output and low-temperature regime (**) P_1	kW	7,6	9,1	11,0
For cogeneration space heaters: Useful heat output				
At rated heat output of cogeneration space heater with supplementary heater disabled $P_{CHP100+Sup0}$	kW	-	-	-
At rated heat output of cogeneration space heater with supplementary heater enabled $P_{CHP100+Sup100}$	kW	-	-	-
For cogeneration space heaters: Electrical efficiency				
At rated heat output of cogeneration space heater with supplementary heater disabled $\eta_{el,CHP100+Sup0}$	%	-	-	-

2. MAINTENANCE

Model		R2K 24	R2K 28	R2K 34
		Rain H	Rain	Rain
At rated heat output of cogeneration space heater with supplementary heater enabled	%	-	-	-
$\eta_{el,CHP100+Sup100}$				
Auxiliary electricity consumption				
At full load elmax	kW	0,038	0,038	0,038
At part load elmin	kW	0,016	0,016	0,016
In standby mode PSB	kW	0,004	0,004	0,004
Seasonal space heating energy efficiency	%	94	94	94
η_s				
Seasonal space heating energy efficiency class		A	A	A
For boiler space heaters and boiler combination heaters: Useful efficiency				
At rated heat output and high-temperature regime (*) η_4	%	87,5	87,2	88,3
At 30 % of rated heat output and low-temperature regime (**) η_1	%	97,0	97,0	97,8
For cogeneration space heaters: Useful efficiency				
At rated heat output of cogeneration space heater with supplementary heater disabled	%	-	-	-
$\eta_{CHP100+Sup0}$				
At rated heat output of cogeneration space heater with supplementary heater enabled	%	-	-	-
$\eta_{CHP100+Sup100}$				
Supplementary heater				
Rated heat output P _{sup}	kW	-	-	-
Type of energy input		-	-	-
Other items				
Standby heat loss P _{stby}	kW	0,059	0,059	0,059

2. MAINTENANCE

Model		R2K 24	R2K 28	R2K 34
		Rain H	Rain	Rain
Ignition burner power consumption P_{ign}	kW	0,000	0,000	0,000
Emissions of nitrogen oxides NOx	m g / kWh	32	36	49
Annual energy consumption Q_{HE}	kWh / GJ	20513 / 73,85	24422 / 87,92	29444 / 106
Sound power level, indoors L_{WA}	dB	52	52	52
For combination heaters:				
D.H.W. energy efficiency class		A	A	A
Declared load profile		XL	XL	XL
Daily electricity consumption Q_{elec}	kWh	0,146	0,154	0,160
Water heating energy efficiency η_{wh}	%	86	87	87
Daily fuel consumption Q_{fuel}	kWh	23,929	23,660	26,821
Contact details	Tel. +39 0721 9079.1 - fax. +39 0721 9079299 - e-mail: info@radiant.it - http://www.radiant.it			
Name and address of the supplier	RADIANT BRUCIATORI S.p.A. Via Pantanelli, 164/166 - 61025 - Montelabbate (PU)			

(*) High-temperature regime means 60 °C return temperature at heater inlet and 80 °C feed temperature at heater outlet.

(**) Low temperature means for condensing boilers 30 °C, for low-temperature boilers 37 °C and for other heaters 50 °C return temperature (at heater inlet).

2.2.8. TECHNICAL ASSEMBLY

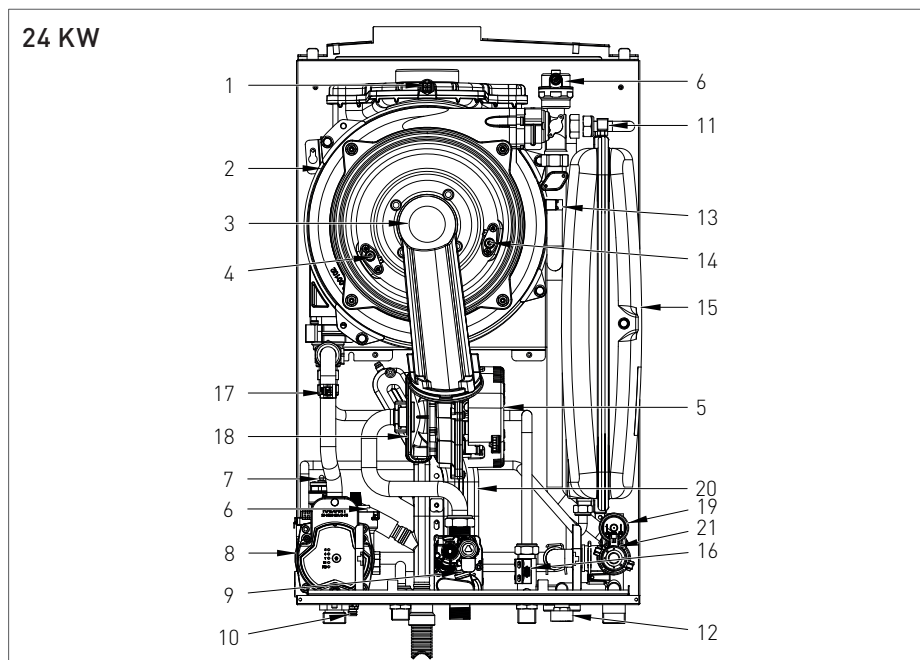

KEY

- | | |
|---|--|
| 1. FLUE SENSOR + FLUE SAFETY THERMO FUSE | 12. SYSTEM FILLING TAP |
| 2. CONDENSING HEAT EXCHANGER (PIPE IN PIPE) | 13. HEATING SENSOR + SAFETY THERMOSTAT |
| 3. BURNER | 14. IGNITION ELECTRODE |
| 4. FLAME DETECTION ELECTRODE | 15. EXPANSION VESSEL |
| 5. FAN | 16. FLOW SWITCH |
| 6. AIR VENT VALVE | 17. SYSTEM RETURN SENSOR |
| 7. 3 bar SAFETY VALVE | 18. VENTURI |
| 8. MODULATING PUMP | 19. WATER PRESSURE SWITCH |
| 9. GAS VALVE | 20. CONDENSATE SIPHON |
| 10. SYSTEM DRAINING TAP | 21. 3-WAY VALVE |
| 11. D.H.W. SENSOR | |

2. MAINTENANCE

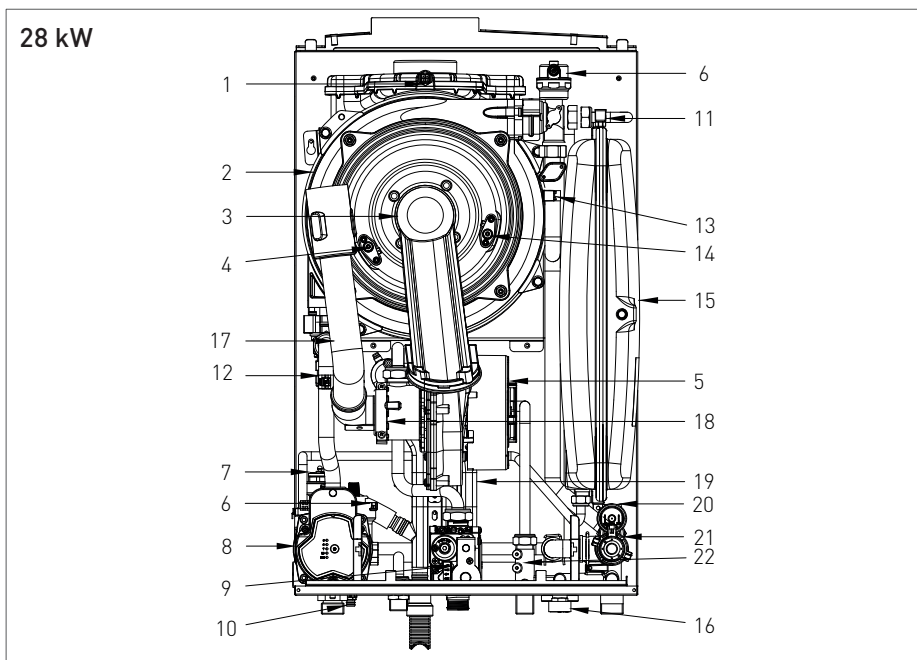

KEY

- | | |
|---|--|
| 1. FLUE SENSOR + FLUE SAFETY THERMO FUSE | 12. SYSTEM RETURN SENSOR |
| 2. CONDENSING HEAT EXCHANGER (PIPE IN PIPE) | 13. HEATING SENSOR + SAFETY THERMOSTAT |
| 3. BURNER | 14. IGNITION ELECTRODE |
| 4. FLAME DETECTION ELECTRODE | 15. EXPANSION VESSEL |
| 5. FAN | 16. SYSTEM FILLING TAP |
| 6. AIR VENT VALVE | 17. AIR INTAKE PIPE |
| 7. 3 bar SAFETY VALVE | 18. VENTURI |
| 8. MODULATING PUMP | 19. CONDENSATE Syphon |
| 9. GAS VALVE | 20. WATER PRESSURE SWITCH |
| 10. SYSTEM DRAINING TAP | 21. 3-WAY VALVE |
| 11. D.H.W. SENSOR | 22. FLOW SWITCH |

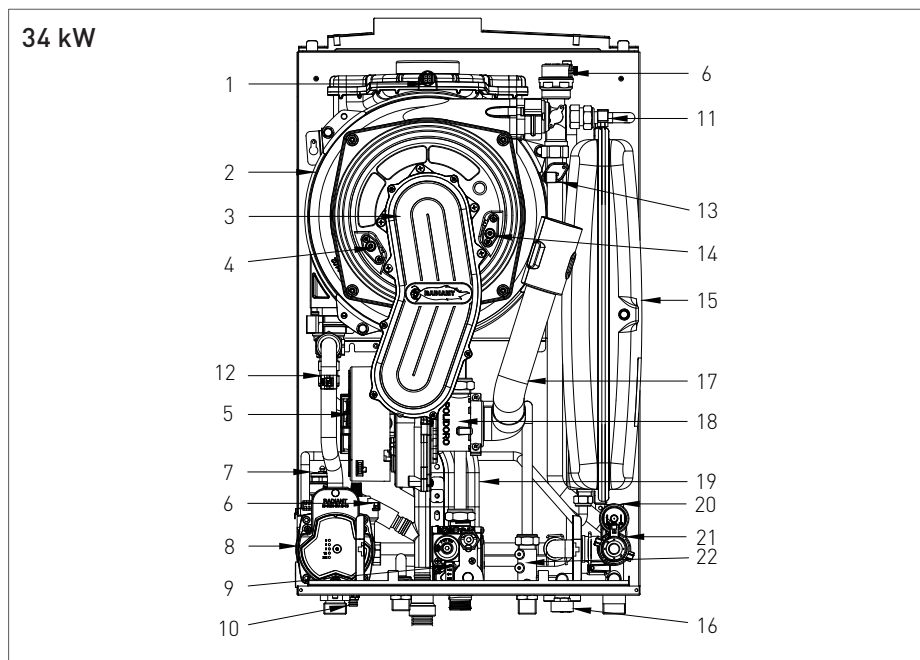

KEY

- | | |
|---|--|
| 1. FLUE SENSOR + FLUE SAFETY THERMO FUSE | 12. SYSTEM RETURN SENSOR |
| 2. CONDENSING HEAT EXCHANGER (PIPE IN PIPE) | 13. HEATING SENSOR + SAFETY THERMOSTAT |
| 3. BURNER | 14. IGNITION ELECTRODE |
| 4. FLAME DETECTION ELECTRODE | 15. EXPANSION VESSEL |
| 5. FAN | 16. SYSTEM FILLING TAP |
| 6. AIR VENT VALVE | 17. AIR INTAKE PIPE |
| 7. 3 bar SAFETY VALVE | 18. VENTURI |
| 8. MODULATING PUMP | 19. CONDENSATE Syphon |
| 9. GAS VALVE | 20. WATER PRESSURE SWITCH |
| 10. SYSTEM DRAINING TAP | 21. 3-WAY VALVE |
| 11. D.H.W. SENSOR | 22. FLOW SWITCH |

2. MAINTENANCE

2.2.9. HYDRAULIC DIAGRAM

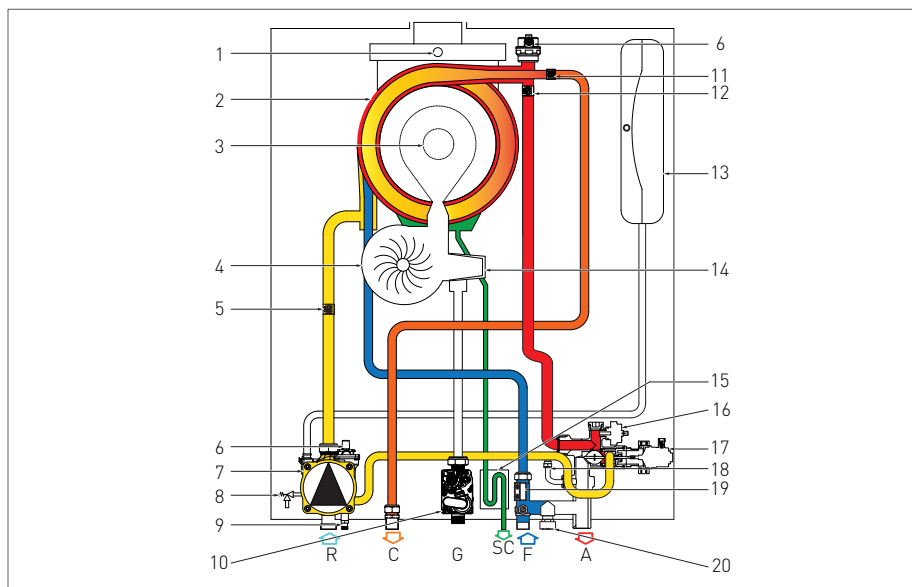

KEY

R. HEATING RETURN

C. D.H.W. OUTLET

G. GAS

SC. CONDENSATE DRAIN

F. COLD WATER INLET

A. HEATING FLOW

1. FLUE SENSOR + FLUE SAFETY
THERMO FUSE

2. CONDENSING HEAT
EXCHANGER (Pipe in Pipe)

3. BURNER

4. FAN

5. BY-PASS

6. AIR VENT VALVE

7. PUMP

8. 3 bar SAFETY VALVE

9. SYSTEM DRAINING TAP

10. GAS VALVE

11. D.H.W. SENSOR

12. SYSTEM RETURN SENSOR

13. HEATING SENSOR + SAFETY
THERMOSTAT

14. EXPANSION VESSEL

15. SYSTEM FILLING TAP

16. VENTURI

17. CONDENSATE SIPHON

18. 3-WAY VALVE

19. FLOW SWITCH

20. WATER PRESSURE SWITCH

2. MAINTENANCE

2.2.10. WIRING DIAGRAM

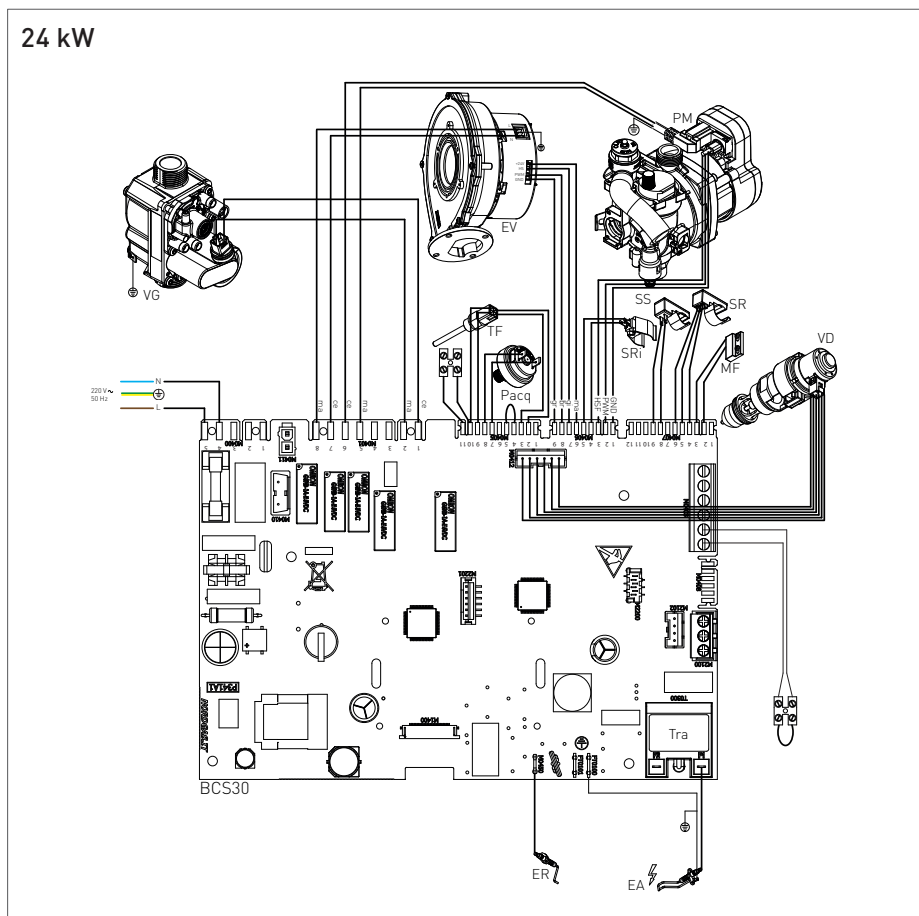

EA: IGNITION ELECTRODE	TF: FLUE SENSOR + FLUE SAFETY THERMO FUSE (102°C)	L: LIVE / PHASE	BI: WHITE
ER: ELETTRODO RIVELAZIONE	SS: D.H.W. SENSOR	N: NEUTRAL	GR: GREY
TRA: IGNITION TRANSFORMER	SR: HEATING SENSOR + SAFETY THERMOSTAT	NE: BLACK	
VG: GAS VALVE		CE: BLUE	
EV: FAN	PM: MODULATING PUMP	MA: BROWN	
PACQ: WATER PRESSURE SWITCH	MF: FLOW SWITCH MICRO	AR: ORANGE	
SRI: RETURN SENSOR	VD: 3-WAY VALVE	GI: YELLOW	

SERVICE CENTRE

2. MAINTENANCE

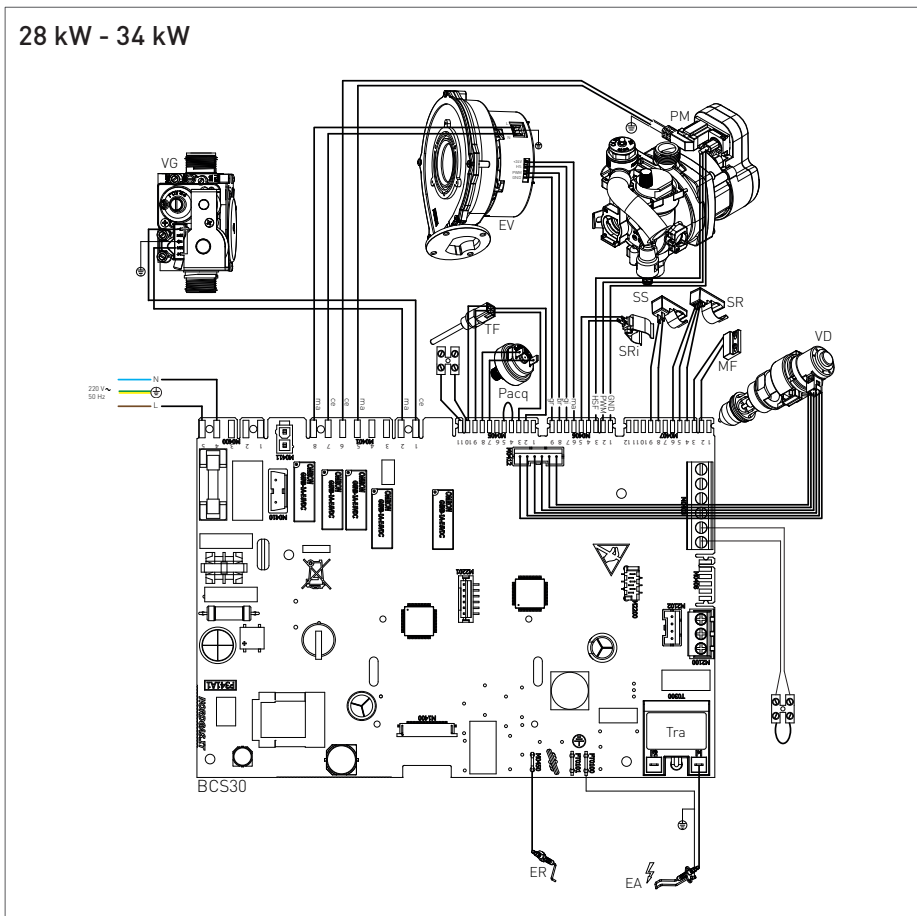

- | | | | |
|-----------------------------|---|-----------------|-----------|
| EA: IGNITION ELECTRODE | TF: FLUE SENSOR + FLUE SAFETY THERMO FUSE (102°C) | L: LIVE / PHASE | BI: WHITE |
| ER: ELETTRODO RIVELAZIONE | SS: D.H.W. SENSOR | N: NEUTRAL | GR. GREY |
| TRA: IGNITION TRANSFORMER | SR: HEATING SENSOR + SAFETY THERMOSTAT | NE: BLACK | |
| VG: GAS VALVE | | CE: BLUE | |
| EV: FAN | PM: MODULATING PUMP | MA: BROWN | |
| PACQ: WATER PRESSURE SWITCH | MF: FLOW SWITCH MICRO | AR: ORANGE | |
| SRI: RETURN SENSOR | VD: 3-WAY VALVE | GI: YELLOW | |

2.2.11. ACCESSING THE BOILER

For most control and maintenance operations, the panels of the casing have to be removed.

To remove the panel of the boiler, please follow the instructions below (see fig.1):

- > remove the fastening screws (1) placed on the side of the panel flange and remove it;
- > remove the fastening screws (2) placed on the upper and lower side of the panel, and remove it by pulling it towards yourself;
- > remove the fastening screws (3) placed on the lower side of the boiler and remove the connection cover.

To intervene on the front of the boiler, please proceed as follows:

- > remove the fastening screws (4) placed on the front panel;
- > grab the front panel and remove it by pulling it towards yourself;

To intervene on the side panels of the boiler, please proceed as follows:

- > remove the fastening screws (5) placed on the front edge of the side panel;
- > grab the bottom of the panel, and remove it by moving it sideways and pulling it upwards.

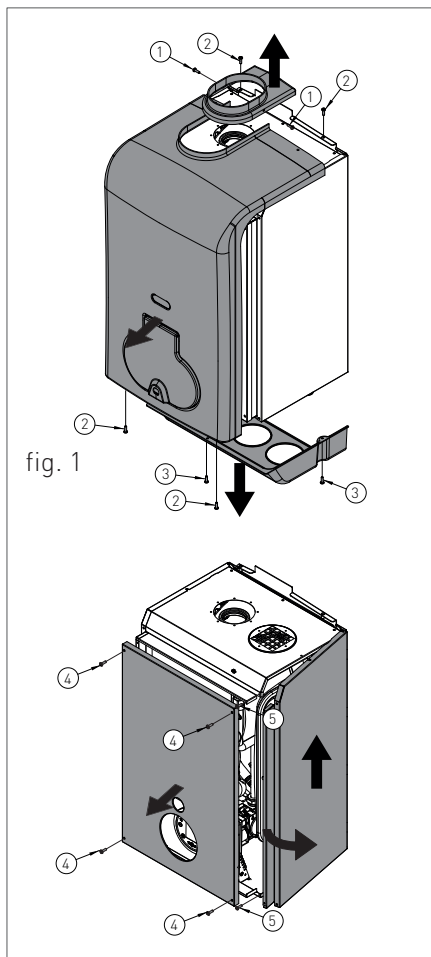

2.2.12. ACCESSING THE ELECTRONIC BOARD

In order to intervene on the wirings of the control panel, please proceed as follows:



DANGER

Cut off the voltage from the main switch.

- › Grab at the same time the support brackets of the control panel (fig. 1) loosening them and turn the panel downwards;
- › unscrew the two fastening screws 1 - fig. 1;
- › disengage the four hooks '2' - fig. 1;
- › remove the crankcase pulling it upwards.

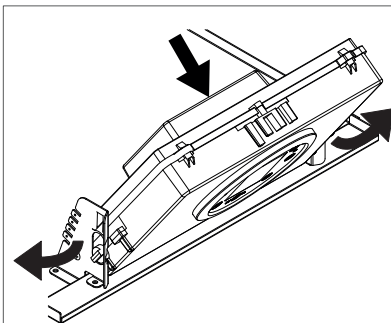
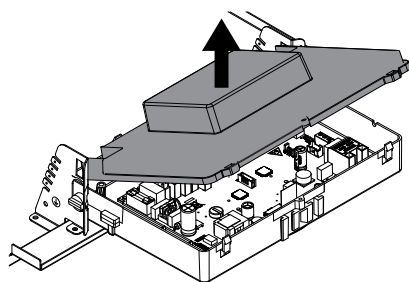
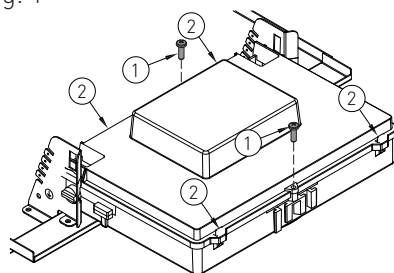

fig. 1



2.2.13. SYSTEM EMPTYING

HEATING SYSTEM EMPTYING

Whenever you need to empty the system, proceed as follows:

- › switch the boiler to “WINTER” mode and activate it;
- › turn off the main power supply switch;
- › wait for the boiler to cool down;
- › connect a flexible tube to the system emptying outlet and connect the other end of the tube to a suitable discharge;
- › turn the discharge tap of the system ‘RS’ (fig. 1);
- › open the relief valves of the radiators starting from the one at the top and continuing downwards;
- › after draining out all water, close the relief valves of the radiators and the emptying tap.

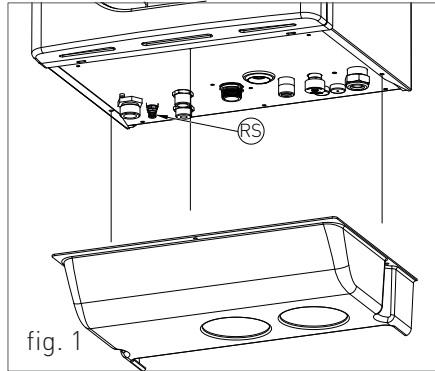

EMPTYING THE DOMESTIC SYSTEM

If there is freezing risk, you have to empty the domestic system as follows:

- › close the main supply tap of the water supply network;
- › open all cold and hot water taps;
- › after completing all operations, close the discharge tap and all previously opened water taps.

2.2.14. GAS CONVERSION (24 kW)



ATTENTION

Make sure that the gas adduction tube is suitable for the new type of fuel with which the boiler is supplied.

- › Unscrew the tube coupling that connects the gas valve to venturi.
- 1. Unscrew the tube coupling that connects the gas valve to venturi.

CONVERSION TO LPG:

- 2. Insert the diaphragm '1' (for LPG – Ø 6 mm diaphragm - code 15-01728) and gaskets '2' and re-tighten the coupling '3' (see fig.1).

CONVERSION TO NATURAL GAS:

- 2. Remove the diaphragm '1' and re-tighten the coupling '3' (see fig.1).
- 3. Remount the components following the demounting operations in reverse (see fig.1);
- 4. use soapy water method to check for gas leaks each time gas connections are dismantled and reassembled;
- 5. set the boiler to operate with the new type of gas, changing the value of the parameter P02 'GAS TYPE SELECTION' from the control panel (see chapters 'PARAMETERS TABLE' and

'ACCESSING AND PROGRAMMING THE PARAMETERS');

- 6. adjust the CO₂ combustion value as indicated in chapter 'CO₂ VALUE CHECK AND CALIBRATION'.

IN THE CASE OF CONVERSION TO PROPANE GAS (G230):

- › Follow steps 1 to 4 described for conversion to natural gas.
- 5. Set the boiler to operate with the new type of gas by changing the value to "0" (methane) for parameter P02 "GAS TYPE SELECTION" from the control panel (see chapters "PARAMETER TABLE" and "PARAMETER ACCESS AND PROGRAMMING").
- 6. adjust the CO₂ combustion value as indicated in chapter 'CO₂ VALUE CHECK AND CALIBRATION'.

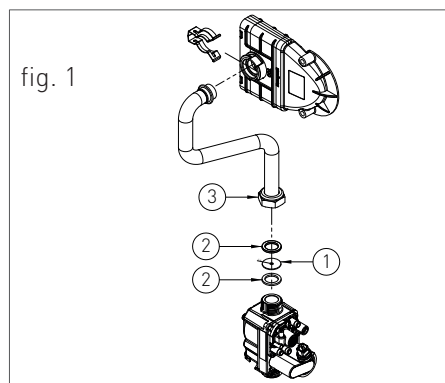

2.2.15. GAS CONVERSION (28 kW / 34 kW)



ATTENTION

Make sure that the gas adduction tube is suitable for the new type of fuel with which the boiler is supplied.

- › loosen the two screws '1' (fig.1) from the fastening bush, and remove the air suction tube;
- › unscrew the tube coupling that connects the gas valve to venturi;
- › unscrew the three fastening screws '2' (fig.1) of the venturi 'V' (fig.1) using a 10 key, as shown in figure 2;
- › remove the two screws '3' (fig.3) and apply pressure on the rear side of venturi 'C' (fig.3);
- › replace the body venturi with the one suitable for the type of supply gas (28 kW - cod. 30-00232 for Natural gas / cod. 30-00499 for Universal LPG / cod. 30-00167 for propaned air) (34 kW - cod. 30-00207 for Natural gas / cod. 30-00499 for Universal LPG / cod. 30-00199 for propaned air) and make sure the tooth 'D' (fig.3) is adjusted downwards on the aluminium ring nut (see fig.3);

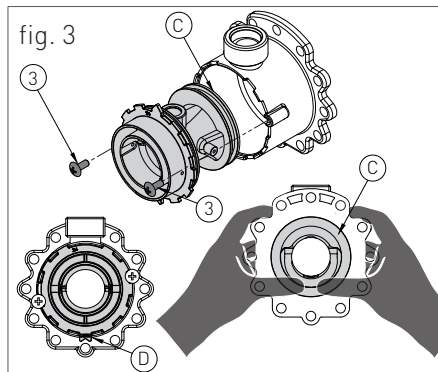
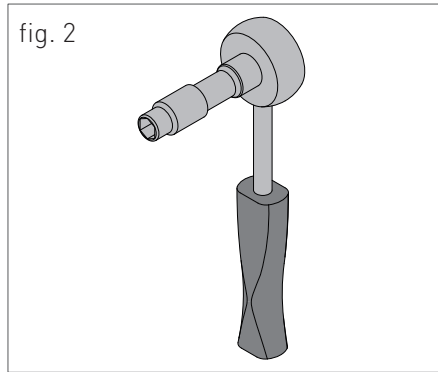
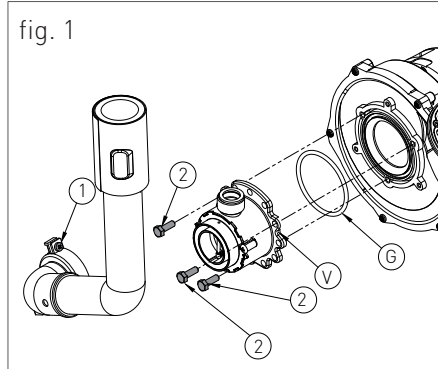

2. MAINTENANCE

- › remount the components following the demounting operations in reverse making sure that gasket 'G' is re-assembled as shown in fig.1;
- › set the boiler to operate with the new type of gas, changing the value of the parameter P02 'GAS TYPE SELECTION' from the control panel (see chapters 'PARAMETERS TABLE' and 'ACCESSING AND PROGRAMMING THE PARAMETERS');
- › adjust the CO₂ combustion value as indicated in chapter 'CO₂ VALUE CHECK AND CALIBRATION'.

3. USER SECTION

The operations described in this section are addressed to all those who will use the machine. The machine must be used and accessed only by qualified operators that fully read and understood the User section, paying particular attention to the warnings.

3.1. USE

3.1.1. GENERAL USE WARNINGS



WARNING

Before starting the boiler the User must make sure that the First start-up certificate has the stamp of the technical Support Centre proving the testing and the first start-up of the boiler.



WARNING

In order to take advantage of the guarantee provided by the manufacturer, the customer should carefully and exclusively observe the instructions given in the USER section of the manual.



ATTENTION

This machine may be used only for the purpose for which it has been designed: heat water to a temperature below boiling point at atmospheric pressure. Any other use is considered wrong and dangerous. The manufacturer is excluded from any contractual or out of contract responsibility for damage caused to people, animals or property due to incorrect use.



DANGER

The boiler should not be used by persons (including children) with reduced physical, sensory or mental capacities or without suitable knowledge or experience unless they are instructed on the device use or monitored by a person responsible for their safety.



DANGER

DO NOT obstruct the air vents of the location in which the gas device is installed to prevent the formation of toxic explosive mixes.



DANGER

If you sense a gas odour in the location in which the boiler is installed, proceed as follows:

- > DO NOT use electrical switches, the telephone or any other device that might generate electrical discharges or sparks;
- > Immediately open all doors and windows to create an air exchange that can quickly clean the location;
- > Close the gas valves;
- > Request immediate intervention of qualified staff.



DANGER

The use of the electrical power boiler implies respecting some fundamental rules such as:

- › DO NOT touch the device with wet and/or humid parts and/or with bare feet;
- › DO NOT pull the electrical cables;
- › DO NOT leave the device exposed to atmospheric agents (rain, sun, etc.) unless specifically intended;
- › in case of cable damage, turn off the device and contact qualified professional staff to replace it.

3. USE

3.1.2. CONTROL PANEL

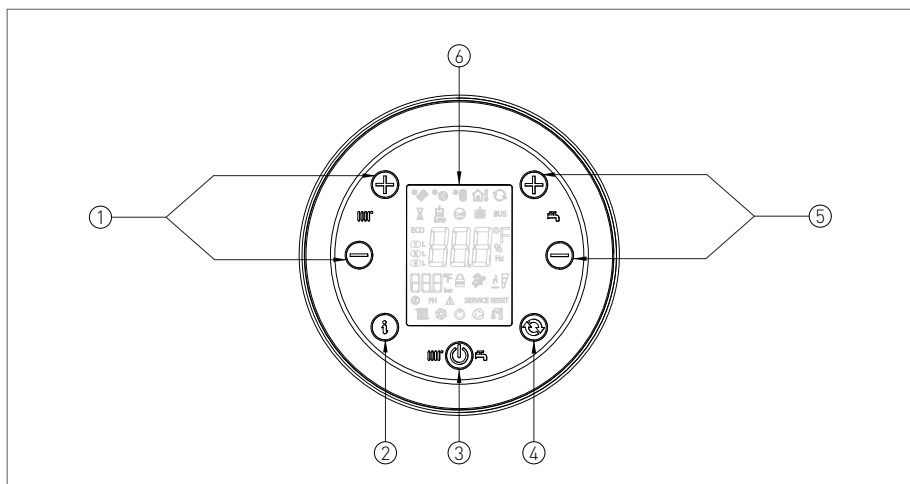

KEY

1. HEATING TEMPERATURE ADJUSTMENT KEYS
2. INFO KEY: PRESS ONCE TO DISPLAY TEMPERATURES AND OTHER INFORMATION (see chapter 'INFO MENU DISPLAY') - PRESS AND HOLD FOR 5 SECONDS, IN OFF MODE, TO DISPLAY THE LAST 5 FAULTS
3. OPERATING MODE SELECTION KEY: SUMMER / ONLY HEATING / WINTER / OFF
4. RESET KEY: FAULTS RESET - CHIMNEY SWEEP FUNCTION ACTIVATION (PRESS AND HOLD FOR 7 SECONDS)
5. DOMESTIC HOT WATER TEMPERATURE ADJUSTMENT

- KEY / PRESS THE KEYS SIMULTANEOUSLY FOR 5 SECONDS TO ACTIVATE THE DISPLAY BACKLIGHTING FOR 10 MINUTES
6. DISPLAY

3. USE

3.1.3. DISPLAY ICONS

KEY

1. MENU INFO DISPLAY
2. DISPLAY OF PARAMETER NUMBER OR INFO CODE OR AUXILIARY TEMPERATURE (IF ACTIVATED THROUGH PARAMETER P42)
3. HIGH AND LOW TEMPERATURE ZONES ENABLED
4. PARAMETER PROGRAMMING LOCK ENABLED
5. ECO FUNCTION ENABLED
6. WAITING TIME BETWEEN BURNER IGNITIONS
7. LACK OF WATER IN THE SYSTEM / INSUFFICIENT WATER PRESSURE
8. CONNECTED SOLAR P.C.B. SIGNALLING / SOLAR COLLECTOR TEMPERATURE DISPLAY (d5)
9. ACTIVE SOLAR PUMP
10. DHW TANK LOWER TEMPERATURE DISPLAY (d6) / DHW TANK UPPER TEMPERATURE DISPLAY (d7)
11. MIXING VALVE ENABLED
12. OUTDOOR SENSOR INSTALLED / OUTDOOR TEMPERATURE SENSOR (d1)

13. OPENTHERMCOMMUNICATION PRESENT (REMOTE CONTROL / ZONES CONTROLLER)
14. LOW TEMPERATURE ENABLED
15. ACTIVE MODBUS

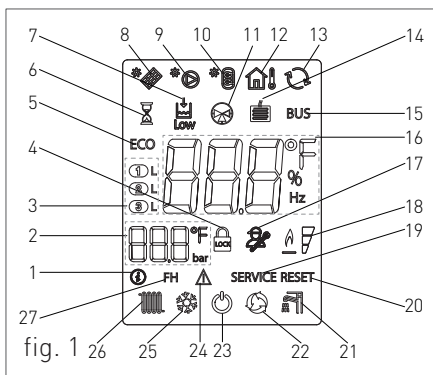

fig. 1

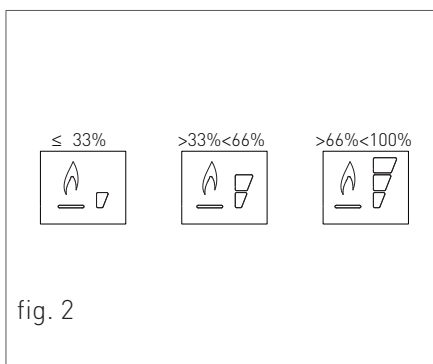

fig. 2

16. TEMPERATURE DISPLAY / SET POINT / PARAMETER VALUE
17. PARAMETERS PROGRAMMING FUNCTION ACTIVE
18. FLAME PRESENCE SIGNALLING / IT ALSO INDICATES, ON 3 PERCENTAGE





USER

3. USE







LEVELS, THE DEGREE OF
BOILER MODULATING POWER
(fig.2)

19. NON-RESETTABLE ERROR
DISPLAY, REQUIRING
TECHNICAL SERVICE
20. RESETTABLE ERROR DISPLAY
21. D.H.W. MODE ENABLED
22. RECIRCULATION FUNCTION
ENABLED/ IF FLASHING, THE
FUNCTION IS ACTIVE
23. OFF OPERATING MODE
24. WARNING INFORMATION
25. COOLING MODE ENABLED
26. HEATING MODE ENABLED
27. FAST H2O FUNCTION ENABLED

3.1.4. INFO MENU DISPLAY DATA

To view the boiler data from info menu you just have to press the INFO  key. The info code will be displayed on the left side of the screen and its relative value will be displayed on the centre of the screen. Use keys  and  of the heating circuit  to scroll through the list of displayed data. To exit display mode press the INFO  key.

LIST OF DISPLAYED DATA

INFO CODE	ICON	DESCRIPTION
d0		DOMESTIC CIRCUIT PROBE TEMPERATURE
d1		EXTERNAL PROBE TEMPERATURE
d2		FAN SPEED
d3		BOTTOM AREA PROBE TEMPERATURE [IF AREA BOARD INSTALLED]
d4		RETURN PROBE TEMPERATURE
d5		SOLAR COLLECTOR TEMPERATURE [IF SOLAR BOARD INSTALLED] (SCS)
d6		SOLAR BOILER TEMPERATURE (BOTTOM) [IF SOLAR BOARD INSTALLED] (SBSI)
d7		SOLAR BOILER TEMPERATURE (TOP) [IF SOLAR BOARD INSTALLED] (SBSS)
d8		SOLAR COLLECTOR PROBE TEMPERATURE 2 [IF SOLAR BOARD INSTALLED] (SCS2)

3. USE

INFO CODE	ICON	DESCRIPTION
d9		EXTRASOLAR BOILER TEMPERATURE (IF SOLAR BOARD INSTALLED) (SBS3)
d10		SETPOINT CALCULATED BY CLIMATE CONTROL
d11		CURRENT PERCENTAGE OF BURNER POWER
d12		HEATING FLOW RATE DISPLAY EXPRESSED IN L/MIN (IF THERE IS A FLOWMETER).
d13		LOW-TEMPERATURE HEATING CIRCUIT RETURN SENSOR TEMPERATURE (IN HYBRID SYSTEM BOX MODE) - HEATING PUMP RETURN SENSOR TEMPERATURE (IN HYBRID DOMESTIC SYSTEM MODE)
d14		INERTIAL STORAGE SENSOR TEMPERATURE
d15		HYBRID SYSTEM BOX D.H.W. TANK SENSOR TEMPERATURE - HOT WATER TEMPERATURE OUT OF THE REMOTE TANK TO THE BOILER (ONLY FOR HYBRID DOMESTIC SYSTEM WITH OPTIONAL SENSOR)
d16		POWER SUPPLIED BY THE HEATING PUMP IN KW/H (ONLY FOR HYBRID DOMESTIC SYSTEM)
d17		FLUE EXHAUST TEMPERATURE
d18		DHW OUTLET SENSOR TEMPERATURE FROM MIXING VALVE

3. USE

INFO CODE	ICON	DESCRIPTION
d19		MIXING VALVE OPENING STATUS DISPLAY (OP = COLD WATER INLET WHILE IN OPENING POSITION; CO = COLD WATER INLET WHILE IN CLOSING POSITION)
d20		INLET DHW TEMPERATURE (°C) - (SIS)
d21		0 - 10 VOLTS SIGNAL READING
d22		REMAINING DAYS FROM SCHEDULED ANNUAL MAINTENANCE
d23		/
d24		/
d25		/
d26		/
d27		/
d28		/
d29		LCD FIRMWARE VERSION
d30		SECURITY FIRMWARE VERSION

3.1.5. START-UP



Before starting the boiler make sure that it is powered and that the gas tap below the boiler is open.

To start the boiler press the function key  and select the desired operating mode. If the symbol is displayed fixed, it means that the function was activated.

3.1.6. OPERATING MODE

SUMMER MODE



In this mode the boiler meets only the demands of domestic hot water.

To switch the boiler to SUMMER operating mode, press the function key , the symbol  will appear fixed on the display, indicating that the function is enabled.

Whenever hot domestic water is needed the automatic start-up system will start the burner; this is indicated by displaying the symbol  blinking.

ONLY HEATING MODE

In this mode the boiler meets only the demands of heating.



To switch the boiler to ONLY HEATING operating mode, press the function key , the symbol  will



appear fixed on the display, indicating that the function is enabled.

Whenever heating energy is needed to heat the rooms the automatic start-up system will start the burner; this is indicated by displaying the symbol  blinking.



WINTER MODE



In this mode the boiler meets the demands of heating and of domestic hot water.

To switch the boiler to WINTER operating mode, press the function key , the symbols  and  will appear fixed on the display, indicating that the function is enabled.

Whenever heating energy and domestic hot water are needed the automatic start-up system will start the burner; this is indicated by displaying the symbol  and  blinking.



ADJUSTING THE HEATING TEMPERATURE



You can adjust the temperature using keys  and  of the heating circuit :

- press key  to decrease the temperature.
- press key  to increase the temperature.

The heating temperature adjustment field ranges from 30 °C to 80 °C (25 °C – 45 °C for floor systems).

DOMESTIC HOT WATER TEMPERATURE ADJUSTMENT



You can adjust the temperature using keys  and  of the domestic circuit :

- press key  to decrease the temperature.
- press key  to increase the temperature.

The hot domestic water temperature adjustment field ranges from 35 °C to 60 °C.

OFF MODE

In this mode the boiler no longer meets the heating and domestic hot water demands, the anti-freeze, pump anti-locking and diverter valve anti-locking systems still remain active.

To switch the boiler to OFF operating mode, press the function key , the symbol  will appear fixed on the display, indicating that the function is enabled (for non condensing models will appear the message 'OFF').

If the boiler was previously running, it will be turned off and the post-

ventilation and post-circulation functions will be enabled.

If you have to deactivate the boiler for a long period of time, proceed as follows:

- > contact the Technical support centre that will empty the water system, where no anti-freeze is intended, and will cut off the power, water and gas supply.
- > Or leave the boiler in OFF operating mode keeping active the electrical and gas supplies so that the anti-freeze function may activate.

3.1.7. INFORMATIONAL NOTE ON ANTI- FREEZE FUNCTION

The boiler is protected against freezing thanks to the electronic board preparation with functions that start the burner and heat the concerned parts when their temperature goes below the minimum pre-set values.



WARNING

This function is available

only if:

- > the boiler is powered;
- > the gas supply is open;
- > the pressure of the system is proper;
- > the boiler is not blocked.

3. USE

3.1.8. SYSTEM FILLING

To restore the water pressure inside the system open the loading tap "R" (fig. 1) and make sure using pressure gauge "M" (fig. 1), that the system pressure reaches 1.2 bar (see fig. 2). After performing this operation, make sure that the loading tap "R" (fig. 1) is properly closed.

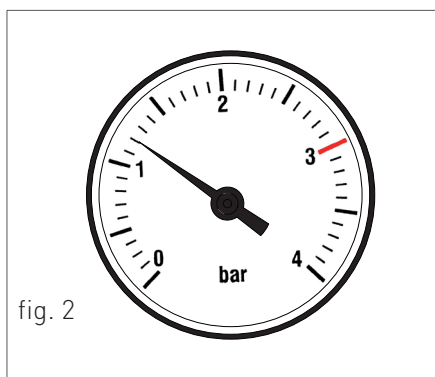
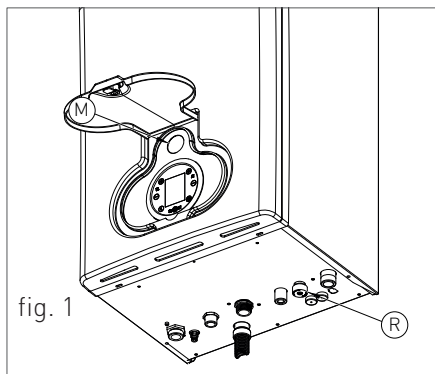

After the water pressure reset the boiler will automatically perform a 2 minutes system relief cycle. Throughout this function the display will show the code "F33". The boiler can work normally only after completing the operation.



3. USE

3.1.9. FAULT SIGNALLING CODES

The boiler might signal some faults by displaying a code. Below you have a list of the codes and of the operations to be performed in order to unlock the boiler.

CODE	ICON	FAULT	INTERVENTION
E01	RESET	FLAME BLOCK	<p>MAKE SURE THAT THE BOILER AND CONTACTOR GAS VALVES ARE OPEN.</p> <p>PRESS THE RESET  BUTTON ON THE CONTROL PANEL TO RESET THE FAULT, AS SOON AS THE ERROR CODE DISAPPEARS FROM THE DISPLAY, THE BOILER WILL START AUTOMATICALLY.</p> <p>IF THE BLOCK PERSISTS CONTACT THE TECHNICAL SUPPORT CENTRE.</p>
E02	RESET	SAFETY THERMOSTAT (95 °C)	<p>CONTACT THE TECHNICAL SUPPORT CENTRE.</p>
E03	RESET	FUMES SAFETY THERMOFUSE (102 °C)	<p>CONTACT THE TECHNICAL SUPPORT CENTRE.</p>
E04	 RESET	WATER MISSING IN THE SYSTEM	<p>IF THE SYSTEM PRESSURE IS BELOW 1.2 BAR, FILL THE SYSTEM AS DESCRIBED IN CHAPTER "SYSTEM FILLING".</p> <p>IF THE BLOCK PERSISTS CONTACT THE TECHNICAL SUPPORT CENTRE.</p>

3. USE

CODE	ICON	FAULT	INTERVENTION
E05	SERVICE	HEATING PROBE	CONTACT THE TECHNICAL SUPPORT CENTRE.
E06	SERVICE	DOMESTIC CIRCUIT PROBE	CONTACT THE TECHNICAL SUPPORT CENTRE.
E10	SERVICE	LOW FLOW RATE	CONTACT THE TECHNICAL SUPPORT CENTRE.
E14	SERVICE	AIR PRESSURE SWITCH	CONTACT THE TECHNICAL SUPPORT CENTRE.
E15	SERVICE	RETURN PROBE	CONTACT THE TECHNICAL SUPPORT CENTRE.
E16	SERVICE	ELECTRIC FAN	CONTACT THE TECHNICAL SUPPORT CENTRE.
E18	SERVICE	INSUFFICIENT CIRCULATION	CONTACT THE TECHNICAL SUPPORT CENTRE.
E22	SERVICE	PARAMETERS PROGRAMMING REQUEST	CUT OFF THE POWER SUPPLY FROM THE MAIN SWITCH AND THEN RESTORE IT, AS SOON AS THE ERROR CODE DISAPPEARS, THE BOILER WILL RESTART AUTOMATICALLY. IF THE BLOCK PERSISTS CONTACT THE TECHNICAL SUPPORT CENTRE.

3. USE

CODE	ICON	FAULT	INTERVENTION
E24	SERVICE	SOLAR PANEL SENSOR - PT1000- (SCS)	CONTACT THE TECHNICAL SUPPORT CENTRE.
E25	SERVICE	UPPER SOLAR TANK SENSOR (SBSS)	CONTACT THE TECHNICAL SUPPORT CENTRE.
E26	SERVICE	LOWER SOLAR TANK SENSOR (SBSS)	CONTACT THE TECHNICAL SUPPORT CENTRE.
E27	SERVICE	SOLAR PANEL NO.2 SENSOR - PT1000- (SCSS)	CONTACT THE TECHNICAL SUPPORT CENTRE.
E29	SERVICE	OPTIONAL SOLAR TANK SENSOR - NTC - (SBS3)	CONTACT THE TECHNICAL SUPPORT CENTRE.
E31	SERVICE	INCOMPATIBLE CONTROL REMOTE	CONTACT THE TECHNICAL SUPPORT CENTRE.
E35	RESET	RESIDUAL FLAME	PRESS THE RESET  BUTTON ON THE CONTROL PANEL TO RESET THE FAULT, AS SOON AS THE ERROR CODE DISAPPEARS FROM THE DISPLAY, THE BOILER WILL START AUTOMATICALLY.
E44	SERVICE	FLUE TEMPERATURE LIMIT SENSOR ERROR	CONTACT THE TECHNICAL SUPPORT CENTRE.
E45	SERVICE	FLUE TEMPERATURE LIMIT SENSOR ERROR / CABLE NOT DETECTED	CONTACT THE TECHNICAL SUPPORT CENTRE.







3. USE

CODE	ICON	FAULT	INTERVENTION
E49	RESET	HEATING FLOW SENSORS ERROR	CONTACT THE TECHNICAL SUPPORT CENTRE.
E50	RESET	HEATING FLOW SENSORS INTEGRITY	CONTACT THE TECHNICAL SUPPORT CENTRE.
E52	SERVICE	COMMUNICATION TIME-OUT ERROR BETWEEN BOILER AND CASCADE CONTROL UNIT (CASCADE SYSTEMS)	CONTACT THE TECHNICAL SUPPORT CENTRE.
E57	SERVICE	COMMUNICATION ERROR OF INTERNAL MICROCONTROLLERS	CONTACT THE TECHNICAL SUPPORT CENTRE.
E79	SERVICE	SHINOO PUMP CONNECTION FEEDBACK ERROR	CONTACT THE TECHNICAL SUPPORT CENTRE.
E80	SERVICE	WILO PUMP CONNECTION FEEDBACK ERROR	CONTACT THE TECHNICAL SUPPORT CENTRE.
E81	SERVICE	WILO PUMP MALFUNCTION	CONTACT THE TECHNICAL SUPPORT CENTRE.
E82	SERVICE	WILO PUMP MALFUNCTION IN MODE 1	CONTACT THE TECHNICAL SUPPORT CENTRE.
E83	SERVICE	WILO PUMP MALFUNCTION IN MODE 2	CONTACT THE TECHNICAL SUPPORT CENTRE.

3. USE

CODE	ICON	FAULT	INTERVENTION
E84	SERVICE	WILO PUMP PERMANENT FAILURE	CONTACT THE TECHNICAL SUPPORT CENTRE.
E85	SERVICE	SHINOO PUMP STUCK	CONTACT THE TECHNICAL SUPPORT CENTRE.
E86	SERVICE	SHINOO PUMP MALFUNCTION	CONTACT THE TECHNICAL SUPPORT CENTRE.
E88	SERVICE	COMMUNICATION ERROR BETWEEN MIXING VALVE BOARD AND BOILER BOARD	CONTACT THE TECHNICAL SUPPORT CENTRE.
E96	SERVICE	SHINOO PUMP ALARM	CONTACT THE TECHNICAL SUPPORT CENTRE.
E97	SERVICE	OT COMMUNICATION ERROR WITH EXTERNAL RELAYS	CONTACT THE TECHNICAL SUPPORT CENTRE.
E98	SERVICE	SUPPLY VOLTAGE	CONTACT THE TECHNICAL SUPPORT CENTRE.
E99	SERVICE	ELECTRIC LEAKAGE ON THE HIGH CIRCUIT VOLTAGE / ELECTRICAL NOISE DUE TO SPARK DISCHARGE	CUT OFF THE POWER SUPPLY FROM THE MAIN SWITCH AND THEN RESTORE IT, AS SOON AS THE ERROR CODE DISAPPEARS, THE BOILER WILL RESTART AUTOMATICALLY. IF THE BLOCK PERSISTS CONTACT THE TECHNICAL SUPPORT CENTRE.

3.1.10. ACTIVE FUNCTIONS SIGNALLING CODES

CODE	FUNCTION	INTERVENTION
ECO	ECO FUNCTION ACTIVE	YOU CAN ACTIVATE/DEACTIVATED IT BY HOLDING SIMULTANEOUSLY AND FOR 7 SECONDS THE KEYS  OF THE DOMESTIC CIRCUIT  AND  OF THE HEATING CIRCUIT  .
EH	DISPLAY OF ACHIEVEMENT OF THE MAXIMUM SET FLUE GAS TEMPERATURE. ACTIVATED AS STANDARD.	WAIT UNTIL THE OPERATION IS COMPLETED
F08	HEATING ANTI-FREEZE FUNCTION ACTIVE	WAIT UNTIL THE OPERATION IS COMPLETED
F09	D.H.W CIRCUIT ANTI-FREEZE FUNCTION ACTIVE	WAIT UNTIL THE OPERATION IS COMPLETED
F28	LEGIONELLA PREVENTION SYSTEM	WAIT UNTIL THE OPERATION IS COMPLETED
F33	SYSTEM AIR RELEASE CYCLE IN PROGRESS	WAIT UNTIL THE OPERATION IS COMPLETED
FH	FAST H2O	YOU CAN ACTIVATE/DEACTIVATED IT BY HOLDING SIMULTANEOUSLY AND FOR 7 SECONDS THE RESET  AND  OF THE DOMESTIC CIRCUIT  .
SCM	ACTIVE SCREED HEATING	WAIT UNTIL THE OPERATION IS COMPLETED

3.1.11. ECO FUNCTION

This function is useful for reducing consumption, allowing fixed economy of heating and DHW temperatures.

Once the function is enabled, the maximum DHW settable temperature will be 42°C, while the maximum Heating settable temperature will be: 60°C in case of a high temperature system or 32°C in case of a low temperature system.

To activate or deactivate the ECO function, follow the instructions at the chapter 'ACTIVE FUNCTIONS SIGNALLING CODES'.

3.1.12. FAST H2O FUNCTION

The Fast H2O function keeps a constant temperature in the DHW circuit within the boiler, according to the temperature set by the user.

The Fast H2O function offers three advantages:

- › the hot water is immediately supplied at the requested temperature.
- › unnecessary delays are avoided by increasing the comfort of the final user.
- › water wastes are limited waiting that the water reaches the right temperature.

To activate/deactivate the Fast H2O function please follow the instruction indicated in the paragraph 'ACTIVE FUNCTIONS SIGNALLING CODES'.

3.1.13. MAINTENANCE

To ensure proper boiler safety and efficiency, please contact RADIANT technical support network to check the device every year.

An accurate maintenance should improve system management.

indicates that this product can not be dismantled as domestic waste. Proper disposal of this product helps preventing potentially negative consequences for the environment and person's health.

3.1.14. EXTERNAL CASING CLEANING

Clean the cover of the device using a wet cloth and come neutral soap.



WARNING

DO NOT use abrasive or powder detergents as they might damage the plastic cover and control elements.

3.1.15. DISPOSAL

The boiler and all its accessories must be disposed of by differentiating them appropriately according to the recycling regulation in force.



The use of the symbol WEEE (Waste Electrical and Electronic Equipment)

