



Flexiheat UK
Heating and hot water solutions
www.flexiheatuk.com
01202 822221

Installation, Use and Maintenance Manual for model

RSP 34

Swimming pool condensing boiler / water heater

These swimming pool gas heaters are suitable for standard chlorinated pools and all wetted parts are made from 316 stainless steel. The pool water is directly heated within the boiler.

**There is no additional heat exchanger
required.**

SUMMARY

INTRODUCTION	4
--------------------	---

1. INSTALLER SECTION 7

1.1. INSTALLATION	8
1.1.1. GENERAL INSTALLATION WARNINGS	8
1.1.2. WATER HEATER LOCATION ENVIRONMENTAL REQUIREMENTS	8
1.1.3. REFERENCE LEGISLATION	9
1.1.4. UNPACKING	10
1.1.5. POSITIONING AND MINIMAL TECHNICAL SPACES	11
1.1.6. OVERALL DIMENSIONS	12
1.1.7. HYDRAULIC CONNECTIONS	12
1.1.8. HYDRAULIC CONNECTION	13
1.1.9. FILLING THE CONDENSATE COLLECTION SIPHON	14
1.1.10. FROST PROTECTION KIT	15
1.1.11. GAS CONNECTION	16
1.1.12. ELECTRICAL CONNECTION	16
1.1.13. OPTIONAL ELECTRICAL CONNECTIONS	17
1.1.14. FUME EXHAUST FITTINGS	18
1.1.15. TYPES OF FUME EXHAUST SYSTEMS	19

2. SUPPORT CENTER SECTION 23

2.1. FIRST START-UP	24
2.1.1. PRELIMINARY OPERATIONS FOR FIRST START-UP	24
2.1.2. WATER HEATER COMMISSIONING	25
2.1.3. CO2 VALUE CHECK AND CALIBRATION	26
2.1.4. ACCESSING AND PROGRAMMING THE PARAMETERS	27
2.1.5. MIAB3114 PARAMETERS TABLE	30
2.2. MAINTENANCE	32
2.2.6. GENERAL MAINTENANCE WARNINGS	32
2.2.7. TECHNICAL DATA	33
2.2.8. TECHNICAL ASSEMBLY	36
2.2.9. HYDRAULIC BOARD	37
2.2.10. WIRING DIAGRAM	38
2.2.11. ACCESSING THE WATER HEATER	39
2.2.12. ACCESSING THE ELECTRONIC BOARD	40
2.2.13. EMPTYING THE DOMESTIC SYSTEM	41
2.2.14. FAULT SIGNALLING CODES	42
2.2.15. ACTIVE FUNCTIONS SIGNALLING CODES	45
2.2.16. GAS TYPE TRANSFORMATION	46

3. USER SECTION

47

3.1. USE	48
3.1.1. GENERAL USE WARNINGS	48
3.1.2. CONTROL PANEL	49
3.1.3. DISPLAY ICONS	50
3.1.4. INFO MENU DISPLAY DATA	51
3.1.5. START-UP	52
3.1.6. DOMESTIC HOT WATER TEMPERATURE ADJUSTMENT	52
3.1.7. OFF MODE	52
3.1.8. INFORMATIONAL NOTE ON ANTI-FREEZE FUNCTION	52
3.1.9. FAULT SIGNALLING CODES	53
3.1.10. ACTIVE FUNCTIONS SIGNALLING CODES	54
3.1.11. MAINTENANCE	55
3.1.12. COVER CLEANING	55
3.1.13. DISPOSAL	55

INTRODUCTION

WARNING

Before starting any operation it is mandatory to read this instruction manual, in relation to the activities to be carried out as described in each relevant section. Proper operation and optimal performance of the water heater are ensured by strict compliance with all the instructions given in this manual.

The installation, use and maintenance manual is an integral and essential part of the product and must be delivered to the user.

MANUAL USERS

The manual users are all those who install, use and maintain the water heater.

The water heater must be used and accessed only by qualified operators that fully read and understood the use and maintenance manual, paying particular attention to the warnings.

READING AND SYMBOLS OF THE MANUAL

To ease the understanding of this manual, recurrent symbols where used, in particular:

- › On the outer margin of the page is placed a thumb index indicating the type of user to which the instructions in that section address.
- › The titles are differentiated by thickness and size in accordance with their hierarchy.
- › The images contain important parts described in the text, marked with numbers or letters.
- › (See chap. "chapter name"): this entry indicates another section in the Manual that you should refer to.

- › Device: this term is used referring to the water heater.



DANGER

It identifies an information related to a general danger that if not complied with, may cause serious personal damage or even death.



ATTENTION

It identifies an information that if not complied with may cause small or medium level lesions to the person or serious deterioration to the water heater.



WARNING

It identifies a precaution information that must be observed in order to avoid damaging the machine or parts of it.

MANUAL STORAGE

The manual must be carefully stored and replaced in case of deterioration and/or low legibility.

If you misplace the use and maintenance manual, you can request it from the Service Centre giving the serial number and model of the boiler indicated on the data plate placed on the right side of its casing.

MANUFACTURER WARRANTY AND RESPONSIBILITY

equipped with all accessories necessary to render it a veritable independent heating unit. All water heaters are tested and delivered with a quality certificate signed by the tester.

The technical and functional features of the device are ensured by its use in compliance:

1. with the use and maintenance instructions contained in the manuals accompanying the product, the content of which the customer certifies that he is aware;
2. with the conditions and purposes to which devices of the same type are intended.

For more information on the warranty validity, its duration, the obligations and the exemptions, please consult the First start-up certificate attached to this manual.

The manufacturer reserves:

- › the right to modify the tools and relative technical documentation without any obligation to third parties; neither will the company be held responsible for any inaccuracies in this handbook deriving from printing or translation errors;
- › the material and intellectual ownership of this manual and forbids its distribution and duplication, even partial, without prior written authorization.

PRODUCT CONFORMITY

The materials used such as copper, brass, stainless steel create a homogeneous, compact and functional assembly, easy to install and manage. In its simplicity, the water heater is

1. INSTALLER SECTION

The installation operations described in this section, must be performed only by qualified personnel, having the appropriate technical training in the field for the installation and maintenance of components of civil and industrial domestic hot water production and heating plants.

1.1. INSTALLATION

1.1.1. GENERAL INSTALLATION WARNINGS



ATTENTION

This water heater may be used only for the purpose for which it has been designed: heat water to a temperature below boiling point at atmospheric pressure. Any other use is considered wrong and dangerous. The manufacturer is excluded from any contractual or extra-contractual responsibility for damages caused to people, animals or property due to errors during installation.



ATTENTION

This water heater must be installed only by qualified personnel, having the appropriate technical training in the field for the installation and maintenance of components of civil and industrial domestic hot water production and heating plants.



ATTENTION

After having removed the packing, make sure the device is intact. In case of doubt, do not use the device and contact the supplier.

BEFORE INSTALLING THE WATER HEATER, THE INSTALLER MUST MAKE SURE THAT THE FOLLOWING CONDITIONS ARE MET:

- › The device is connected to a heating system and a water supply network appropriate for its power and performance.
- › The location must be properly vented through an air vent.
- › The air vent must be placed at floor level to prevent it from being obstructed, protected by a grid that does not hamper the useful passage section.

- › The device is suitable for use with the type of gas available by checking the water heater data plate (placed on the inner side of the front casing).
- › Make sure that the pipes and joints are perfectly sealed, without any gas leaks.
- › Make sure that the grounding system works properly.
- › Make sure that the electrical system is suitable for the maximum power absorbed by the device, value indicated on the data plate.

1.1.2. WATER HEATER LOCATION ENVIRONMENTAL REQUIREMENTS

The device installation location should be vented due to the presence of threaded joints on the gas supply line. The location should be therefore provided with vents as to ensure air exchange, with output grid in the natural accumulation area of potential gas losses.



WARNING

If the temperature in the appliance installation location goes below -10 centigrades, please fill the plant with anti-freeze liquid and insert and a frost prtotection kit (see chapter 'ANTI-FREEZE PROTECTION').



WARNING

The manufacturer will not be held responsible for damages caused by incorrect

installation not in conformity with the above mentioned instructions and not duly protected from freeze.

1.1.3. REFERENCE LEGISLATION

The installation must be done according to the requirements of current legislation and in compliance with local technical regulations, according to the indications of the good technique.

1. INSTALLATION

1.1.4. UNPACKING



WARNING

Please unpack the water heater just before installing it. The Company is not responsible for the damages caused to the device due to incorrect storage.



WARNING

The packing elements (cardboard box, wooden crate, nails, fasteners, plastic bags, expanded polystyrene, etc.) must be kept out of the reach of children as they may be dangerous. Therefore they should be dismantled suitably differentiating them in accordance with the standards in force.

To unpack the water heater, proceed as follows:

- > Place the packed water heater on the floor (fig. 1-A) and remove the fasteners opening the four flaps of the box outwards.
- > Turn the water heater at 90° holding it with your hand (fig. 1-B).
- > Lift the box (fig. 1-C) and remove the guards (fig. 1-D).

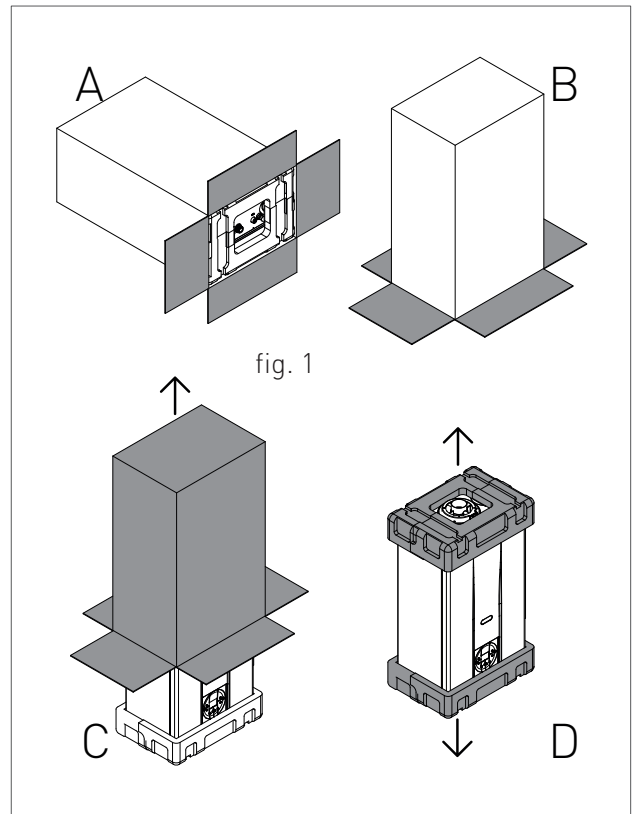

1.1.5. POSITIONING AND MINIMAL TECHNICAL SPACES

The water heater must be installed only on a vertical solid wall, able to sustain its weight.

In order to allow the access inside the water heater for maintenance operations, the minimum technical spaces indicated in figure 1 have to be respected.

To facilitate the installation, the water heater is provided with wall template that allows setting in advance the connections to the pipes, offering the possibility to connect the boiler once masonry works are completed.

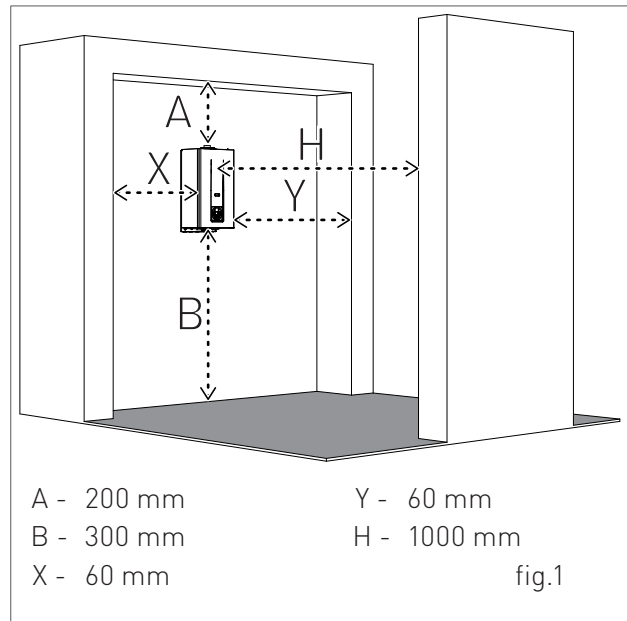

For water heater positioning, proceed as follows (see fig. 2):

1. Trace a line using a spirit level (min. length 25 cm) on the installation wall;
2. place the top of the template along the traced line respecting the distances of the water connections; then mark the two points to insert the two wall fastening screws, then trace the points for the flue system;
3. remove the template and drill the wall;
4. hang the water heater onto the wall fastening screws or onto the wall hanging bracket and perform the connections.

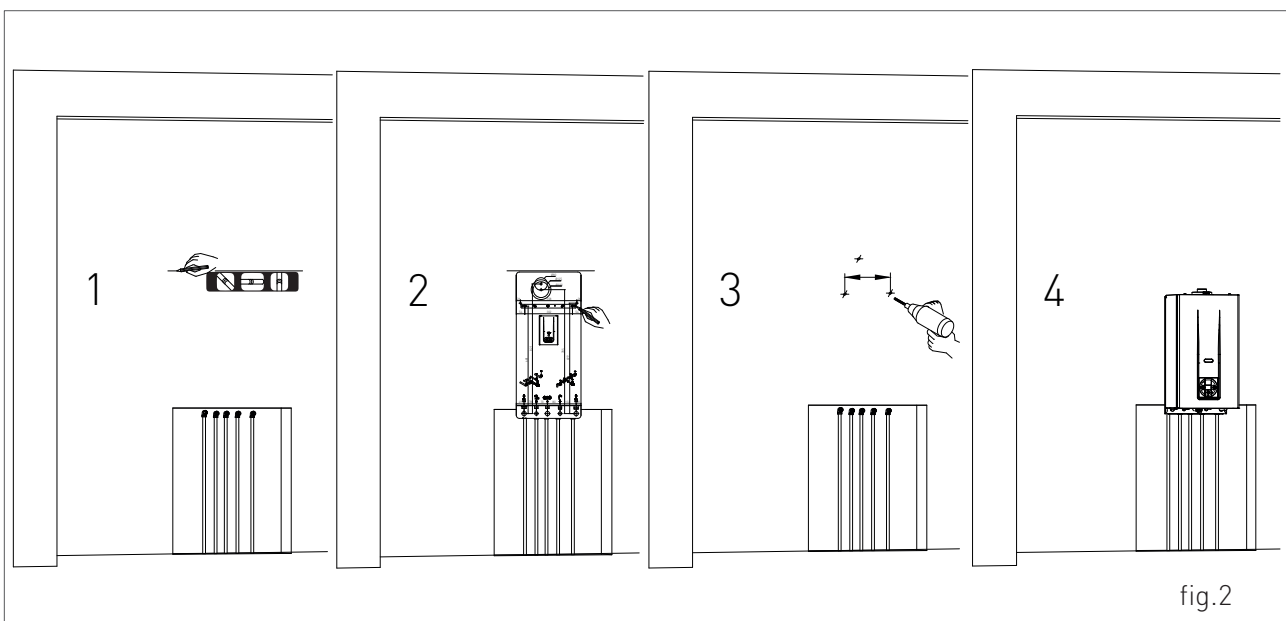

1. INSTALLATION

1.1.6. OVERALL DIMENSIONS

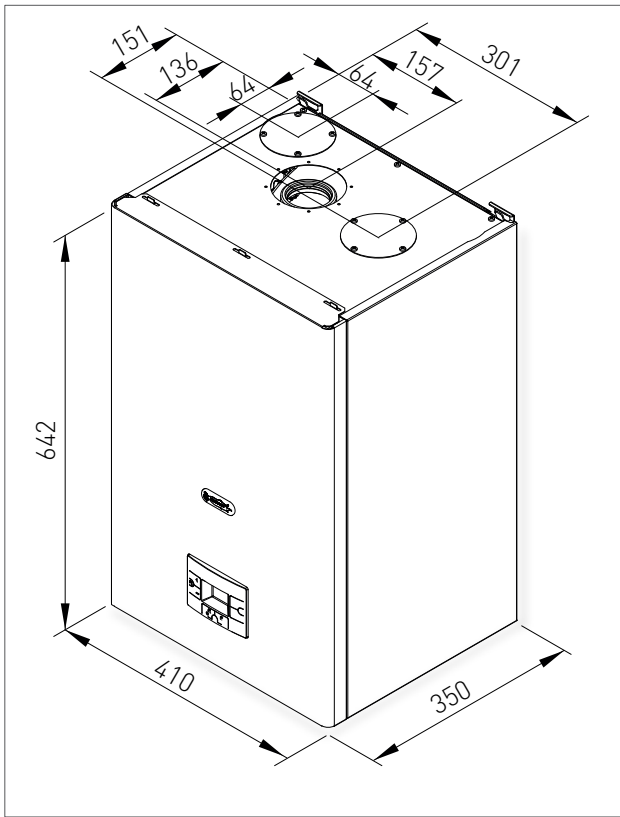

1.1.7. HYDRAULIC CONNECTIONS

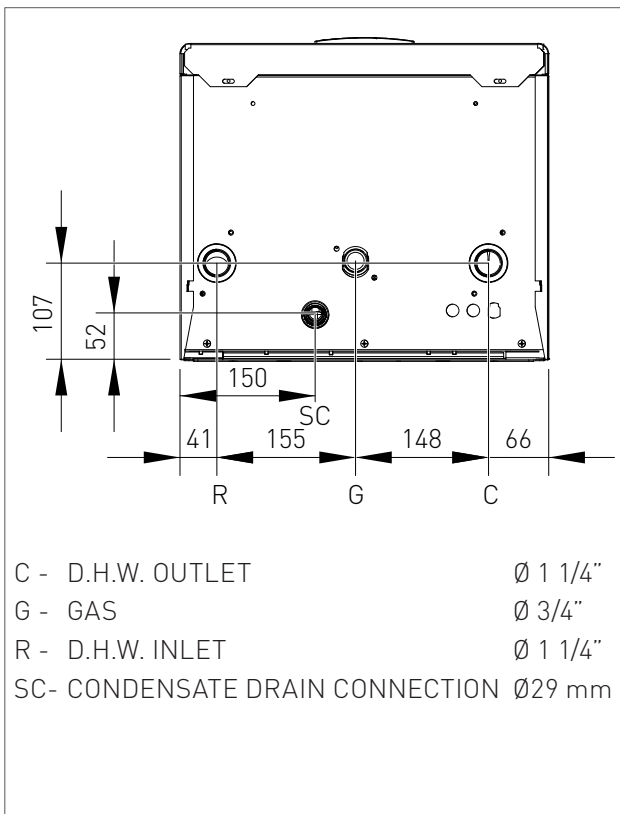

1.1.8. HYDRAULIC CONNECTION



DANGER

Make sure that the water and heating pipes are not used as grounding system for the electrical plant. They are not suitable for such use.



WARNING

To prevent voiding the warranty and ensure proper operation of the water heater, please wash the system (if possible when hot) with suitable pickling or descaling solutions in order to remove the impurities coming from pipes and radiators.



WARNING

If the water heater is installed in a hydrostatic position lower than those of the connected devices (radiators, fan coils, etc.), install the shut-off valves on the D.H.W. and heating circuits to ease the performance of the maintenance operations if it is necessary only to empty the water heater.



WARNING

When connecting the water heater to water supply, avoid excessive bending and recovery operations from any off axis positioning that may damage the pipes causing leaks, malfunction or early wear.



WARNING

In order to avoid any vibrations and noises, do not use pipes with small diameters or elbows with small radius and significant cut-off of the passage sections.



WARNING

Connect the water heater safety drains to a discharge funnel. The manufacturer is not responsible for any floods due to safety valve opening in case of plant overpressure.

In order to prevent limestone build-up and damages to the D.H.W. heat exchanger, the hardness of the domestic supply water should not exceed 15 °f. However, please check the characteristics of the water used and install suitable treating devices.

The heat exchanger coil cleaning frequency depends on the hardness of the supply water and on the presence of solid residues or impurities inside the water that are often present in case of recently installed plants. Based on the characteristics of the inlet water, the installation of suitable water treating devices is recommended, for residues presence please install a line filter.

The pressure of the cold inlet water should be between 0.5 and 6 bar. In case of higher pressure values, please install a pressure reducer upstream from the water heater.

1. INSTALLATION

1.1.9. FILLING THE CONDENSATE COLLECTION SIPHON

Before starting the water heater you have to fill the condensate collection siphon in order to avoid flue reflux through the siphon.

Fill the condensate collection siphon as follows (see fig. 1):

- > With a glass pour the water in the heat exchanger's flue exhaust duct outlet (see fig. 1), up to fill the condensate trap to the highest point "T" (fig. 1);
- > Connect the dedicated flexible condensate draining tube to a waste disposal system. The condensate can be drained directly in the sewerage system by inserting an easily serviceable siphon.

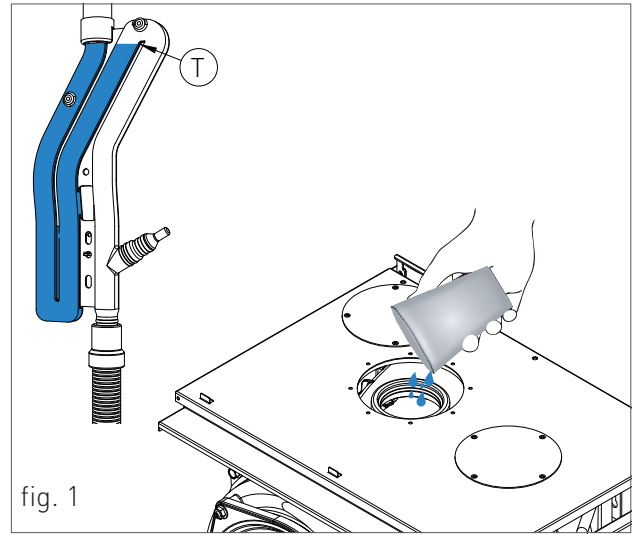

1.1.10. FROST PROTECTION KIT

Thanks to the optional electrical heating elements (code 50-00106), it is possible to protect the water heater up to an outside temperature of -10°C .

The electrical resistances kit is a frost protection system that activates when the water temperature goes below the value set at parameter P08 (see chapters 'ACCESSING AND PROGRAMMING THE PARAMETERS' and 'MIAB3114 PARAMETERS TABLE'). The electrical resistances heat the water heater pipes until a temperature 5°C higher than the value set at parameter P08 is reached.



ATTENTION

The system operates even if the water heater is in OFF mode, as long as it is electrically powered.

Whenever there is a risk of freezing and no optional kit of electrical heating elements is fitted on the water heater, the water circuit will have to be drained (see chapter 'DRAINING THE DOMESTIC HOT WATER SYSTEM').

1. INSTALLATION

1.1.11. GAS CONNECTION



DANGER

In order to connect the boiler gas connector to the supply pipe, use a stop seal of an appropriate size and material. The use of hemp, teflon tape or similar materials is strictly forbidden.

BEFORE PERFORMING THE GAS CONNECTION, MAKE SURE THAT:

- > the gas supply line complies with the standards and regulations in force;
- > the piping section suits the requested capacity and its length;
- > the piping is equipped with all safety and control devices required by the standards in force;
- > the internal and external seals of the gas inlet system are checked;
- > the boiler is suitable for use with the available type of gas by checking the boiler data plate (placed on the inner side of the front casing. If they do not match, please take the necessary measures to adapt the boiler to another type of gas (see chapter GAS CONVERSION));
- > the gas supply pressure falls within the values indicated on the data plate.

1.1.12. ELECTRICAL CONNECTION



DANGER

The boiler is electrically safe only if it is properly connected to an efficient earthing system, performed in compliance with the safety standards in force. Check this essential safety requirement is strictly recommended. If in doubt, request an accurate check of the electrical system performed by qualified staff, as the manufacturer is not responsible for any damages caused by lack of earthing system.

- > Make sure that the electrical systems is suitable for the maximum power absorbed by the boiler, value indicated on the data plate.
- > make sure that the cables section is appropriate for the maximum power absorbed by the boiler and that it is however not lower than 1 mm².
- > The equipment works with alternating current of 230 V and 50 Hz.



WARNING

Make sure that the live and neutral cables connection is performed in compliance with the wiring diagram (see chapter WIRING DIAGRAM).



WARNING

It is strictly forbidden the use of adaptors, multiple plugs and/or extensions for the general power supply of the boiler from the electrical network.

1. INSTALLATION

1.1.13. OPTIONAL ELECTRICAL CONNECTIONS

To wire the optional items below:

- **(CS) DISABLING THE D.H.W. MODE (BY CONTACT)**
- **(CR) OPEN THERM REMOTE CONTROL CODE 40-00017**
- **(CKR) FROST PROTECTION THROUGH ELECTRICAL RESISTANCES KIT CODE 50-00106**

operate on the terminal block placed inside the control panel as follows:



DANGER

Cut off the voltage from the main switch.

- › remove the boiler front casing (see chapter ACCESSING THE WATER HEATER).
- › remove the control panel back plate (see chapter ACCESSING THE P.C.B.).

- To disable the D.H.W. mode by contact, connect the two non-polarized conductors (for example a temperature thermostat or a solar control unit) to the 'CS' contacts of the terminal block (see fig. 1). It is possible to enable/disable the burner ignition request in D.H.W. mode in the following ways: (Example 1) - With 'CS' D.H.W. contact open, upon D.H.W. request, the flow-meter activates and the water heater starts. (Example 2) - With 'CS' D.H.W. contact closed, upon D.H.W. request, the flow-meter activates but the water heater doesn't start.
- For remote control, connect the two non-polarized conductors of the remote control (see 'CR' fig. 1).
- For frost protection through electrical resistances kit, connect the two conductors

to the 'CKR' contacts of the terminal block (see fig. 2).

After performing these operations, remount the back plate and the front casing.

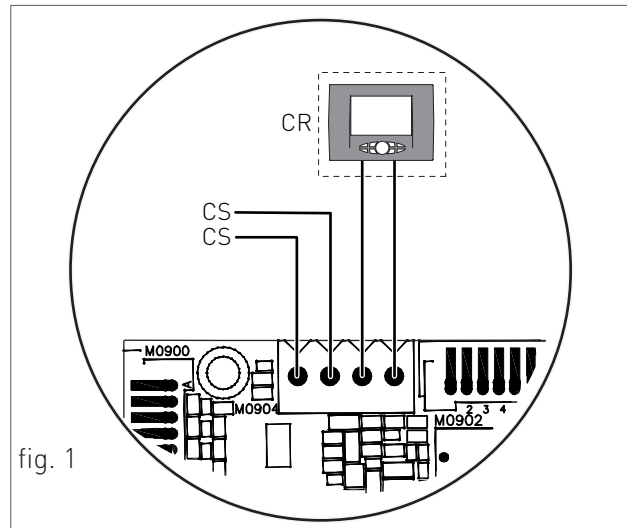

fig. 1

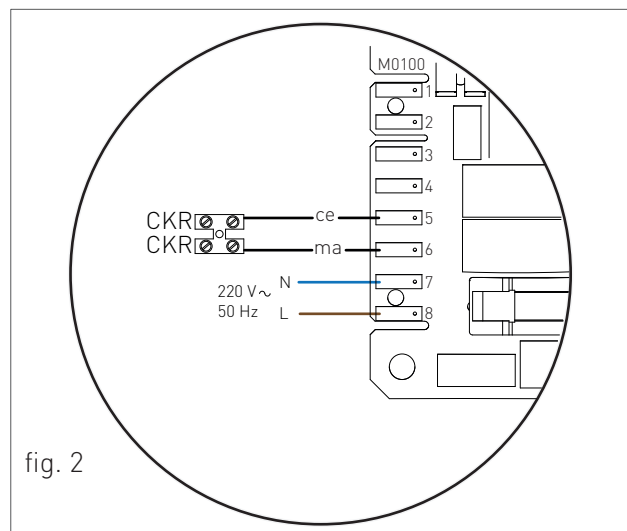

fig. 2

1. INSTALLATION

1.1.14. FUME EXHAUST FITTINGS



WARNING

In order to ensure proper operation and efficiency of the device you have to connect the water heater fume exhaust fitting to the fume exhaust duct using appropriate polypropylene flue fittings for condensing water heaters. It is recommended to install discharge systems



WARNING

You cannot use traditional flue fittings for the discharge ducts of the condensing water heaters, nor vice versa.



WARNING

For fumes exhaust and condensate collection, please follow the technical standards in force.

For all discharge ducts, with regard to the fumes path, you should provide an uphill slope (outwards) so as to favour the reflux of the condensate towards the combustion chamber, suitably realized to collect and drain acid condensate.

- › For all air suction ducts, with regard to the air path, you should provide an uphill slope (towards the water heater) so as to avoid the protrusion inside the duct of rain water, dust or foreign objects.
- › In case of horizontal co-axial system installation, correctly place the horizontal co-axial terminal suitably realized to respect the slopes inside the fumes duct and to protect the air suction duct from adverse weather conditions.
- › In order to discharge the fumes through a fumes exhaust duct carefully follow the technical standards in force.
- › Make sure that the discharge tube does not protrude inside the fumes exhaust duct, stop before it reaches the inner surface of the latter.

- › The discharge duct must be perpendicular with the opposite internal wall of the chimney or of the fumes exhaust duct (fig. 1).

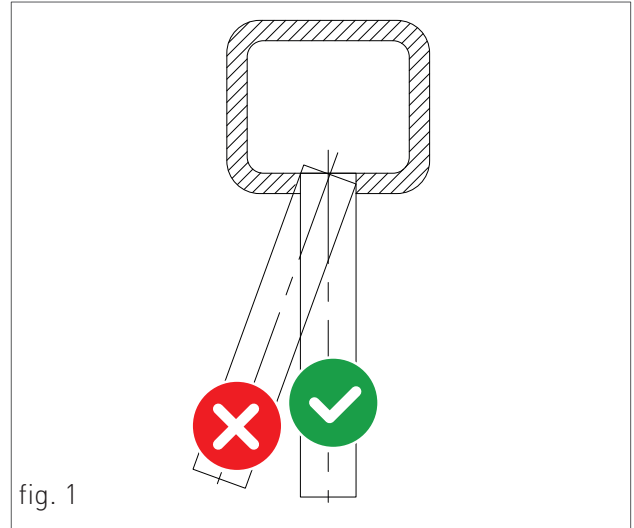

fig. 1

1.1.15. TYPES OF FUME EXHAUST SYSTEMS

**KIT AK 50 - HORIZONTAL CO-AXIAL SYSTEM
Ø80/125 INTERNAL POLYPROPYLENE DUCT
ADJUSTABLE AT 360°.**

It allows fumes discharge and air intake from external wall.

Suitable only for condensing boilers.

It allows fuel gas discharge and air intake for combustion through co-axial ducts, the external one for air intake, the plastic internal one for fumes discharge.

PLEASE SEE THE MAXIMUM DISCHARGE LENGTH IN THE TABLE IN CHAPTER "TECHNICAL DATA".

The maximum discharge length (or linear reference length) can be calculated summing the length of the linear tube and that equivalent to each additional curve with respect to the first.

Subsequent addition of a curve is similar to adding a linear length of tube according to the indications below:

co-axial curve Ø80/125 at 90° = 0.8 m

co-axial curve Ø80/125 at 45° = 0.5 m

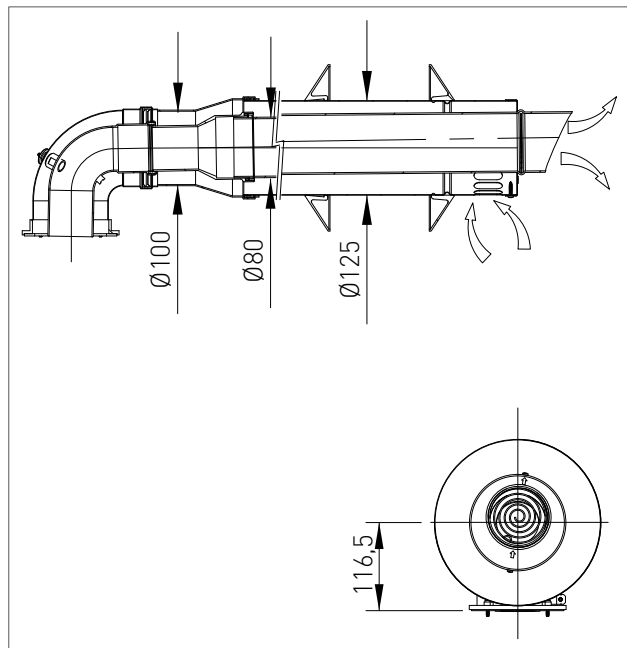
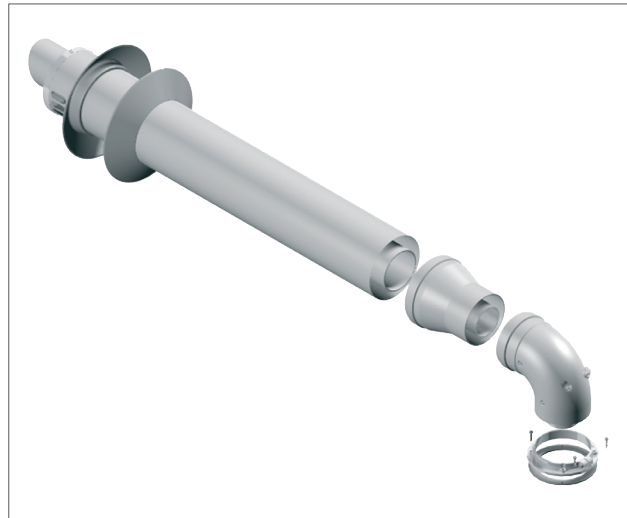

1. INSTALLATION

KIT H – HORIZONTAL TWIN PIPE FLUE KIT Ø80/80, IN POLYPROPYLENE, ADJUSTABLE AT 360°.

The twin pipe allows flue discharge through the flue exhaust duct and air intake from outside.

Suitable only for condensing boilers.

It allows discharging fuel gas and air suctioning for combustion through two separated ducts.

PLEASE SEE THE MAXIMUM DISCHARGE AND INTAKE LENGTH IN THE TABLE IN CHAPTER "TECHNICAL DATA".

The maximum discharge and intake length (or linear reference length) can be calculated summing the length of the linear tube and that equivalent to each additional curve with respect to the first.

Subsequent addition of a curve is similar to adding a linear length of tube according to the indications below:

curve Ø80 at 90°= 1.5 m

curve Ø80 at 45°= 0.8 m

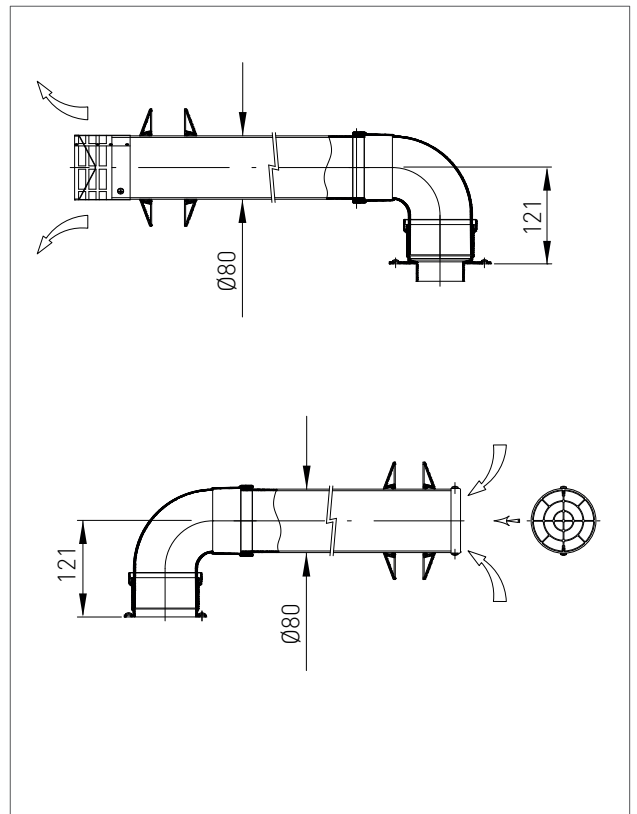
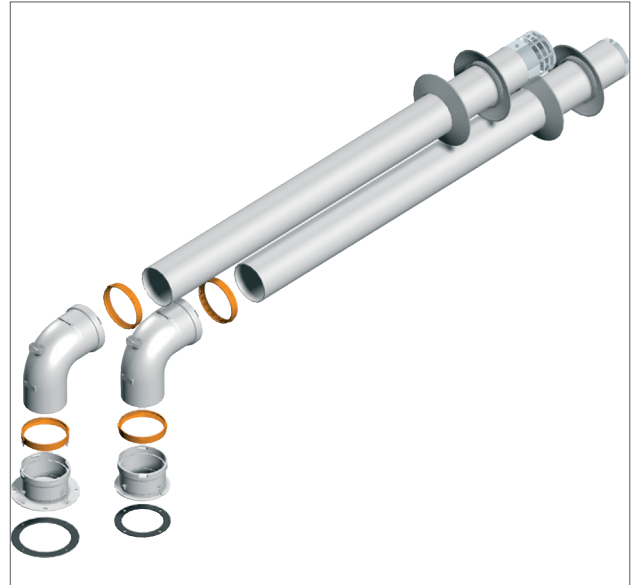

**KIT CK 50 - VERTICAL CO-AXIAL SYSTEM Ø80/125
INTERNAL POLYPROPYLENE DUCT.**

It allows fumes discharge and air intake directly from roof.

Suitable only for condensing boilers.

It allows fuel gas discharge and air intake for combustion through co-axial ducts, the external one for air intake, the plastic internal one for fumes discharge.

PLEASE SEE THE MAXIMUM DISCHARGE LENGTH IN THE TABLE IN CHAPTER "TECHNICAL DATA".

The maximum discharge length (or linear reference length) can be calculated summing the length of the linear tube and that equivalent to each additional curve with respect to the first.

Subsequent addition of a curve is similar to adding a linear length of tube according to the indications below:

curve Ø80/125 at 90° = 0.8 m

curve Ø80/125 at 45° = 0.5 m

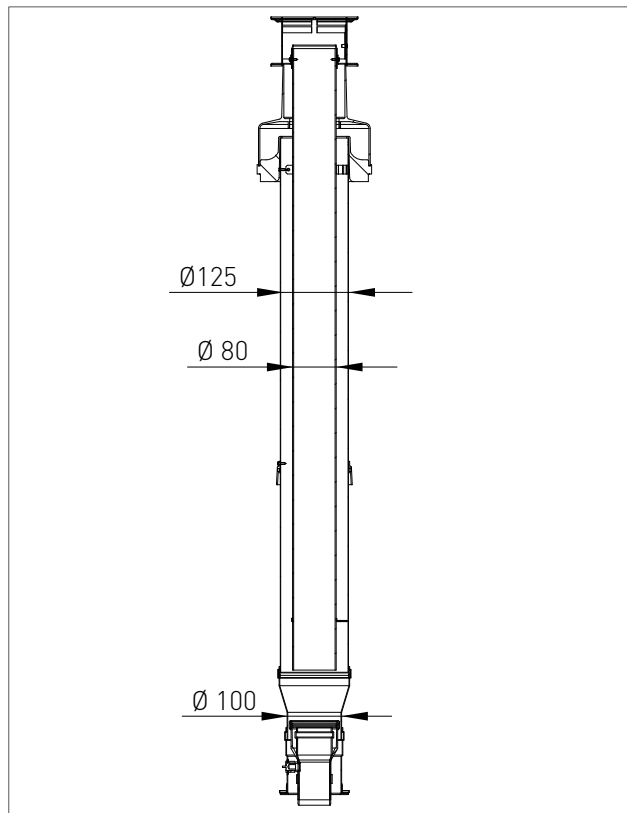
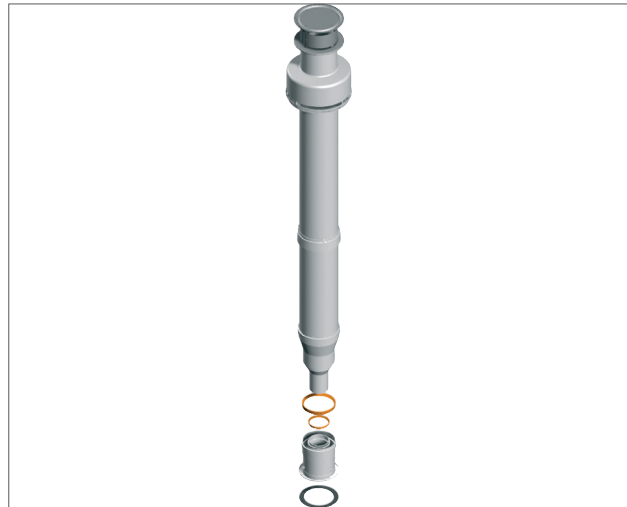

1. SERVICE CENTRE SECTION

All operations described below relative to first start-up, maintenance and replacement should be performed only by qualified personnel

2.1. FIRST START-UP



2.1.1. PRELIMINARY OPERATIONS FOR FIRST START-UP

The first start-up operations consist in checking the correct installation, adjustment and operation of the device. Proceed as follows:

- › check the inner system sealing in accordance with the indications provided by standard and regulations in forced;
- › check if the gas used is suitable for the water heater;
- › check if the gas capacity and relative pressures comply with those on the plate;
- › check the intervention of the safety device in case of lack of gas;
- › make sure that the device supply voltage corresponds with that on the plate (230 V – 50 Hz) and that the wiring is correct;
- › make sure that the grounding system works properly;
- › make sure that the combustion air adduction and fumes and condensate discharge take place properly in compliance with the Local and National Laws and Standards in force;
- › make sure that the fumes discharge tube and its connection to the fume exhaust duct comply with the requirements of the Local and National Laws and Standards;
- › make sure that the heating system gate valves are open;
- › make sure that there is no intake of gaseous products within the system;
- › make sure that there are no flammable liquids or materials near the device;
- › open the water heater gas tap and make sure that there are no gas leaks upstream from the device (the burner gas connection must be checked while the machine is running);
- › in case of new installation of the gas supply network, the air inside the tubes may block the device at its first start-up. You might have to repeat the start-up procedure to purge all the air inside the tube.

2.1.2. WATER HEATER COMMISSIONING

Proceed with water heater commissioning as follows:

- › power the water heater;
- › open the gas tap;
- › ignite the unit by pressing the button ;
- › open the D.H.W. taps at the maximum flow rate;
- › the unit is ignited.
- › If the flame is missing the board will repeat the start-up operations after post-ventilation (20 seconds).
- › You might have to repeat the start-up operation several times to release all air inside the gas tube. Before repeating the operation, wait at least 5 seconds from the last start-up attempt and unlock the water heater from "E01" error code by pressing the Reset  key.

2.1.3. CO₂ VALUE CHECK AND CALIBRATION



WARNING

The CO₂ value should be checked with the casing assembled, while the gas valve should be adjusted with the casing open.

To check and calibrate the CO₂ value to minimum and maximum heating power make sure that the appliance is not in OFF mode and proceed as follows:

FOR MINIMUM HEATING POWER

- › Access parameter 'P02' following the procedure described in chapter "ACCESSING AND PROGRAMMING THE PARAMETERS" and stay in edit mode until the calibration is completed (the maximum time before forced exiting the edit mode is 7 minutes).
- › Open several D.H.W. taps at the highest flow rate.
- › Insert the fumes analyser probe in the suitable 'PF' fumes inlet (fig. 1), then make sure that the CO₂ value complies with the requirements indicated in chapter "Technical data", otherwise unscrew the protection screw 'A' (fig. 2) and adjust using a 4 Allen wrench the screw '2' (fig. 2) of the Off-Set adjuster. To increase the CO₂ value, turn the screw clockwise and vice-versa if you want to decrease it.
- › Once completed the adjustment, tighten the protection screw 'A' (fig. 2) on the Off-Set adjuster.
- › Exit parameter 'P02' following the procedure described in chapter "ACCESSING AND PROGRAMMING THE PARAMETERS".

FOR MAXIMUM HEATING POWER

- › Open several D.H.W. taps at the highest flow rate.

- › Access parameter 'P03' following the procedure described in chapter "ACCESSING AND PROGRAMMING THE PARAMETERS" and stay in edit mode until the calibration is completed (the maximum time before forced exiting the edit mode is 7 minutes).
- › Make sure that the CO₂ value complies with the indications in "Technical data", otherwise adjust using screw '1' (fig. 2) of the gas flow adjuster. To increase the CO₂ value, turn the screw anti-clockwise and vice-versa if you want to decrease it.
- › After each adjustment variation on screw '1' (fig. 2) of the gas flow adjuster you have to wait for the boiler to stabilize itself to the set value (about 30 seconds).
- › Enter again the parameter 'P02' and make sure that the CO₂ value did not change to minimum, if changed repeat the calibration described in the previous paragraph.

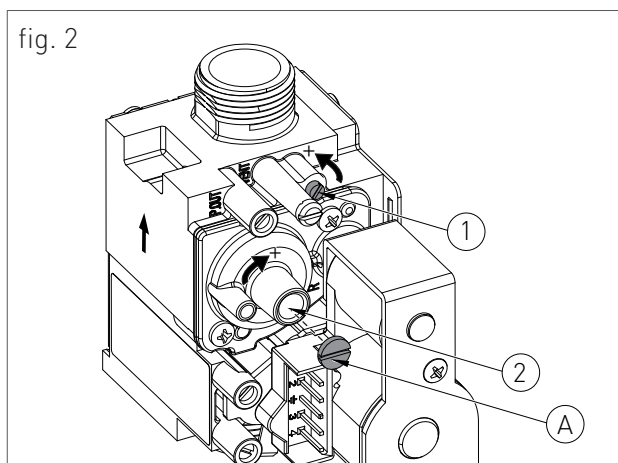
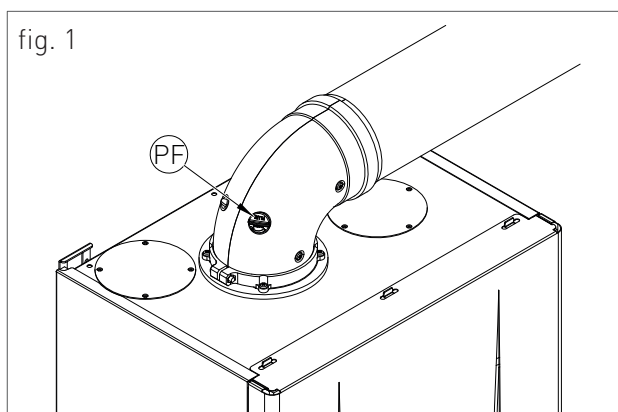

2.1.4. ACCESSING AND PROGRAMMING THE PARAMETERS

To access the parameters menu and adjust their values, follow the procedure below:

1. Press the "⏻" button to select the OFF mode.

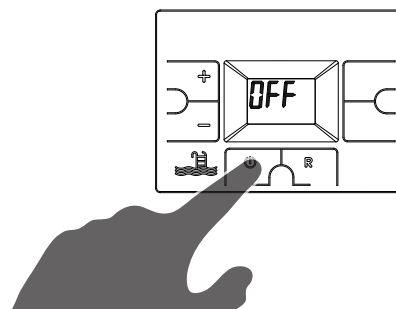

2. Press and hold both the "R" and "+" buttons and wait for 'P00' to appear on the display, then release the buttons.

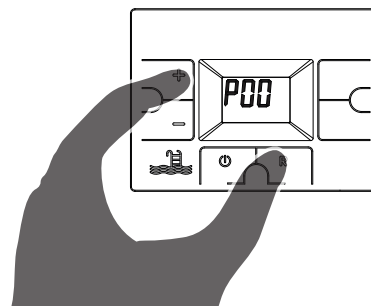

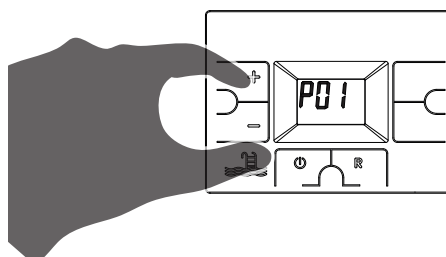

3. Use the keys "+" and "-" to select the parameter to be edited.



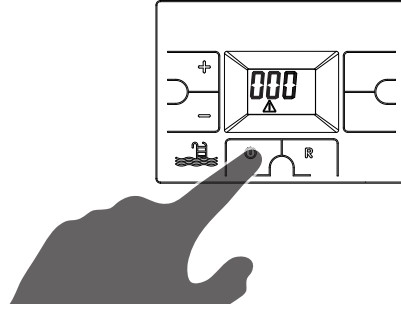

2. FIRST START-UP

4. Keep the “” button pressed until the parameter value is displayed.

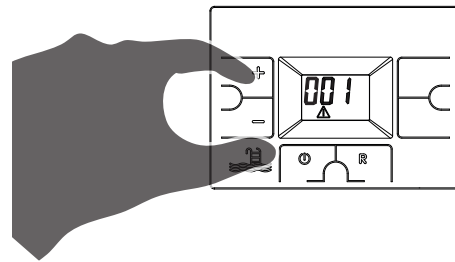

5. Use the ‘’ and ‘’ buttons to change the parameter value.



6. Keep the “” button pressed until the parameter is displayed in order to confirm the modified value.

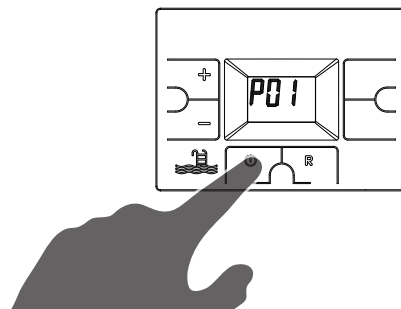

7. To quit the parameters menu, press the **R** button until 'OFF' is displayed.

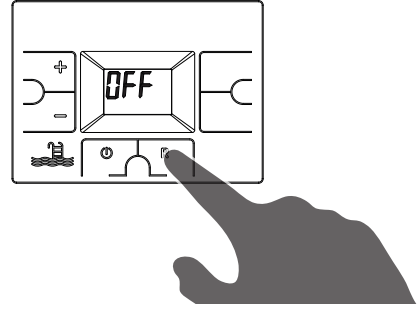

2. FIRST START-UP

2.1.5. MIAB3114 PARAMETERS TABLE

PARAMETER	DESCRIPTION	RANGE	FUNCTION
P00	SELECTION OF THE FIRE RATING	0 - 2	0 = 24 KW 1 = 28 KW 2 = 34 KW
P01	GAS TYPE SELECTION ATTENTION: READ THE INSTRUCTION IN CHAPTER 'GAS TRANSFORMATION' BEFORE CHANGING THIS PARAMETER.	0 - 1	0 = NATURAL GAS 1 = LPG
P02	FAN MINIMUM SPEED ADJUSTMENT THROUGH THIS PARAMETER YOU CAN SET THE FAN MINIMUM SPEED CORRESPONDING TO THE MINIMUM POWER OF THE BURNER. THE VALUE IS PRE-SET BASED ON THE SET POWER (SEE PARAMETER P00) AND ON THE GAS TYPE (SEE PARAMETER P01).	43 - 133	VALUE EXPRESSED IN HERTZ (1HZ = 30 RPM)
P03	FAN MAXIMUM SPEED ADJUSTMENT THROUGH THIS PARAMETER YOU CAN SET THE MAXIMUM FAN SPEED CORRESPONDING TO THE MAXIMUM POWER OF THE BURNER. THE VALUE IS PRE-SET BASED ON THE SET POWER (SEE PARAMETER P00) AND ON THE GAS TYPE (SEE PARAMETER P01).	40 - 290	VALUE EXPRESSED IN HERTZ (1HZ = 30 RPM)
P04	STARTING STEP ADJUSTMENT THROUGH THIS PARAMETER YOU CAN SET THE FAN SPEED DURING THE START-UP. THE VALUE IS PRE-SET BASED ON THE SET POWER (SEE PARAMETER P00) AND ON THE GAS TYPE (SEE PARAMETER P01).	40 - 255	VALUE EXPRESSED IN HERTZ (1HZ = 30 RPM)
P05	MAXIMUM DOMESTIC SETPOINT THROUGH THIS PARAMETER YOU CAN SET THE USER-ADJUSTABLE MAXIMUM DOMESTIC TEMPERATURE.	30 - 45	VALUE EXPRESSED IN °C (PRE-SET AT 45°C)

2. FIRST START-UP

PARAMETER	DESCRIPTION	RANGE	FUNCTION
P06	<p>MINIMUM D.H.W FLOW RATE SETTING</p> <p>THROUGH THIS PARAMETER YOU CAN SET THE MINIMUM D.H.W. FLOW RATE NECESSARY TO ACTIVATE THE WATER HEATER.</p> <p>THE VALUE IS PRE-SET BASED ON THE CHOSEN POWER (SEE PARAMETER P00).</p>	9 - 40	THE VALUE IS EXPRESSED IN l/min (SET BY DEFAULT AT 20 l/min)
P07	<p>ADDITIONAL POST-VENTILATION TIMING</p> <p>THROUGH THIS PARAMETER YOU CAN SET A PERIOD OF OPERATION, ADDITIONAL TO THE 20 STANDARD SECONDS OF THE FAN, AFTER THE BURNER SHUTDOWN.</p>	0 - 120	VALUE EXPRESSED IN MULTIPLES OF 5 SECONDS (PRE-SET AT 6 X 5 = 30 SECONDS)
P08	<p>FROST PROTECTION TEMPERATURE SETTING (D.H.W. MODE)</p> <p>THROUGH THIS PARAMETER, IT IS POSSIBLE TO SET THE D.H.W. WATER TEMPERATURE VALUE FOR THE ACTIVATION OF THE FROST PROTECTION SYSTEM (SEE CHAPTER 'ANTI-FREEZE PROTECTION').</p>	4 - 12	THE VALUE IS EXPRESSED IN °C (SET BY DEFAULT AT 5 °C)
P09	<p>HEATING RUN-UP</p> <p>THROUGH THIS PARAMETER YOU CAN SET THE TIME, DURING START-UP PHASE, NECESSARY FOR THE BOILER TO REACH THE MAXIMUM SET POWER (ON THE HEATING SIDE).</p>	0 - 4	<p>0 = (DISABLED)</p> <hr/> <p>1 = 50 SECONDS</p> <hr/> <p>2 = 100 SECONDS (SET BY DEFAULT)</p> <hr/> <p>3 = 200 SECONDS</p> <hr/> <p>4 = 400 SECONDS</p>
P10	<p>SETPOINT SAFETY SUPPLY TEMPERATURE</p>	30 - 48	THE VALUE IS EXPRESSED IN °C (SET BY DEFAULT AT 45 °C)

2.2. MAINTENANCE

2.2.6. GENERAL MAINTENANCE
WARNINGS**DANGER**

Before each components cleaning or replacement operation, ALWAYS cut off the POWER, WATER and GAS supply of the water heater.

**WARNING**

To ensure greater life span and proper operation of the device, during the maintenance operations use only original spare parts.

**ATTENTION**

To ensure the efficiency and safety of the device, a full service must be undertaken on an annual basis. The operations described below, are essential to the validity of the standard Flexiheat warranty and must be performed by professionally qualified personnel

Please perform the following operations once a year:

- › check the sealing of the water components, and replace if necessary the gaskets;
- › check that the wiring is performed in compliance with the requirements in the water heater instruction manual;
- › check the wiring inside the control panel;
- › remove and clean the burner from oxidation;
- › check the integrity and the position of the sealed chamber sealing gasket;
- › check the primary exchanger, if necessary, clean it;
- › check the operation of the gas light up and safety systems. If necessary, remove and clean the flame detection and light up electrodes from incrustations paying attention to respect the distances with respect to the burner;
- › check the sealing of the gas components, and replace if necessary the gaskets;
- › visually check the flame and the condition of the combustion chamber;
- › if necessary make sure that the combustion is suitably adjusted and if required proceed as indicated in section "CO2 VALUE CHECK AND CALIBRATION";
- › periodically check the integrity of the fume exhaustion system for safety and proper operation;
- › make sure that the permanent ventilation outlets are present, correctly sized and functioning, based on the installed devices. Respect the requirements provided by Local and National legislation;
- › check the proper operation of the condensate draining system, including the devices outside the water heater such as condensate collection devices installed along the path of the fume exhaust duct or neutralization devices for acid condensate; check that the liquid flow is not obstructed and that there are no combustion gas refluxes inside the internal system;
- › check the flow and temperature of domestic hot water.

2.2.7. TECHNICAL DATA

Model		RSP 34
Gas category		I12H3P
Flue system type	type	B23-B23p-B33-B53-C13-C33-C4 3-C53-C63-C73-C83-C93
Heat Input max (D.H.W.)	kW	34
Heat Input min (D.H.W.)	kW	4,10
Heat Input min LPG	kW	4,10
Nominal useful output at 50/30	kW	36,45
Minimum useful output at 50/30	kW	4,50
Maximum combustion efficiency	%	99
Minimum combustion efficiency	%	99,6
Efficiency at the nominale heat input	%	107,2
Efficiency at the minimum heat input	%	109,8
Flue efficiency losses with burner on (Heat Input max.)	%	1
Flue efficiency losses with burner on (Heat Input min.)	%	0,40
Fumes temperature - Heat Input max.	°C	49
Fumes temperature - Heat Input min.	°C	35
CO ₂ - Heat Input max. - G20	%	9,45 - 9,25
CO ₂ - Heat Input min. - G20	%	9,05 - 8,85
CO ₂ - Heat Input max. - G30	%	11,40 - 11,20
CO ₂ - Heat Input min. - G30	%	10,75 - 10,55
CO ₂ - Heat Input max. - G31	%	10,55 - 10,35
CO ₂ - Heat Input min. - G31	%	9,90 - 9,70
CO - Heat Input max.	ppm	75
CO - Heat Input min.	ppm	2
Fumes mass - Heat Input max.	g/s	14,80
Fumes mass - Heat Input min.	g/s	1,85
Weighted NO _x (0% O ₂) ppm	ppm	31
Weighted NO _x (0% O ₂) on GCV mg/kWh	mg/kWh	49
Domestic Hot Water (D.H.W.) circuit		
Temperature setting - D.H.W.	°C	25-45
Max. operating pressure - D.H.W.	bar	8 0,5
Min. operating pressure - D.H.W.	bar	
Dimensions		
Width	mm	410
Depth	mm	350
Height	mm	642
Gross weight	Kg	27
Hydraulic Connections		
Cold water inlet	∅	1 1/4"
D.H.W. outlet	∅	1 1/4"
Gas	∅	3/4"
Flue systems		
Fan - Max. available pressure	Pa	91

2. MAINTENANCE

Fan - Min. available pressure	Pa	5,8
Max. Flue length Ø60/100 - Horiz. Conc.	m	2
Flue bend 45° MF Ø60/100 - Pressure loss	m	0,6
Flue bend 90° MF Ø60/100 - Pressure loss	m	1
Flue extension MF Ø60/100 L=1000 - Pressure loss	m	1
Max. Flue length Ø80/125 - Horiz. Conc.	m	10
Flue bend 45° MF Ø80/125 - Pressure loss	m	0,5
Flue bend 90° MF Ø80/125 - Pressure loss	m	0,8
Flue extension MF Ø80/125 L=1000 - Pressure loss	m	1
Max. Flue length Ø50/50 - Horiz. Twin	m	3
Max. Flue length Ø60/60 - Horiz. Twin	m	18
Flue adapter Ø80/60 MF - Pressure loss	m	0,4
Flue bend 45° MF Ø60 - Pressure loss	m	0,8
Flue bend 90° MF Ø60 - Pressure loss	m	1,5
Flue extension MF Ø60 L=1000 - Pressure loss	m	1
T-connection MF Ø60 - Pressure loss	m	3,5
Max Flue length Ø80/80 - Horiz. Twin	m	60
Max. Flue length Ø50 - Horiz. Pipe	m	2
Max. Flue length Ø60 - Horiz. Pipe	m	14
Max. Flue length Ø80 - Horiz. Pipe	m	35
Flue bend 45° MF Ø80 - Pressure loss	m	0,8
Flue bend 90° MF Ø80 - Pressure loss	m	1,5
Flue extension MF Ø80 L=1000 - Pressure loss	m	1
T-connection MF Ø80 - Pressure loss	m	3,5
Max. Flue length Ø60/100 - Vert.	m	2
Conc. Max. Flue length Ø80/125 -	m	10
Vert. Conc. Max. Flue length Ø50/50 -	m	3
Vert . Twin Max. Flue length Ø60/60 -	m	18
Vert . Twin Max. Flue length Ø80/80 -	m	60
Vert . Twin Max. Flue length Ø50 -	m	2
Vert. Pipe Max. Flue length Ø60 - Vert.	m	14
Pipe Max. Flue length Ø80 - Vert. Pipe	m	35
Electrical specifications		
Voltage-frequency	V/Hz	220-230/50
Nominal power consumption Electric	A	0,75
power with boiler OFF	W	3.50
Max Power consumption	W	38
Protection rating	IP	X5D
Gas supply		
Supply pressure - G20	mbar	20
Supply pressure min. - G20	mbar	17
Supply pressure max. - G20	mbar	25
Fan speed Max. D.H.W. output - G20	Hz	203
Fan speed Min. D.H.W. output - G20	Hz	53
Gas consumption - G20	m ³ /h	3,60
Supply pressure - G30	mbar	28-30
Supply pressure min. - G30	mbar	20

2. MAINTENANCE

Supply pressure max. - G30	mbar	35
Fan speed Max. D.H.W. output - G30	Hz	195
Fan speed Min. D.H.W. output - G30	Hz	55
Gas consumption - G30	kg/h	2,68
Supply pressure - G31	mbar	37
Supply pressure min. - G31	mbar	25
Supply pressure max. - G31	mbar	45
Fan speed Max. D.H.W. output - G31	Hz	203
Fan speed Min. D.H.W. output - G31	Hz	55
Gas consumption - G31	kg/h	2,64

2.2.8. TECHNICAL ASSEMBLY

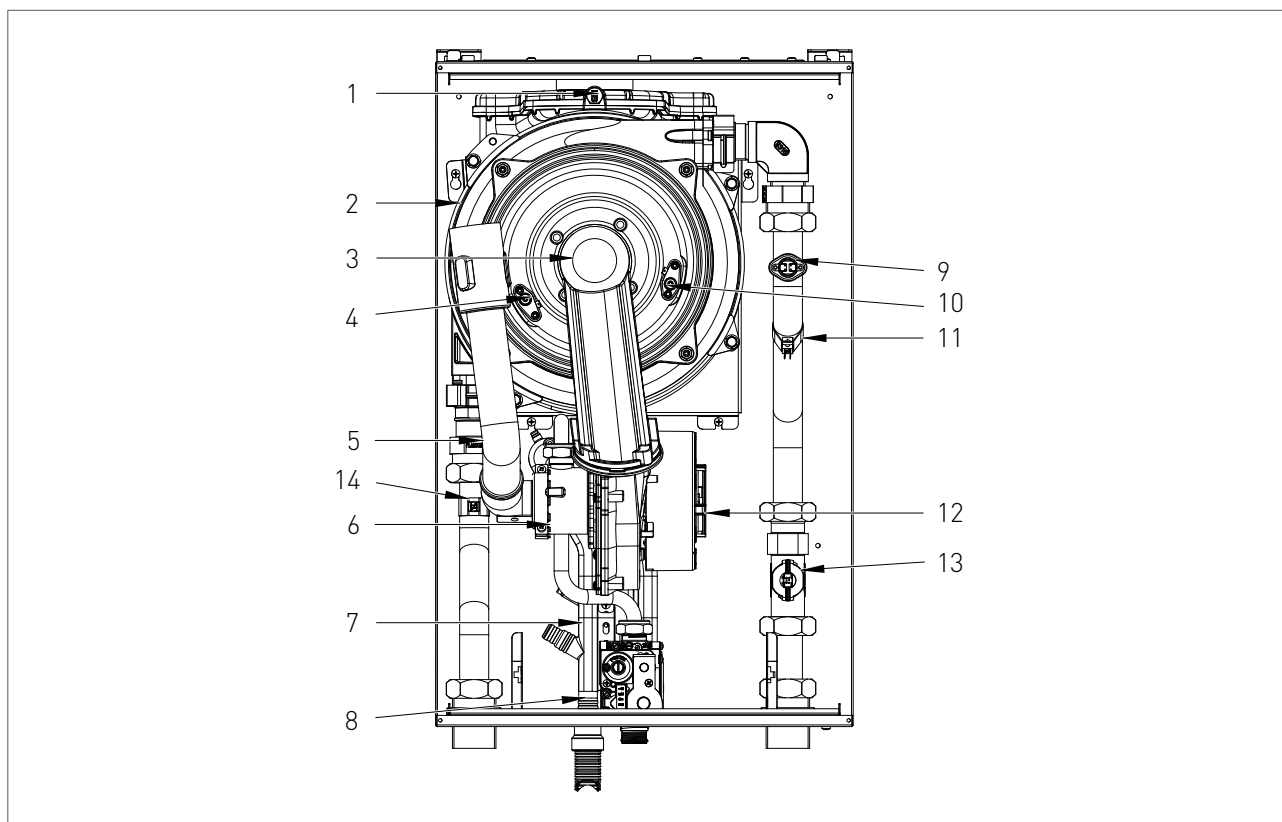

KEY

1. FLUE SAFETY THERMOFUSE
2. CONDENSING HEAT EXCHANGER
3. BURNER UNIT
4. DETECTION ELECTRODE
5. AIR SUCTION TUBE
6. VENTURI
7. CONDENSATE DRAIN SIPHON
8. GAS VALVE
9. SAFETY THERMOSTAT
10. LIGHT UP ELECTRODE
11. DOMESTIC HOT WATER OUTLET PROBE
12. FAN
13. FLUXMETER
14. DOMESTIC HOT WATER INLET PROBE

2.2.9. HYDRAULIC BOARD

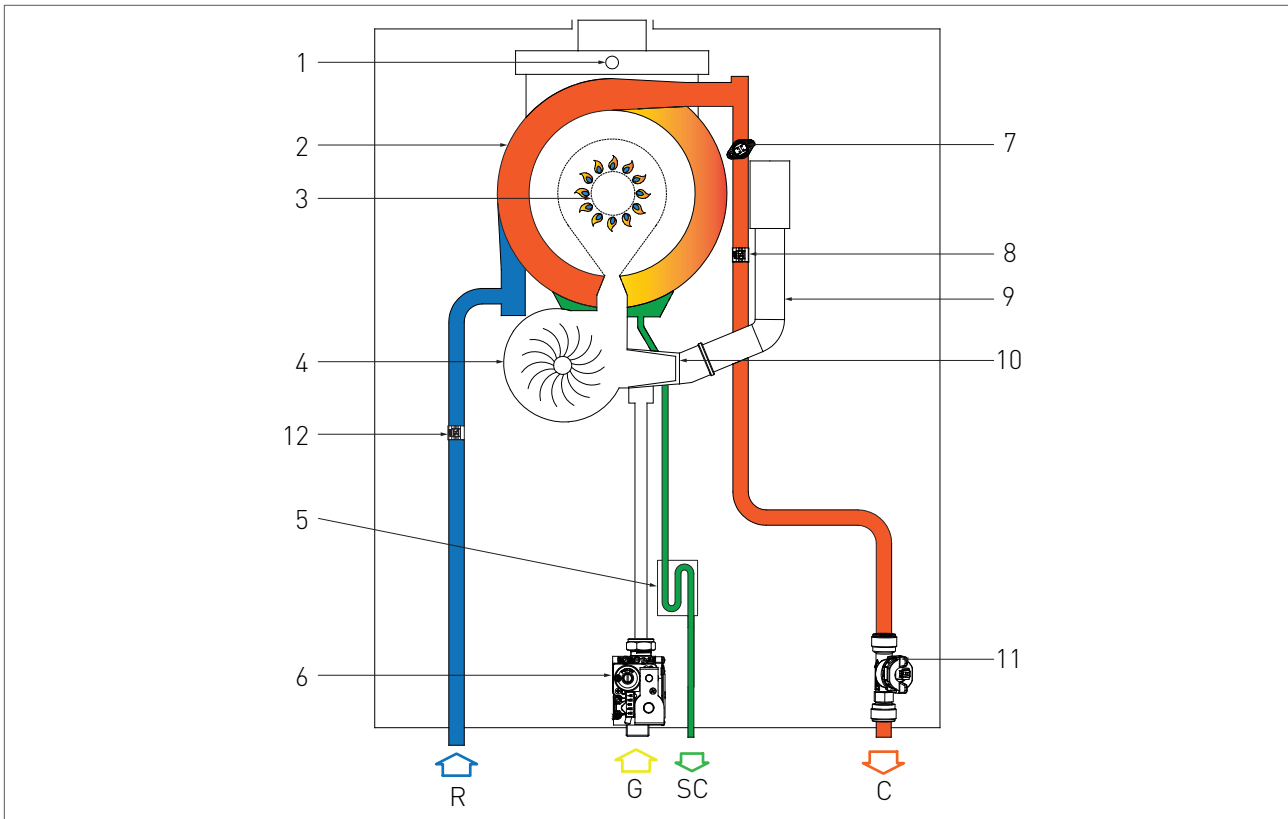

KEY

- C. DOMESTIC HOT WATER OUTLET
- G. GAS INLET
- SC. CONDENSATE DRAIN CONNECTION
- R. DOMESTIC HOT WATER INLET

- 1. FLUE SAFETY THERMOFUSE
- 2. CONDENSING HEAT EXCHANGER
- 3. BURNER UNIT
- 4. FAN
- 5. CONDENSATE DRAIN CONNECTION
- 6. GAS VALVE
- 7. SAFETY THERMOSTAT
- 8. DOMESTIC HOT WATER OUTLET PROBE
- 9. AIR SUCTION TUBE
- 10. VENTURI
- 11. FLUXMETER
- 12. DOMESTIC HOT WATER INLET PROBE

2. MAINTENANCE

2.2.10. WIRING DIAGRAM

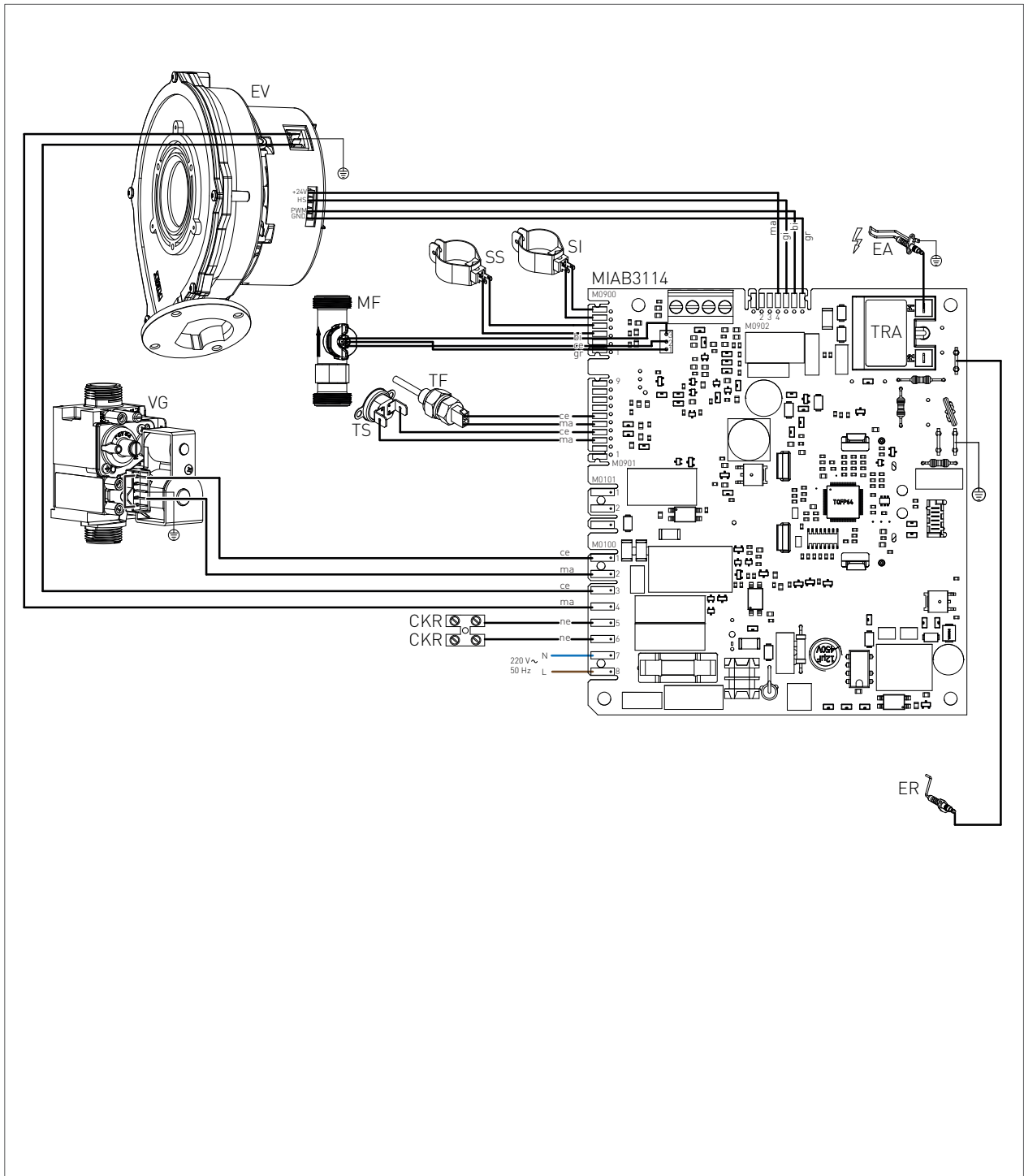

ER: DETECTION ELECTRODE	MF: FLUXMETER	NE: BLACK	CKR: CONTACT FOR ANTIFREEZE
EA: START-UP ELECTRODE		CE: BLUE	VIA - OPTIONAL ELECTRIC
EV: ELECTRIC FAN	SS: D.H.W. OUTLET PROBE	MA: BROWN	RESISTANCE KIT (COD : 50-00106)
VG: GAS VALVE	CS: D.H.W. PRODUCTION CONTACT	AR: ORANGE	
TRA: START-UP TRANSFORMER	SI: D.H.W. INLET PROBE	GI: YELLOW	
TF: FUMES THERMOFUSE (102°C)	L: LINE	BI: WHITE	
TS: SAFETY THERMOSTAT	N: NEUTRAL	GR: GREY	

2.2.11. ACCESSING THE WATER HEATER

For the majority of the control and maintenance operations you have to remove one or more panels of the casing.

The side panels can be removed only after removing the front panel.

To intervene on the front of the water heater proceed as follows:

- › remove the fastening screws (1 - fig.1) placed on the lower edge of the front panel;
- › grab the front panel from the bottom and remove it pulling it to yourself and then upwards (see fig. 1).

To intervene on the side panels of the water heater proceed as follows:

- › remove the fastening screws (2 - fig.1) placed on the front edge of the side panel;
- › grab the bottom of the panel and remove it by moving it sideways and then pulling it upwards (see fig. 1).

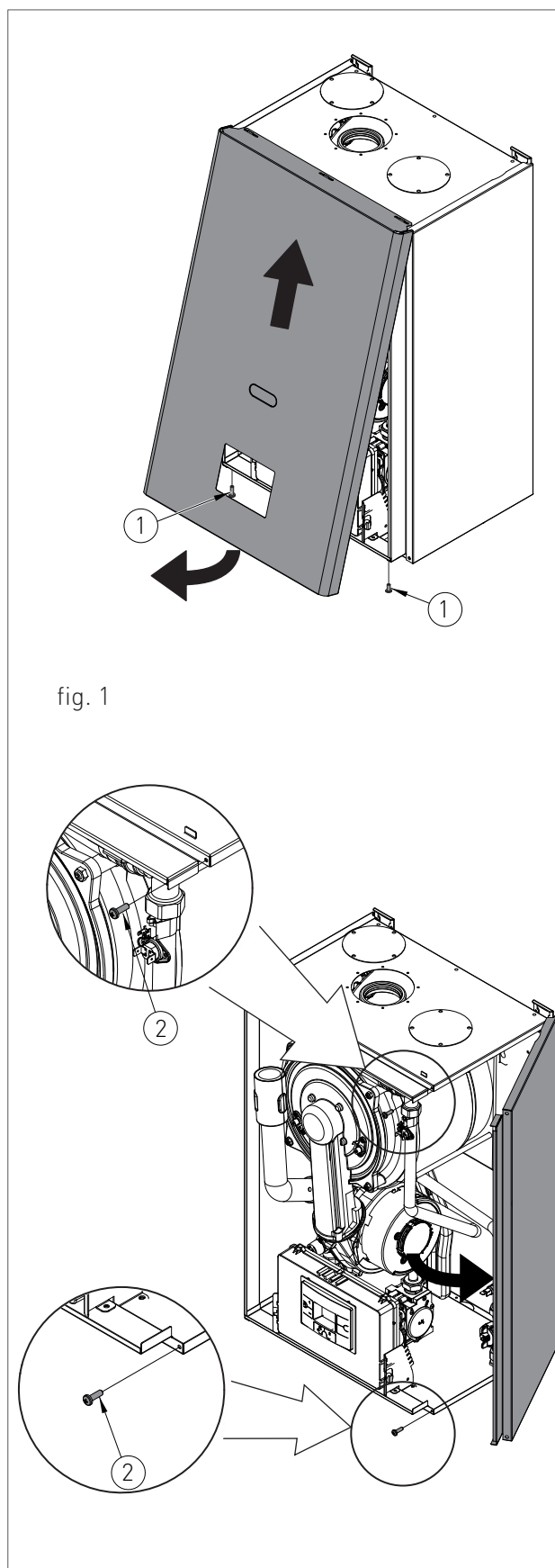

fig. 1

2.2.12. ACCESSING THE ELECTRONIC BOARD

In order to intervene on the wirings of the control panel, please proceed as follows:



DANGER

Cut off the voltage from the main switch.

- > Grab at the same time the support brackets of the control panel (fig. 1) loosening them and turn the panel downwards;
- > unscrew the two fastening screws 1 - fig. 1;
- > disengage the four hooks '2' - fig. 1;
- > remove the crankcase pulling it upwards.

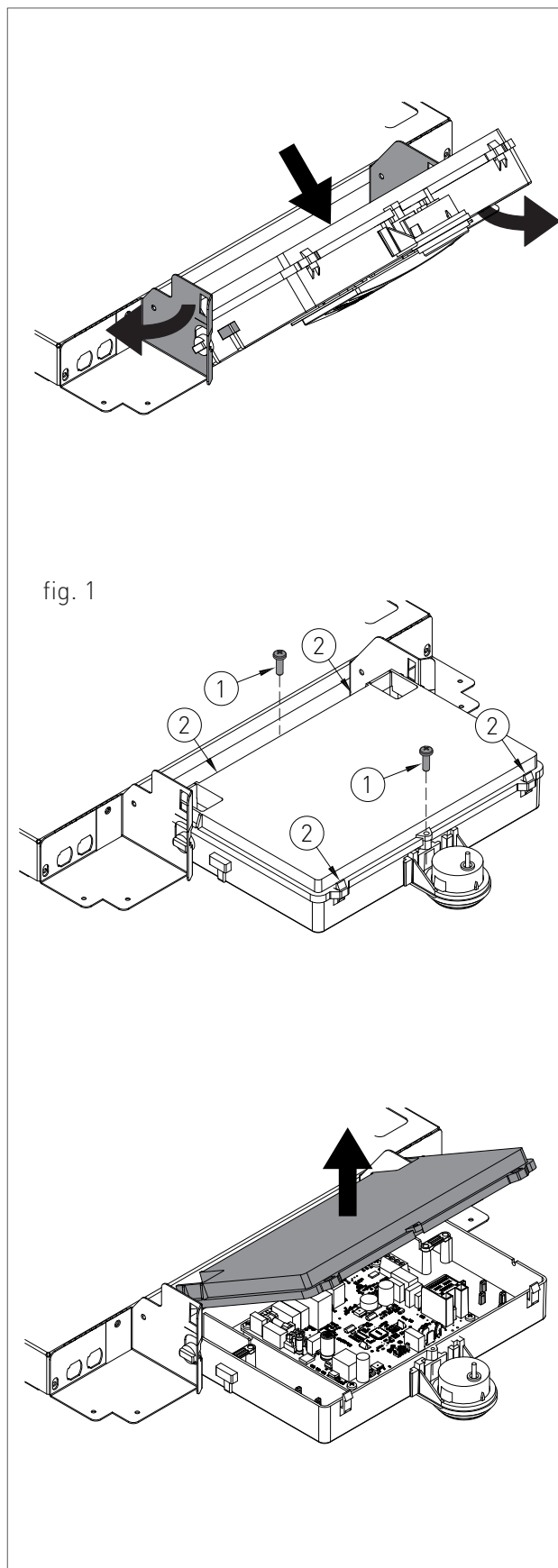

2.2.13. EMPTYING THE DOMESTIC SYSTEM

If there is freezing risk, you have to empty the domestic system as follows:

- › close the main supply tap of the water supply network;
- › open all cold and hot water taps;
- › after completing all operations, close the discharge tap and all previously opened water taps.

2. MAINTENANCE

2.2.14. FAULT SIGNALLING CODES

CODE	FAULT	POSSIBLE CAUSE	SOLUTION	RESET
E01	FLAME BLOCK	NO FLAME LIGHT UP		MANUAL RESET (PRESS THE RESET Ⓡ KEY).
		GAS MISSING;	CHECK THE ADDUCTION NETWORK;	
		MASS OR BROKEN START-UP ELECTRODE;	REPLACE IT;	
		GAS VALVE BROKEN;	REPLACE IT;	
		SLOW LIGHT UP TOO LOW ADJUSTMENT;	ADJUST MINIMUM OR SLOW LIGHT UP;	
		VALVE INFEED PRESSURE TOO HIGH (ONLY FOR GPL WATER HEATERS).	CHECK THE MAXIMUM ADJUSTMENT PRESSURE	
		WITH FLAME LIGHT UP		
		DETECTION ELECTRODE BROKEN;	REPLACE IT;	
		DETECTION ELECTRODE CABLE DISCONNECTED.	CHECK THE WIRING.	
		ELECTRICAL CURRENT PHASE-PHASE	IF THE TENSION MEASURES BETWEEN NEUTRAL AND GROUND IS ALMOST EQUAL TO THE ONE MEASURED BETWEEN PHASE AND GROUND, YOU HAVE TO INSTALL A PHASE-PHASE TRANSFORMER KIT (COD. 88021LA)	
E02	SAFETY THERMOSTAT	THERMOSTAT CABLE DISCONNECTED;	CHECK THE WIRING:	MANUAL RESET (PRESS THE RESET Ⓡ KEY).
		BROKEN THERMOSTAT.	REPLACE IT.	
E03	FUMES SAFETY THERMOFUSE (102°C)	THERMOFUSE BROKEN;	REPLACE IT;	MANUAL RESET (PRESS THE RESET Ⓡ KEY).
		THERMOFUSE CABLE DISCONNECTED.	CHECK THE WIRING.	

2. MAINTENANCE

CODE	FAULT	POSSIBLE CAUSE	SOLUTION	RESET
E05	INLET PROBE (COLD WATER)	BROKEN OR INCORRECTLY CALIBRATED PROBE (RESISTANCE VALUE 10 KOHM AT 25 °C NTC);	REPLACE IT;	AUTOMATIC.
		DISCONNECTED OR WET PROBE CONNECTOR.	CHECK THE WIRING.	
E06	DOMESTIC CIRCUIT OUTLET PROBE	BROKEN OR INCORRECTLY CALIBRATED PROBE (RESISTANCE VALUE 10 KOHM AT 25 °C NTC);	REPLACE IT;	AUTOMATIC.
		DISCONNECTED OR WET PROBE CONNECTOR.	CHECK THE WIRING.	
E15	DOMESTIC CIRCUIT INLET PROBE	BROKEN OR INCORRECTLY CALIBRATED PROBE (RESISTANCE VALUE 10 KOHM AT 25 °C NTC);	REPLACE IT;	AUTOMATIC.
		DISCONNECTED OR WET PROBE CONNECTOR.	CHECK THE WIRING.	
E16	ELECTRIC FAN	ELECTRIC FAN BOARD BROKEN;	REPLACE IT;	AUTOMATIC.
		ELECTRIC FAN BROKEN;	REPLACE IT;	
		FAULTY POWER SUPPLY CABLE.	REPLACE IT.	
E22	PARAMETERS PROGRAMMING REQUEST	MICRO=PROCESSOR MEMORY LOSS.	PARAMETERS REPROGRAMMING.	MANUAL RESET (CUT OFF THE TENSION).
E31	REMOTE CONTROLLER INCOMPATIBLE	INDICATES THAT THE REMOTE CONTROLLER CONNECTED TO THE WATER HEATER IS NOT COMPATIBLE WITH THE CIRCUIT BOARD	REPLACE IT WITH A COMPATIBLE MODEL.	AUTOMATIC.

2. MAINTENANCE

CODE	FAULT	POSSIBLE CAUSE	SOLUTION	RESET
E98	SUPPLY VOLTAGE	SUPPLY VOLTAGE OFF THE OPERATION RANGE (≤ 160 VOLTS).	CHECK THE POWER SUPPLY NETWORK (THE ERROR DEACTIVATES AUTOMATICALLY AS SOON AS THE SUPPLY VOLTAGE FALLS BACK WITHIN THE REQUESTED LIMITS).	AUTOMATIC.
E99	GENERAL BOARD ERROR INTERNAL	INCORRECT SIGNAL RECOGNITION BY THE MODULATION BOARD MICRO-PROCESSOR.	IF THE MODULATION BOARD DOES NOT RESET THE ERROR AUTOMATICALLY, REPLACE IT.	AUTOMATIC.

2.2.15. ACTIVE FUNCTIONS SIGNALLING CODES

CODE	FUNCTION	DESCRIPTION
F09	<i>D.H.W CIRCUIT ANTI-FREEZE</i>	IF THE OPTIONAL ELECTRICAL RESISTANCES KIT (CODE 50-00106) IS INSTALLED IN THE WATER HEATER, THE FROST PROTECTION SYSTEM ACTIVATES WHEN THE WATER TEMPERATURE GOES BELOW THE VALUE SET AT PARAMETER P11 (SEE CHAPTERS "ACCESSING AND PROGRAMMING THE PARAMETERS" AND "MIAB3113 PARAMETERS TABLE"). THE ELECTRICAL RESISTANCES HEAT THE WATER HEATER PIPES UNTIL A TEMPERATURE 5°C HIGHER THAN THE VALUE SET AT PARAMETER P11 IS REACHED.

2.2.16. GAS TYPE TRANSFORMATION



ATTENTION

Make sure that the gas adduction tube is suitable for the new type of fuel with which the water heater is supplied.

- > loosen the two screws '1' (fig.1) from the fastening bush, and remove the air suction tube;
- > unscrew the tube coupling that connects the gas valve to venturi;
- > unscrew the three fastening screws '2' (fig.1) of the venturi 'V' (fig.1) using a 10 key, as shown in figure 2;
- > remove the two screws '3' (fig.3) and apply pressure on the rear side of venturi 'C' (fig.3);
- > replace the body venturi with the one suitable for the type of supply gas (cod. 30-00207 for methane / cod. 30-00201 for GPL) and make sure the tooth 'D' (fig.3) is adjusted downwards on the aluminium ring nut (see fig.3);
- > remount the components following the demounting operations in reverse making sure that gasket 'G' is re-assembled as shown in fig.1;
- > set the water heater to operate with the new type of gas, changing the value of the parameter P01 'GAS TYPE SELECTION' from the control panel (see chapters 'DIGITECH CS PARAMETERS TABLE' and 'ACCESSING AND PROGRAMMING THE PARAMETERS');
- > adjust the CO₂ combustion value as indicated in chapter 'CO₂ VALUE CHECK AND CALIBRATION'.

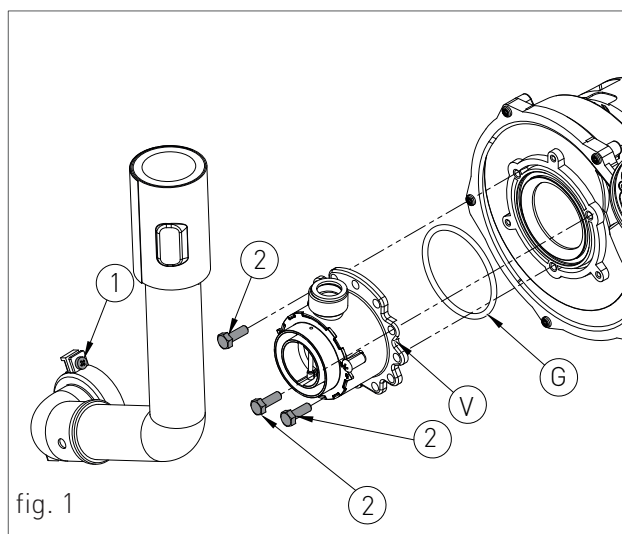

fig. 1

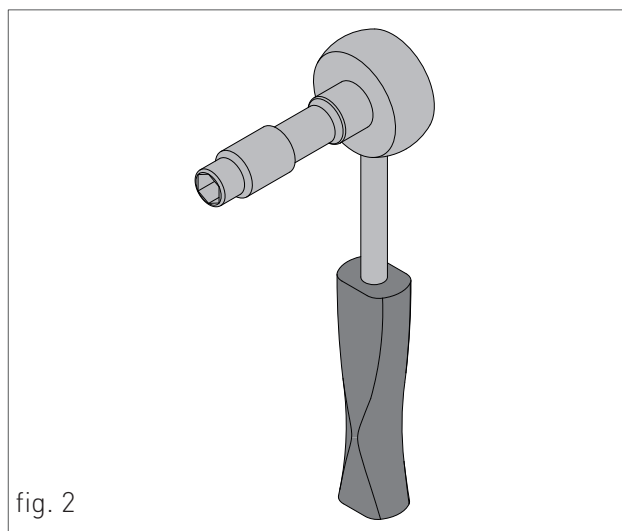

fig. 2

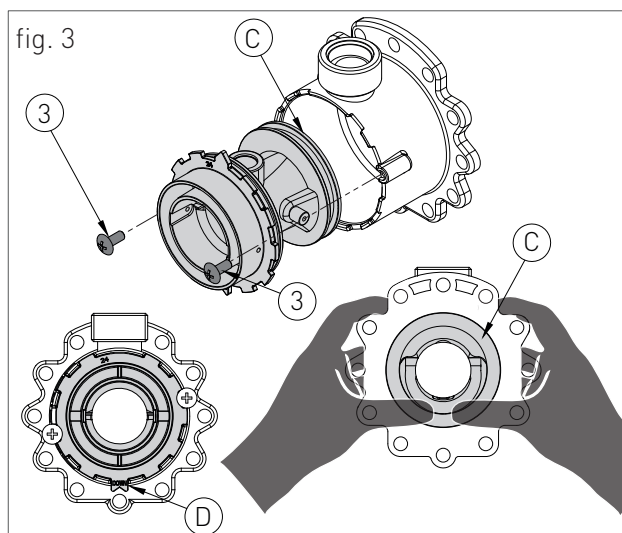

fig. 3

3. USER SECTION

The operations described in this section are addressed to all those who will use the machine. The machine must be used and accessed only by qualified operators that fully read and understood the User section, paying particular attention to the warnings.

3.1. USE

3.1.1. GENERAL USE WARNINGS



WARNING

Before starting the water heater the User must make sure that the First start-up certificate has the stamp of the technical Support Centre proving the testing and the first start-up of the water heater .



WARNING

In order to take advantage of the guarantee provided by the manufacturer, the customer should carefully and exclusively observe the instructions given in the USER section of the manual.



ATTENTION

This machine may be used only for the purpose for which it has been designed: heat water to a temperature below boiling point at atmospheric pressure. Any other use is considered wrong and dangerous. The manufacturer is excluded from any contractual or out of contract responsibility for damage caused to people, animals or property due to incorrect use.



DANGER

The water heater should not be used by persons (including children) with reduced physical, sensory or mental capacities or without suitable knowledge or experience unless they are instructed on the device use or monitored by a person responsible for their safety.



DANGER

DO NOT obstruct the air vents of the location in which the gas device is installed to prevent the formation of toxic explosive mixes.



DANGER

If you sense a gas odour in the location in which the water heater is installed, proceed as follows:

- › DO NOT use electrical switches, the telephone or any other device that might generate electrical discharges or sparks;
- › Immediately open all doors and windows to create an air exchange that can quickly clean the location;
- › Close the gas valves;
- › Request immediate intervention of qualified staff.



DANGER

The use of the electrical power water heater implies respecting some fundamental rules such as:

- › DO NOT touch the device with wet and/or humid parts and/or with bare feet;
- › DO NOT pull the electrical cables;
- › DO NOT leave the device exposed to atmospheric agents (rain, sun, etc.) unless specifically intended;
- › in case of cable damage, turn off the device and contact qualified professional staff to replace it.

3.1.2. CONTROL PANEL

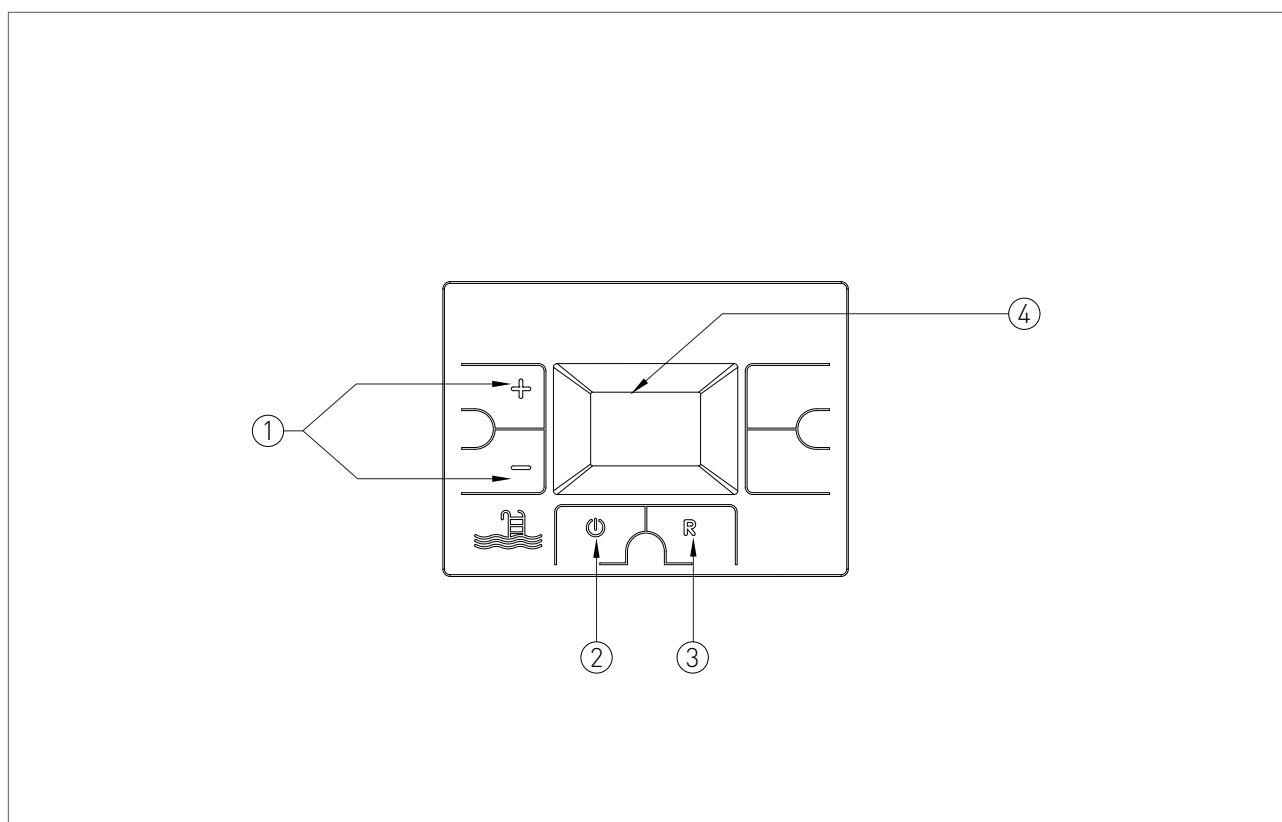
**KEY**

1. DOMESTIC HOT WATER TEMPERATURE ADJUSTMENT KEYS
2. OPERATING MODE SELECTION KEY: ON / OFF
3. RESET KEY: ANOMALY RESET
4. DISPLAY

3.1.3. DISPLAY ICONS

KEY

1. INDICATION OF PARAMETER NUMBER OR DISPLAYED INFO CODE.
2. FLAME PRESENT SIGNALLING.
3. ERROR DISPLAY THAT CAN BE RESET.
4. PARAMETERS PROGRAMMING FUNCTION ACTIVE.
5. OPERATION IN DOMESTIC MODE ENABLED.

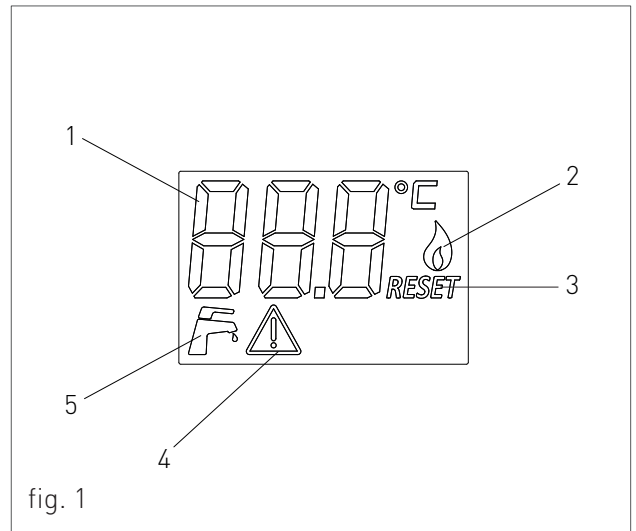

3.1.4. INFO MENU DISPLAY DATA



To view the boiler data from the info menu you just have to press at the same time the keys **R** and **-** of the DHW circuit **51** for 2 seconds. It will be displayed the info code alternated to the associated value. Use keys **+** and **-** of the domestic circuit **51** to scroll through the list of displayed data. To exit display mode press the **R** key.

LIST OF DISPLAYED DATA



INFO CODE	DESCRIPTION
0	FAN SPEED FREQUENCY (IN RPM/30)
1	HOT WATER CAPACITY (IN l/m)
2	FIRMWARE VERSION



3.1.5. START-UP

Before starting the water heater make sure that it is powered and that the gas tap below the water heater is open.

To start the water heater, press the function button  and select the D.H.W. ONLY operating mode. If the symbol  is displayed fixed, it means that the function was activated.

3.1.6. DOMESTIC HOT WATER TEMPERATURE ADJUSTMENT

You can adjust the temperature using keys  and  of the domestic circuit .

- press key  to decrease the temperature.
- press key  to increase the temperature.

The hot domestic water temperature adjustment field ranges from **25 °C to 45 °C**.

3.1.7. OFF MODE

In this mode the water heater no longer meets the D.H.W. requests. The frost protection system remains still active.

To switch the boiler to OFF operating mode, press the function  button. The message OFF indicates that the function is activated.

If the water heater was previously running, it will be turned off and the post-ventilation function will be enabled.

If you have to deactivate the water heater for a long period of time, proceed as follows:

- › contact the Technical support centre that will empty the water system and will cut off the power, water and gas supply.

- › Or ask the installation of the optional electrical resistances kit (see chapter 'INFORMATIONAL NOTE ON ANTI-FREEZE FUNCTION').

3.1.8. INFORMATIONAL NOTE ON ANTI-FREEZE FUNCTION

The water heater can be protected against freezing thanks to the optional electrical resistances kit (code 50-00106).

When the optional electrical resistances kit is installed in the water heater, the D.H.W. frost protection function of the P.C.B. heats the concerned parts when their temperature goes below the minimum pre-set values.



WARNING

This function is available only if:

- › the optional electrical resistances kit is installed;
- › the water heater is powered.

3.1.9. FAULT SIGNALLING CODES

The water heater might signal some faults by displaying a code. Below you have a list of the codes and of the operations to be performed in order to unlock the water heater.

CODE	FAULT	INTERVENTION
E01	FLAME BLOCK	<p>MAKE SURE THAT THE WATER HEATER AND CONTACTOR GAS VALVES ARE OPEN.</p> <hr/> <p>PRESS THE RESET  BUTTON ON THE CONTROL PANEL TO RESET THE FAULT, AS SOON AS THE ERROR CODE DISAPPEARS FROM THE DISPLAY, THE WATER HEATER WILL START AUTOMATICALLY.</p> <hr/> <p>IF THE BLOCK PERSISTS CONTACT THE TECHNICAL SUPPORT CENTRE.</p>
E02	SAFETY THERMOSTAT	CONTACT THE TECHNICAL SUPPORT CENTRE.
E03	FUMES SAFETY THERMOFUSE (102 °C)	CONTACT THE TECHNICAL SUPPORT CENTRE.
E05	INLET PROBE (COLD WATER)	CONTACT THE TECHNICAL SUPPORT CENTRE.
E06	DOMESTIC CIRCUIT PROBE	CONTACT THE TECHNICAL SUPPORT CENTRE.
E16	ELECTRIC FAN	CONTACT THE TECHNICAL SUPPORT CENTRE.
E22	PARAMETERS REQUEST PROGRAMMING	<p>CUT OFF THE POWER SUPPLY FROM THE MAIN SWITCH AND THEN RESTORE IT, AS SOON AS THE ERROR CODE DISAPPEARS, THE WATER HEATER WILL RESTART AUTOMATICALLY.</p> <hr/> <p>IF THE BLOCK PERSISTS CONTACT THE TECHNICAL SUPPORT CENTRE.</p>
E31	REMOTE CONTROLLER INCOMPATIBLE	CONTACT THE TECHNICAL SUPPORT CENTRE.
E98	SUPPLY VOLTAGE	CONTACT THE TECHNICAL SUPPORT CENTRE.
E99	GENERAL INTERNAL BOARD ERROR	<p>CUT OFF THE POWER SUPPLY FROM THE MAIN SWITCH AND THEN RESTORE IT, AS SOON AS THE ERROR CODE DISAPPEARS, THE BOILER WILL RESTART AUTOMATICALLY.</p> <hr/> <p>IF THE BLOCK PERSISTS CONTACT THE TECHNICAL SUPPORT CENTRE.</p>

3.1.10. ACTIVE FUNCTIONS
SIGNALLING CODES

CODE	FUNCTION	INTERVENTION
F09	<i>D.H.W CIRCUIT ANTI-FREEZE FUNCTION ACTIVE</i>	WAIT UNTIL THE OPERATION IS COMPLETED

3.1.11. MAINTENANCE

To ensure proper water heater safety and efficiency, please check the device every year.

An accurate maintenance should improve system management.

3.1.12. COVER CLEANING

Clean the cover of the device using a wet cloth and come neutral soap.



WARNING

DONOT use abrasive or powder detergents as they might damage the plastic cover and control elements.

3.1.13. DISPOSAL

The water heater and all its accessories must be disposed of by differentiating them appropriately according to the recycling regulation in force.



The use of the symbol WEEE (Waste Electrical and Electronic Equipment) indicates that this product can not be dismantled as domestic waste. Proper disposal

of this product helps preventing potentially negative consequences for the environment and person's health.

For more information please visit:

**[www.flexiheatuk.com/product/
swimming-pool-gas-/boilers-
heaters](http://www.flexiheatuk.com/product/swimming-pool-gas-/boilers-heaters)**



Flexiheat UK
Heating and hot water solutions

www.flexiheatuk.com
01202 822221