

Catalogue
[2024]

INERTIA BUFFER TANKS



FLEXIHEAT UK LTD

www.flexiheatuk.com

01202 822221

BUFFER TANKS / BUFFER VESSELS

FOR CLOSED HEATING OR COOLING CIRCUITS

for individual and communal installation and industrial applications.

INERTIA BUFFER TANKS



A close-up photograph of water cascading over a concrete dam into a pool. The water is clear and blue, creating a sense of freshness and purity. The background is a soft, out-of-focus landscape under a clear sky.

WATER IN CLOSED CIRCUITS

HEATING
REFRIGERATION

Proven quality and
maximum storage capacity.

Solutions FOR YOUR COMFORT AND ECONOMY

PHWW



BUFFER TANKS

FOR CLOSED HEATING OR COOLING CIRCUITS

30 to 6000 litres

for individual and communal installation
and industrial applications

INERTIA TANKS

BUFFER TANKS FOR PRIMARY CIRCUITS

SERIES

GEISER INERTIE

domestic range
30 to 1000 litres



MODELS	CAPACITIES (l.)	STEEL MATERIAL	STANDARD HW PRODUCTION TYPE/SYSTEM	OPTIONAL HW PRODUCTION SYSTEM
G-...-I	370 to 1500	S235JR	STORAGE	ELECTRIC HEATING ELEMENT
G-...-IF	30 to 1500	S235JR	STORAGE	ELECTRIC HEATING ELEMENT
GX4-...-I/F	80 to 1000	AISI 304L	STORAGE	ELECTRIC HEATING ELEMENT
G-...-IS	370 to 1500	S235JR	STORAGE / COIL	ELECTRIC HEATING ELEMENT
G-...-IFS	260 to 1500	S235JR	STORAGE / COIL	ELECTRIC HEATING ELEMENT
G-...-L	800 to 1500	S235JR	STORAGE / STRATIFICATION	ELECTRIC HEATING ELEMENT
G-...-LW	800 to 1500	S235JR	COIL / STRATIFICATION	ELECTRIC HEATING ELEMENT

THERMAL INSULATION
ACCESSORIES

MV-...-I	1500 to 5000	S235JR	STORAGE	ELECTRIC HEATING ELEMENTS
MV-...-IB	1500 to 6000	S235JR	STORAGE	ELECTRIC HEATING ELEMENTS
MXV4-...-I	1500 to 6000	AISI 304L	STORAGE	ELECTRIC HEATING ELEMENTS
MXV4-...-IB	1500 to 6000	AISI 304L	STORAGE	ELECTRIC HEATING ELEMENTS
MV-...-IS	1500 to 5000	S235JR	COIL	ELECTRIC HEATING ELEMENT
MV-...-ISB	1500 to 5000	S235JR	COIL	ELECTRIC HEATING ELEMENT
MV-...-L	2000 to 5000	S235JR	STORAGE / STRATIFICATION	ELECTRIC HEATING ELEMENT

THERMAL INSULATION
ACCESSORIES

FINISHES IN ALUMINIUM ALUNOX

INDUSTRIAL CAPACITY INERTIA TANKS: 7000 to 12000 litres



MASTER INERTIE

large capacity
1500 to 6000 litres

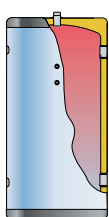

G-I
pag. 10

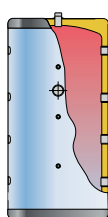

G-I/IF
pag. 10

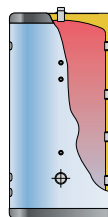

GX4-IF (AISI-304)
page 10

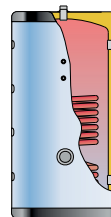

G-IS / G-IFS
pag. 12

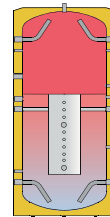



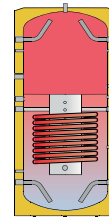



G-L
pag.16



G-LW
pag. 17

APPLICABLE ENERGY SOURCE

INDEX

 HEAT PUMP	 SOLAR COLLECTORS	 GAS/FUEL OIL BOILER	 SOLID FUELS BOILER	 ELECTRIC HEATING ELEMENTS	 SEVERAL COMBINED ENERGY SOURCES	PAGE
•	•	•	•	•	•	10
•	•	•	•	•	•	10
•	•	•	•	•	•	10
•	•	•	•	•	•	12
•	•	•	•	•	•	12
•	•	•	•	•	•	16
•	•	•	•	•	•	17
						20
						21
•	•	•	•	•	•	11
•	•	•	•	•	•	11
•	•	•	•	•	•	11
•	•	•	•	•	•	11
•	•	•	•	•	•	13
•	•	•	•	•	•	13
•	•	•	•	•	•	18
						20
						21
						21
						24

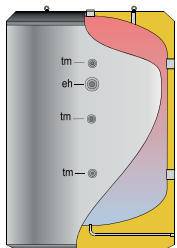

MV-I / MXV4-I (AISI-304)
page 11

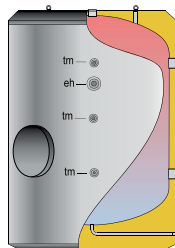

MV-IB / MXV4-IB (AISI-304)
page 11

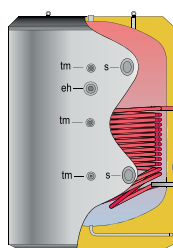

MV-IS / ISB
pag. 13

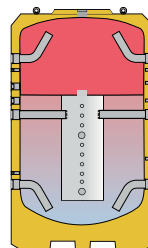

MV-L
pag. 18



INDUSTRIAL CAPACITY
pag. 24



GEISER INERTIA / MASTER INERTIA
energy storage!

*The **GEISER INERTIA** and **MASTER INERTIA** series of buffer tanks are designed for use exclusively in closed heating or cooling circuits. These storage tanks in carbon steel include all of the hydraulic connections required for energy storage or heat inertia installations and, especially for the application of **RENEWABLE ENERGIES** where energy storage is a key factor in the efficient operation of the system.*

APPLICATIONS

GEISER INERTIA (50 to 1500 litres):

- (Individual or battery installation)
- Installations with solar energy
- Installations with biomass boilers
- Installations with heat pumps
- Combined energy storage installations
- Cooling installations

MASTER INERTIA (1.500 to 6000 litres):

- (Individual or battery installation)
- Energy storage and distribution facilities
- Centralized thermal solar energy systems
- Centralized systems with heat pump
- Centralized systems with biomass boiler
- Centralized instant DHW production systems
- Centralized combined energy storage systems
- Cooling installations



ENERGY BUFFER TANKS

for installations that
require correct energy
management, especially for
systems that use
renewable energy
sources such as:

BIOMASS, HEAT PUMP or SOLAR ENERGY





GEISER / MASTER INERTIA

Inertia buffer tanks, energy storage!

Inertia buffer tanks for closed heating or cooling circuits that act as the installation energy regulator.

*Models with or without internal exchanger and models with own heat stratification system complete our range of **GEISER/MASTER INERTIA**, from 30 to 6000 litres storage capacity.*

PRIMARY BUFFER TANKS Energy buffer tanks from **30** to **6000** litres capacity, for closed heating or cooling circuits.

For installations that require correct energy management, especially for systems that use renewable energy sources such as: **BIOMASS, HEAT PUMP or SOLAR ENERGY.**

Designed to provide an extraordinary storage capacity that translates directly into real savings. The overdimensioned, rigid, mould-injected PU thermal insulation maintains the DHW storage temperature over long periods of time without requiring any additional energy input. This means less start-ups and adjustments of external energy sources, with less energy consumption and a more economical cost.

MODELS WITH COILS: Versions with heating coils as the intermediate thermal exchange system, for systems without their own heat exchanger.

Ready for installation with electric heating elements to provide back-up electric heating.



BUFFER TANKS FOR PRIMARY CIRCUITS GEISER / MASTER INERTIA - **STORAGE**

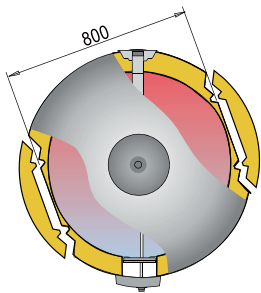
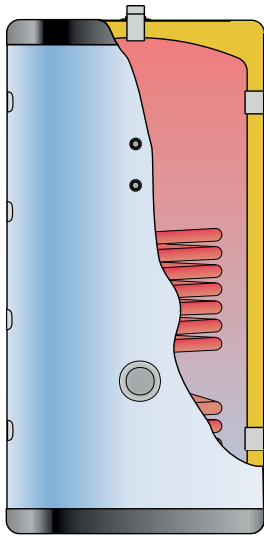

Detail of pre-cut insulation on 800 and 1000 litre tanks to pass through 800 mm wide doors.

MODELS WITH THERMAL STRATIFICATION SYSTEM: Versions that incorporate thermal stratification for perfect energy management of the installation.

MAXIMUM STORAGE CAPACITY: Extra thick, rigid, PU mould-injected insulation that minimizes heat losses of stored DHW (see HEAT INSULATION chapter, page: 20).

Lapesa buffer tanks have minimal heat losses and for this reason are considered to be one of the products with the greatest storage capacity on the market.

EASY TO INSTALL AND MAINTAIN: GEISER INERTIA 800 and 1000 litre models are designed with a detachable insulation system on the two opposite sides of the tank to allow them to pass through 800 mm wide accesses.

The MASTER INERTIA "IB" and "ISB" models include a ND400 side manhole to access the interior of the tank to carry out inspection, cleaning and maintenance tasks.

EASY TO HANDLE AND TRANSPORT: Our "MASTER INERTIA" buffer tanks are designed for easy handling and transport to the place of installation.

They have an integrated system for handling and transporting by forklift truck, which facilitates handling operations enormously, as there is no need to palletize the product which, given its weight and size, would make handling difficult.

The tanks are also equipped with lifting eyebolts on the top part so that if they have to be placed in a high area they can be lifted with an overhead hoist.



FEATURES COMMON TO ALL "GEISER INERTIA/MASTER INERTIA" MODELS:

- **Carbon steel** inertia buffer tank.
- GEISER INERTIA capacities: **30, 50, 80, 140, 200, 240, 370, 600, 800, 1000 and 1500 litres.**
- MASTER INERTIA capacities: **1500, 2000, 2500, 3000, 3500, 4000, 5000 and 6000 litres.**
- Maximum working pressure of buffer tank: **6 bar**
- Maximum working pressure, coil (models "IS" and "IFS"): **25 bar**
- Maximum working temperature of buffer tank: **110 °C**
- Maximum working temperature, coil (models "IS" and "IFS"): **200 °C**
- Thermal insulation: **Rigid, mould-injected PU** (CFC/HCFC-free, 0.025 W/m²K)
- Tanks for VERTICAL installation on floor (option of HORIZONTAL position - please consult us)

BUFFER TANKS FOR PRIMARY CIRCUITS GEISER INERTIA - STORAGE

GEISER INERTIA "I / IF"

INERTIA buffer tanks from **30 to 1500** litres capacity, for closed heating or cooling circuits.
30, 50 and 80 litre models - for wall-mounting.

From 140 litre model onwards - for vertical installation on floor.

Ready for a backup electric immersion element to be fitted (up to 1000 litre model).

The 800 and 1000 litre capacity tanks include an insulation system that allows them to pass through 800 mm wide doors. Standard finish with RAL 5015 padded external lining and RAL 7021 grey cover (for model G-30-IF with white lining). For models of 1500 litre of capacity, set grey padded external lining RAL 7042 and black cover, supplied separately.

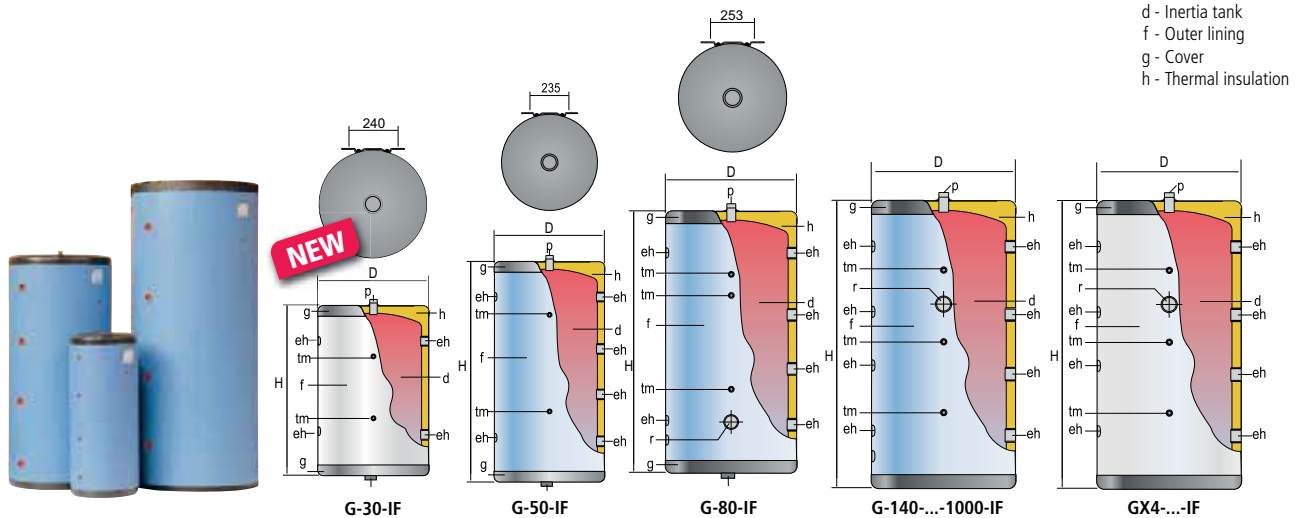

GENERAL CHARACTERISTICS							G-370-I	G-600-I	G-800-I	G-1000-I	G-1500-I	
CARBON STEEL	Capacity	l.						370	600	800	1000	1500
	D: external diameter	mm.						620	770	950	950	1160
	H: overall height	mm.						1725	1730	1840	2250	2320
	eh: side connection	" GAS/F						2	3	3	3	3
	p: upper connection	" GAS/M						1	1	1	1	1
tm: probe tube connection for sensors	" GAS/F						1/2	1/2	1/2	1/2	1/2	
Empty weight (approx.)	Kg						68	95	174	205	300	
GENERAL CHARACTERISTICS		G-30-IF	G-50-IF	G-80-IF	G-140-IF	G-200-IF	G-260-IF	G-370-IF	G-600-IF	G-800-IF	G-1000-IF	
CARBON STEEL	Capacity	l.	30	50	80	140	200	260	370	600	800	1000
	D: external diameter	mm.	380	380	480	480	620	620	620	770	950	950
	H: overall height	mm.	545	835	749	1155	985	1240	1725	1730	1840	2250
	eh: side connection	" GAS/F	1 1/4	1 1/4	1 1/4	1 1/4	1 1/2	1 1/2	1 1/2	1 1/2	1 1/2	1 1/2
	p: upper connection	" GAS	1/2 H	1/2 H	1/2 H	1M	1M	1M	1M	1M	1M	1M
	tm: probe tube connection for sensors	" GAS/F	1/2	1/2	1/2	1/2	1/2	1/2	1/2	1/2	1/2	1/2
R: electric element connection	" GAS/F	-	-	2	2	2	2	2	2	2	2	
Empty weight (approx.)	Kg	13	20	30	35	44	52	68	95	174	205	
GENERAL CHARACTERISTICS STAINLESS STEEL AISI 304		GX4-80-IF	GX4-140-IF	GX4-200-IF	GX4-260-IF	GX4-370-IF	GX4-500-IF	GX4-800-IF	GX4-1000-IF			
STAINLESS STEEL	Capacity	l.	80	140	200	260	370	500	800	1000		
	D: external diameter	mm.	480	480	620	620	620	770	950	950		
	H: overall height	mm.	749	1155	985	1240	1725	1730	1840	2250		
	eh: side connection	" GAS/F	1 1/4	1 1/4	1 1/2	1 1/2	1 1/2	1 1/2	1 1/2	1 1/2		
	p: upper connection	" GAS	1 H	1M	1M	1M	1M	1M	1M	1M		
	tm: probe tube connection for sensors	" GAS/F	1/2	1/2	1/2	1/2	1/2	1/2	1/2	1/2		
R: electric element connection	" GAS/F	2	2	2	2	2	2	2	2			
Empty weight (approx.)	Kg	22	25	32	38	50	70	128	150			

BUFFER TANKS FOR PRIMARY CIRCUITS

MASTER INERTIA - STORAGE

MASTER INERTIA "I / IB"

INERTIA buffer tanks from **1500** to **6000** litres capacity, for closed heating or cooling circuits.

Ready to be fitted with a backup electric immersion element.

Thermally insulated with rigid, mould-injected, 80 mm-thick, PU polyurethane foam, with insulating piece in same material on the ND400 side manhole.

Optional supply of PVC padded external lining and set of trims or ALUNOX aluminium sheet lining (see ACCESSORIES chapter, page: 21).

IB MODELS: With side ND400 manhole to access inside the storage tank for inspection, cleaning and maintenance tasks.

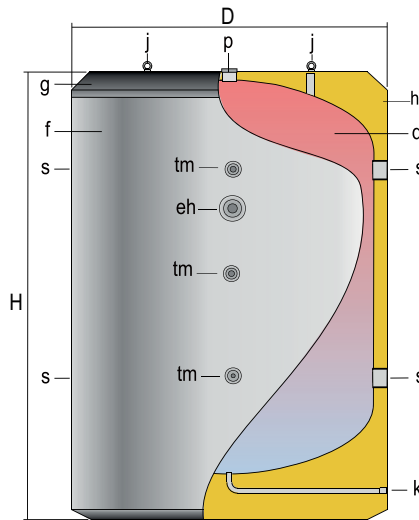

- d - Buffer tank
- f - Outer lining
- g - Top cover
- h - Thermal insulation
- j - Lifting eyebolts



CARBON STEEL

GENERAL CHARACTERISTICS		MV-1500 I/IB	MV-2000 I/IB	MV-2500 I/IB	MV-3000 I/IB	MV-3500 I/IB	MV-4000 I/IB	MV-5000 I/IB	MV-6000 IB
Capacity	l.	1500	2000	2500	3000	3500	4000	5000	6000
D: external diameter	mm.	1360	1360	1660	1660	1660	1910	1910	1910
H: overall height	mm.	1830	2280	2015	2305	2580	2310	2710	3210
Diagonal	mm.	2281	2655	2611	2841	3068	2998	3316	3735
s: side connection	" GAS/F	4	4	4	4	4	4	4	4
eh: electric element connection	" GAS/F	2	2	2	2	2	2	2	2
p: upper connection	" GAS/F	2	2	2	2	2	2	2	2
k: drain connection	" GAS/M	1 1/2	1 1/2	1 1/2	1 1/2	1 1/2	1 1/2	1 1/2	2
tm: probe tube connection for sensors	" GAS/F	1/2	1/2	1/2	1/2	1/2	1/2	1/2	1/2
Empty weight (approx.) "I / IB"	Kg	273 / 298	353 / 378	503 / 528	540 / 565	576 / 601	893 / 918	970 / 995	1090
Side hole (only in IB model)		DN400	DN400	DN400	DN400	DN400	DN400	DN400	DN400

STAINLESS STEEL

GENERAL CHARACTERISTICS STAINLESS STEEL AISI 304		MXV4-1500 I/IB	MXV4-2000 I/IB	MXV4-2500 I/IB	MXV4-3000 I/IB	MXV4-3500 I/IB	MXV4-4000 I/IB	MXV4-5000 I/IB	MXV4-6000 IB
Capacity	l.	1500	2000	2500	3000	3500	4000	5000	6000
D: external diameter	mm.	1360	1360	1660	1660	1660	1910	1910	1910
H: overall height	mm.	1830	2280	2015	2305	2580	2310	2710	3210
Diagonal	mm.	2281	2655	2611	2841	3068	2998	3316	3735
s: side connection	" GAS/F	4	4	4	4	4	4	4	4
eh: electric element connection	" GAS/F	2	2	2	2	2	2	2	2
p: upper connection	" GAS/F	2	2	2	2	2	2	2	2
k: drain connection	" GAS/M	1	1	1	1	1	1	1	1
tm: probe tube connection for sensors	" GAS/F	1/2	1/2	1/2	1/2	1/2	1/2	1/2	1/2
Empty weight (approx.) "I / IB"	Kg	273 / 298	353 / 378	503 / 528	540 / 565	576 / 601	893 / 918	970 / 995	1090
Side hole (only in IB model)		DN400	DN400	DN400	DN400	DN400	DN400	DN400	DN400

Note: The 6000 litre model includes support legs.

BUFFER TANKS FOR PRIMARY CIRCUITS

GEISER INERTIA - COIL

GEISER INERTIA "IS / IFS"

INERTIA buffer tanks, **260** to **1500** litre capacity, for closed heating or cooling circuits, with integrated intermediate heating **COIL**.

From 260 litre model onwards - for vertical installation on floor.

Ready to be fitted with a backup electric immersion element.

Up to 1000 litre model, standard finish with RAL 5015 blue padded external lining and RAL 7021 grey cover.

The 800 and 1000 litre capacity tanks include an insulation system that allows them to pass through 800 mm wide doors. External lining is optional for the 1500 litre model and is supplied separately (RAL 7042 grey external lining and black cover).

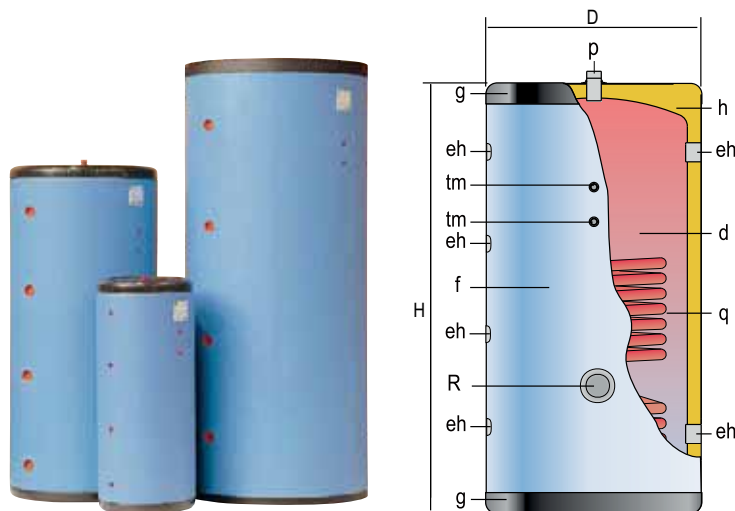

d - Buffer tank
f - Outer lining
g - Cover
h - Thermal insulation
q - Heating coil

GENERAL CHARACTERISTICS		G-370-IS	G-600-IS	G-800-IS	G-1000-IS	G-1500-IS
DHW capacity	l.	370	600	800	1000	1500
D: external diameter	mm.	620	770	950	950	1160
H: overall height	mm.	1725	1730	1840	2250	2320
eh: side connection	" GAS/F	2	3	3	3	3
p: upper connection	" GAS	1M	1M	1M	1M	1M
tm: probe tube connection for sensors	" GAS/F	1/2	1/2	1/2	1/2	1/2
R: electric element connection	" GAS/F	2	2	2	2	2
Heating coil surface	m ²	1,32	1,83	2,70	2,70	3,00
Empty weight (approx.)	Kg	86	123	199	231	339

GENERAL CHARACTERISTICS		G-260-IFS	G-370-IFS	G-600-IFS	G-800-IFS	G-1000-IFS	G-1500-IFS
DHW capacity	l.	260	370	600	800	1000	1500
D: external diameter	mm.	620	620	770	950	950	1160
H: overall height	mm.	1240	1725	1730	1840	2250	2320
eh: side connection	" GAS/F	1 1/2	1 1/2	1 1/2	1 1/2	1 1/2	1 1/2
p: upper connection	" GAS	1M	1M	1M	1M	1M	1M
tm: probe tube connection for sensors	" GAS/F	1/2	1/2	1/2	1/2	1/2	1/2
R: electric element connection	" GAS/F	2	2	2	2	2	2
Heating coil surface	m ²	1,32	1,32	1,83	2,70	2,70	3,00
Empty weight (approx.)	Kg	70	86	123	199	231	339

BUFFER TANKS FOR PRIMARY CIRCUITS

MASTER INERTIA - COIL

MASTER INERTIA "IS / ISB"

INERTIA buffer tanks, **1500 to 5000** litre capacity, for closed heating or cooling circuits, with integrated intermediate heating **COIL**.

Ready to be fitted with an electric immersion element for backup heating.

Thermally insulated with rigid, mould-injected, 80 mm-thick, PU polyurethane foam. Models ISB, with insulating piece in same material on the ND400 side manhole.

With side ND400 manhole to access the interior of the storage tank for inspection, cleaning and maintenance tasks.

Optional supply of PVC padded external lining and set of trims or ALUNOX aluminium sheet lining (see ACCESSORIES chapter, page: 21).

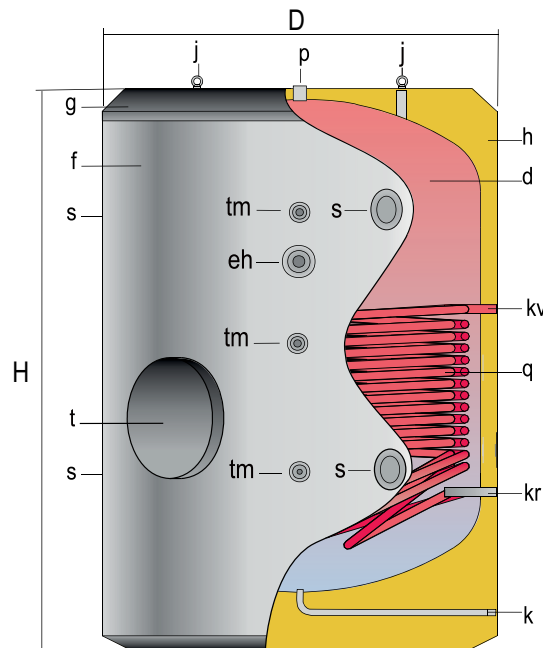

MV-1500-...5000-ISB

- d - Buffer tank
- f - Outer lining
- g - Top cover
- h - Thermal insulation
- j - Lifting eyes
- q - Coil
- t - Manhole ND400



GENERAL CHARACTERISTICS		MV-1500-IS	MV-2000-IS	MV-2500-IS	MV-3000-IS	MV-3500-IS	MV-4000-IS	MV-5000-IS
Capacity	l.	1500	2000	2500	3000	3500	4000	5000
D: external diameter	mm.	1360	1360	1660	1660	1660	1910	1910
H: overall height	mm.	1830	2280	2015	2305	2580	2310	2710
Diagonal	mm.	2281	2655	2611	2841	3068	2998	3316
s: side connection	" GAS/F	4	4	4	4	4	4	4
eh: electric element connectio	" GAS/F	2	2	2	2	2	2	2
p: upper connectionr	" GAS/F	2	2	2	2	2	2	2
k: drain connection	" GAS/M	1 1/2	1 1/2	1 1/2	1 1/2	1 1/2	1 1/2	1 1/2
tm: probe tube connection for sensors	" GAS/F	1/2	1/2	1/2	1/2	1/2	1/2	1/2
kv, kr: coil connections	" GAS/F	1	1	1	1	1	1	1
Heating coil surface	m ²	3,1	3,1	5,7	5,7	6,1	6,1	6,1
Empty weight (approx.) "IS / ISB"	Kg	344 / 369	388 / 423	565 / 590	601 / 626	640 / 665	953 / 978	1030 / 1055
Side hole (models "ISB")	DN	ND400	ND400	ND400	ND400	ND400	ND400	ND400



GEISER/MASTER INERTIA - STORAGE

INERTIA BUFFER TANKS with THERMAL STRATIFICATION energy management!

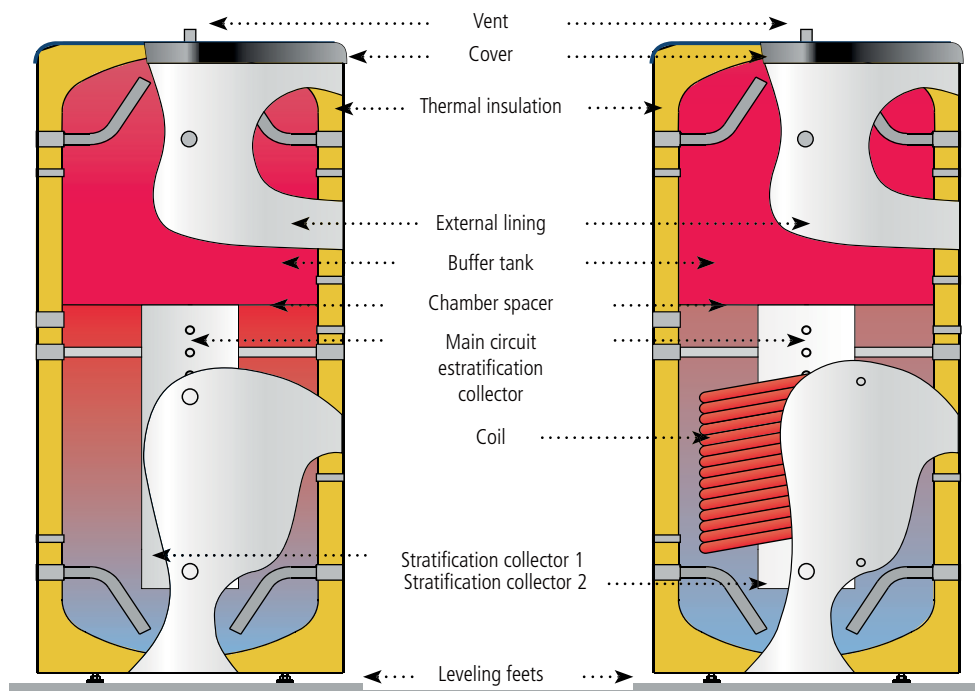

PRIMARY CIRCUIT BUFFER TANKS Energy buffer tanks from **800** to **5000** litres capacity, for closed heating circuits, with integrated **THERMAL STRATIFICATION** system.

For installations that require correct energy management, especially for systems that use renewable energy sources such as: **BIOMASS, HEAT PUMP or SOLAR ENERGY**, or several simultaneously combined energy sources.

Models with coil (LW) as the intermediate heat exchange system.

Designed to provide an extraordinary storage capacity that translates directly into real savings.

The overdimensioned, rigid, mould-injected PU thermal insulation maintains the DHW storage temperature over long periods of time without requiring any additional energy input. This means less start-ups and adjustments of external energy sources, with less energy consumption and a more economical cost.

BUFFER TANKS FOR PRIMARY CIRCUITS

THERMAL STRATIFICATION SYSTEM: Integrated thermal stratification system to install up to three different energy sources simultaneously. Three separate stratification collectors take the hot water returns to the corresponding temperature levels inside the buffer tank.

MULTIFUNCTIONAL: Stratification allows different water temperature levels to be used directly for different purposes. The top zone of the tank is kept at the maximum temperature for instant domestic hot water production or to heat radiators, whilst at the same time the water at a lower temperature can be used for underfloor heating systems.

MAXIMUM STORAGE CAPACITY: Extra thick, rigid, PU mould-injected insulation that minimizes heat losses of stored DHW (see HEAT INSULATION chapter, page: 20).

Lapesa buffer tanks have minimal heat losses and for this reason are considered to be one of the products with the greatest storage capacity on the market.

EASY TO HANDLE AND TRANSPORT: Our "MASTER INERTIA" buffer tanks are designed for easy handling and transport to the place of installation.

They have an integrated system for handling and transporting by forklift truck, which facilitates handling operations enormously, as there is no need to palletize the product which, given its weight and size, would make handling difficult. The tanks are also equipped with lifting eyebolts on the top part so that if they have to be placed in a high area they can be lifted with an overhead hoist. The 800 and 1000 litre models are designed with a detachable insulation system on the two opposite sides of the tank to allow them to pass through 800 mm wide accesses.



Thermal stratification of water stored in inertia buffer tanks allows correct management of energy, taking maximum advantage of it for each specific case and at the lowest economic cost!



FEATURES COMMON TO ALL MODELS:

"GEISER INERTIA / MASTER INERTIA STRATIFICATION":

- **Carbon steel** inertia buffer tanks.
- GEISER INERTIA capacities: **800, 1000 and 1500 litres.**
- MASTER INERTIA capacities: **2000, 2500, 3000, 3500, 4000 and 5000 litres.**
- Maximum working pressure of buffer tank: **6 bar**
- Maximum working pressure, coil ("LW" models): **25 bar**
- Maximum working temperature of buffer tank: **110 °C**
- Maximum working temperature, coil ("LW" models): **200 °C**
- Thermal insulation: **Rigid, mould-injected PU** (CFC/HCFC-free, 0.025 W/m²K)
- Tanks for **VERTICAL** installation on floor.

BUFFER TANKS FOR PRIMARY CIRCUITS GEISER INERTIA - STRATIFICATION

GEISER INERTIA "L"

INERTIA buffer tanks from **800** to **1500** litres capacity, for closed heating circuits, with integrated **THERMAL STRATIFICATION** system.

Tanks for VERTICAL installation on floor.

Up to 1000 litre model, standard finish with RAL 5015 blue padded external lining and RAL 7021 grey cover.

The 800 and 1000 litre capacity tanks include an insulation system that allows them to pass through 800 mm wide doors. Optional supply of aluminium sheet lining ALUNOX (see chapter ACCESSORIES, page: 21).

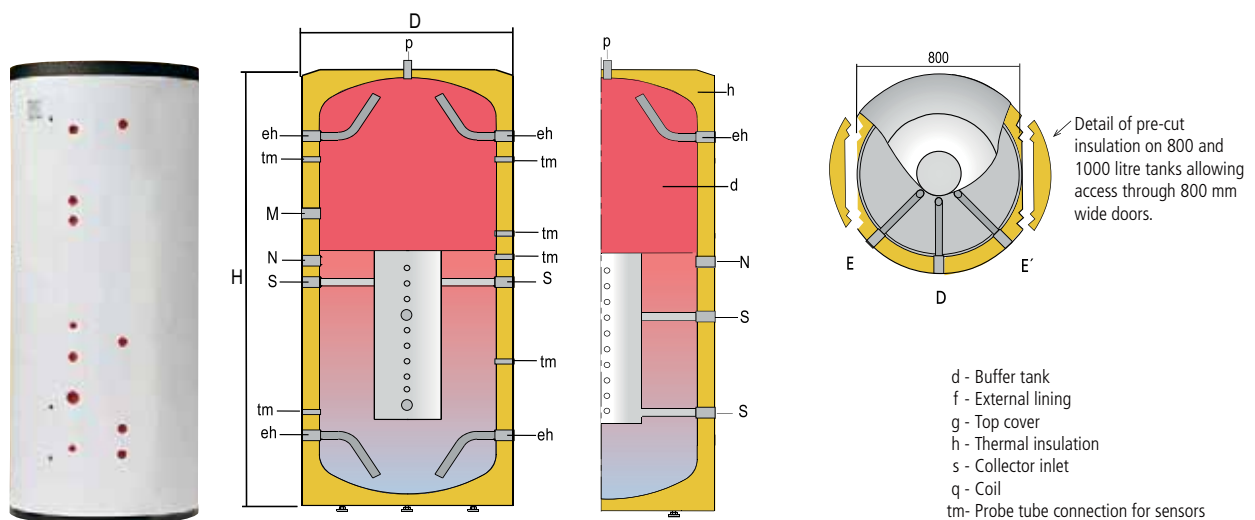

GENERAL CHARACTERISTICS		G-800-L	G-1000-L	G-1500-L
Capacity	l.	800	1000	1500
D: external diameter	mm.	950	950	1160
H: overall height	mm.	1840	2250	2320
eh: side connection	" GAS/F	1 1/2	1 1/2	1 1/2
R: side connection	" GAS/F	2	2	2
N: side connection	" GAS/F	1 1/2	1 1/2	1 1/2
p: upper connection	" GAS/F	3/4	3/4	3/4
tm: probe tube connection for sensors	" GAS/F	1/2	1/2	1/2
S: collector connection	" GAS/F	1 1/2	1 1/2	1 1/2
Empty weight (approx.)	Kg	175	200	260

BUFFER TANKS FOR PRIMARY CIRCUITS

GEISER INERTIA - STRATIFICATION

GEISER INERTIA "LW"

INERTIA buffer tanks from **800** to **1500** litres capacity, for closed heating circuits, with integrated **THERMAL STRATIFICATION** system and **SOLAR COIL**.

Tanks for VERTICAL installation on floor.

Up to 1000 litre model, standard finish with RAL 5015 blue padded external lining and RAL 7021 grey cover.

The 800 and 1000 litre capacity tanks include an insulation system that allows them to pass through 800 mm wide doors. Optional supply of aluminium sheet lining ALUNOX (see chapter ACCESSORIES, page: 21).

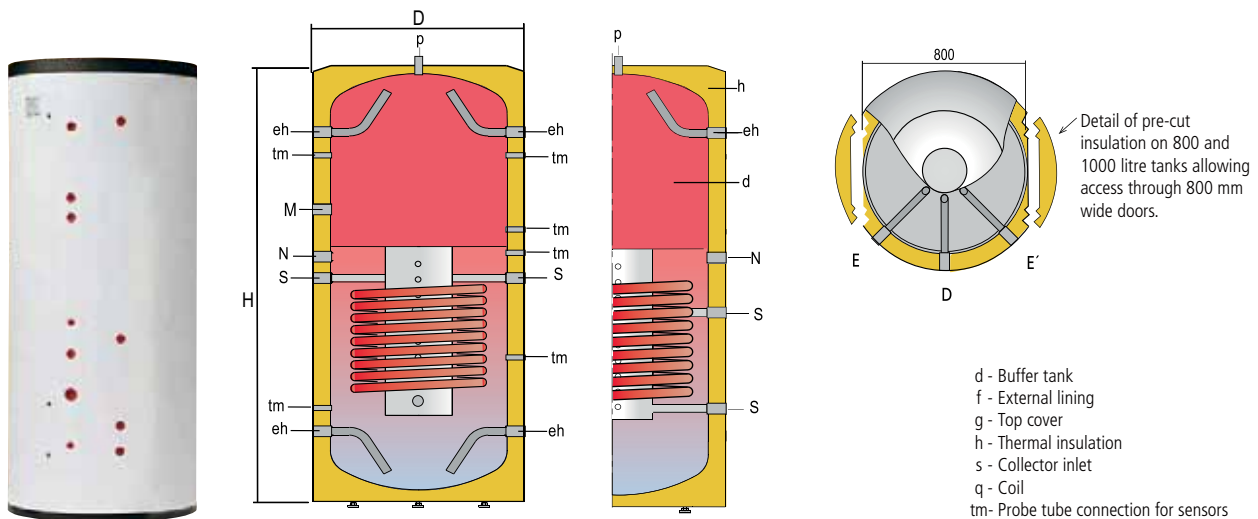

GENERAL CHARACTERISTICS		G-800-LW	G-1000-LW	G-1500-LW
Capacity	l.	800	1000	1500
D: external diameter	mm.	950	950	1160
H: overall height	mm.	1840	2250	2320
eh: side connection	" GAS/F	1 1/2	1 1/2	1 1/2
R: side connection	" GAS/F	2	2	2
N: side connection	" GAS/F	1 1/2	1 1/2	1 1/2
p: upper connection	" GAS/F	3/4	3/4	3/4
tm: probe tube connection for sensors	" GAS/F	1/2	1/2	1/2
S: collector connection	" GAS/F	1 1/2	1 1/2	1 1/2
sv, sr: coil connections	" GAS/F	1	1	1
Empty weight (approx.)	Kg	245	295	365

BUFFER TANKS FOR PRIMARY CIRCUITS MASTER INERTIA - STRATIFICATION

MASTER INERTIA "L"

INERTIA buffer tanks from **2000** to **5000** litres capacity, for closed heating circuits, with integrated **THERMAL STRATIFICATION** system.

Thermally insulated with rigid, mould-injected, 80 mm-thick, PU polyurethane foam.

Optional supply of PVC padded external lining and set of trims or ALUNOX aluminium sheet lining (see ACCESSORIES chapter, page: 21).

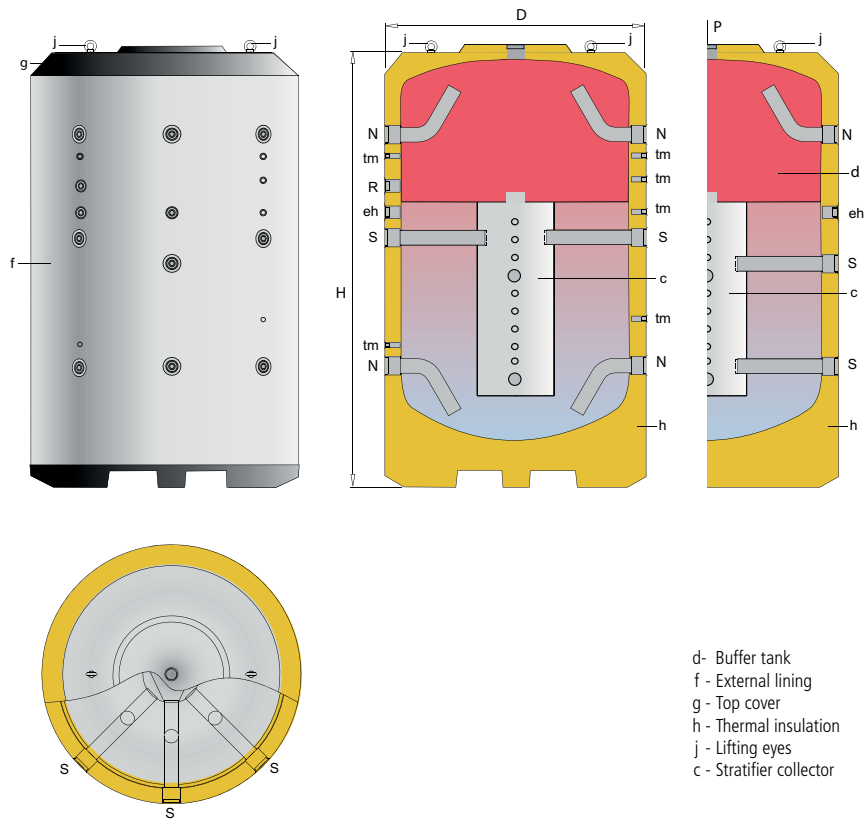

GENERAL CHARACTERISTICS		MV-2000-L	MV-3000-L	MV-4000-L	MV-5000-L
DHW capacity	l.	2000	3000	4000	5000
D: external diameter	mm.	1360	1660	1910	1910
H: overall height	mm.	2280	2305	2310	2710
Diagonal	mm.	2655	2841	2998	3316
eh: side connection	" GAS/F	2	2	2	2
R: side connection	" GAS/F	2	2	2	2
N: side connection	" GAS/F	3	3	3	3
p: upper connection	" GAS/F	2	2	2	2
tm: probe tube connection for sensors	" GAS/F	1/2	1/2	1/2	1/2
S: collector connection	" GAS/F	3	3	3	3
Empty weight (approx.)	Kg	428	616	965	1080

BUFFER TANKS FOR PRIMARY CIRCUITS

Thermal camera images comparing an "L" buffer tank with thermal stratification and a normal inertia model. Independent tests.

Inertia buffer tank (L) WITH integrated thermal stratification

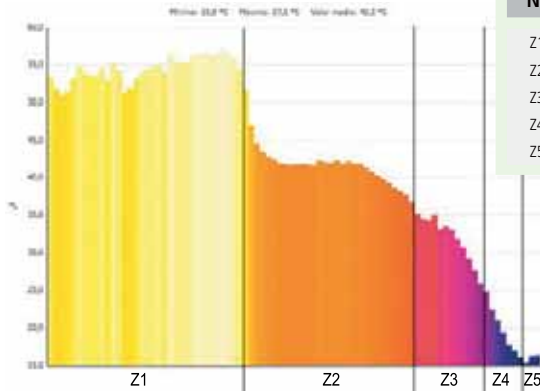
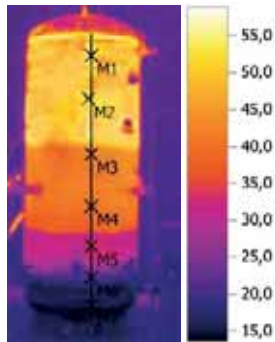
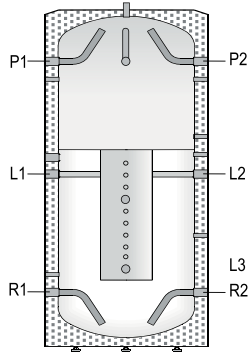

N°	Temp. (°C)	%
Z1	60,0	39
Z2	45,0	33
Z3	35,0	15
Z4	25,0	7
Z5	20,0	6

- Input of water to L2 tank: 40 °C
- Extraction of water from R1 tank: 15 °C
- Continuous flow during test: 500 l/h
- Volume of water during test: 140 litres

Inertia buffer tank WITHOUT integrated thermal stratification

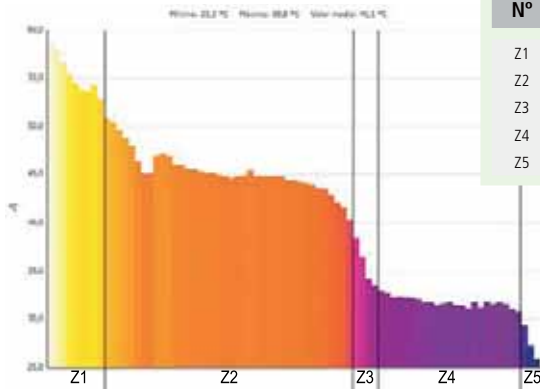
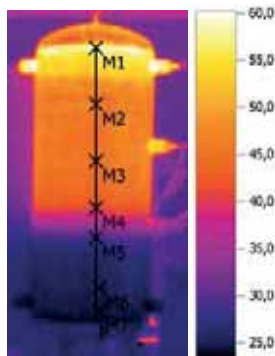
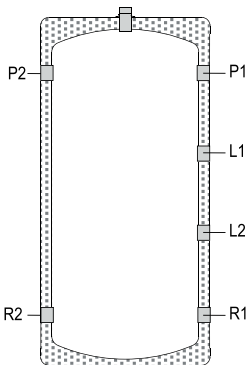

N°	Temp. (°C)	%
Z1	60,0	11
Z2	45,0	50
Z3	35,0	6
Z4	25,0	28
Z5	20,0	6

- Input of water to L2 tank: 40°C
- Extraction of water from R1 tank: 15°C
- Continuous flow during test: 500 l/h
- Volume of water during test: 140 litres

BUFFERING ENERGY CENTER (L)

Connection to DHW production system through plate heat exchanger or DHW tank.

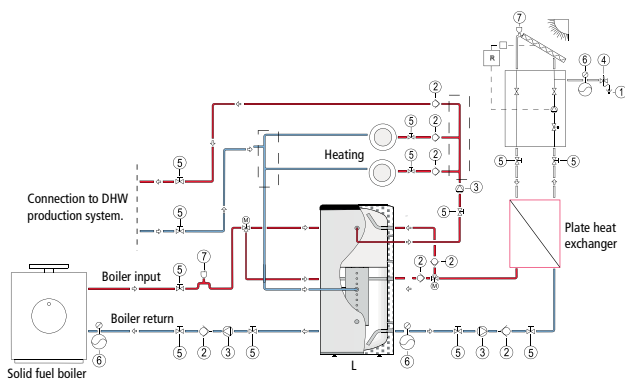

- 1 - Drain
- 2 - Non-return valve
- 3 - Pump
- 4 - Safety valve
- 5 - Shut-off valve
- 6 - Expansion vessel
- 7 - Vent

BUFFERING ENERGY CENTER (LW)

Connection to DHW production system through plate heat exchanger or DHW tank.

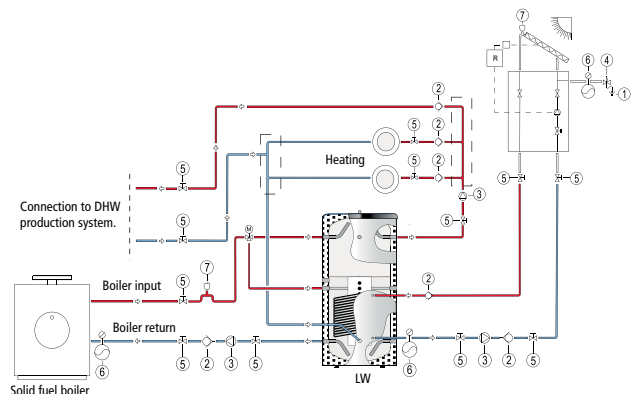

- 1 - Drain
- 2 - Non-return valve
- 3 - Pump
- 4 - Safety valve
- 5 - Shut-off valve
- 6 - Expansion vessel
- 7 - Vent

THERMAL INSULATION - INERTIA



The "**GEISER INERTIA AND MASTER INERTIA**" series of tanks are thermally insulated at the factory by direct mould-injection with CFC-free and HCFC-free PU material. This system guarantees a perfectly regular insulation thickness with optimum material density. The thicknesses indicated in the table refer to the circular tank body, but the insulation is much thicker on the top part (up to four times greater). Because the top zone of the tank has better thermal protection, heat losses are much lower than those specified by the most stringent regulations, such as the DIN 4753/8 standard.

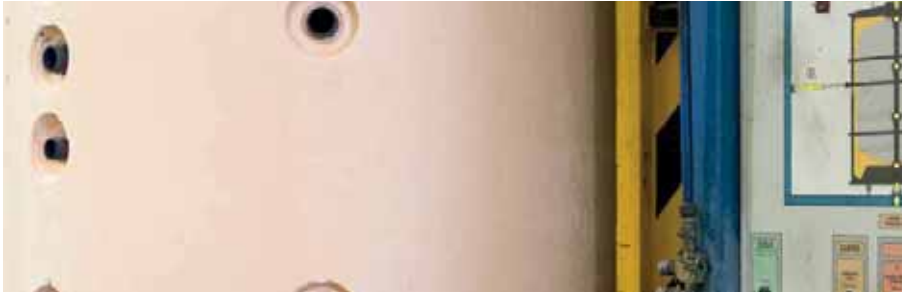

Rigid, mould-injected PU insulating material.



- *Minimal heat loss!*
- *For hot and cold water!*
- *No condensation on tank body!*
- *Compact block, no joints!*

TABLE OF THERMAL INSULATION: GEISER INERTIA / MASTER INERTIA SERIES

Serie	Tank model	Thermal insulation k= 0,025 W/m °K	Insulation thickness PU (mm.)	Static heat losses EN 12897 (W)	ErP  (EU 812/2013)	Minimum thickness of equivalent insulation with other insulating materials(mm)		
						Flexible polyurethane foam* k= 0,040 W/m °K	Rockwool* k= 0,034 - 0,042 W/m °K	Fiberglass* k= 0,035 - 0,046 W/m °K
GEISER INERTIA	G-50-IF	PU	40	37	B	65	55 - 70	55 - 75
GEISER INERTIA	G-80-IF and GX4-80-IF	PU	40	45	B	65	55 - 70	55 - 75
GEISER INERTIA	G-140-IF and GX4-140-IF	PU	40	60	C	65	55 - 70	55 - 75
GEISER INERTIA	G-200-IF and GX4200-IF	PU	40	60	B	65	55 - 70	55 - 75
GEISER INERTIA	G-260-IF/IFS and GX4-260-IF	PU	40	83	C	65	55 - 70	55 - 75
GEISER INERTIA	G-370-IF/IFS and GX4-370-IF	PU	40	85	C	65	55 - 70	55 - 75
GEISER INERTIA	GX4-500-IF	PU	60	81	B	65	55 - 70	55 - 75
GEISER INERTIA	G-600-IF/IFS	PU	40	95	C	65	55 - 70	55 - 75
GEISER INERTIA	G-800-IF/IFS/L*	PU	80	99/*87	C/*B	130	110 - 140	115 - 160
GEISER INERTIA	GX4-800-IF	PU	80	99	C	130	110 - 140	115 - 160
GEISER INERTIA	G-1000-IF/IFS/LW	PU	80	114	C	130	110 - 140	115 - 160
GEISER INERTIA	GX4-1000-IF	PU	80	114	C	130	110 - 140	115 - 160
GEISER INERTIA	G-1500-IF/IFS/LW	PU	80	156	C	130	110 - 140	115 - 160
MASTER INERTIA	MV-1500-IB*/ISB*/LW	PU	80	145/*154	C	130	110 - 140	115 - 155
MASTER INERTIA	MV-2000-IB*/ISB*/LW	PU	80	164/*174	C	130	110 - 140	115 - 155
MASTER INERTIA	MV-2500-IB*/ISB*/LW	PU	80	183/*194	C	130	110 - 140	115 - 155
MASTER INERTIA	MV-3000-IB*/ISB*/LW	PU	80	203/*215	C	130	110 - 140	115 - 155
MASTER INERTIA	MV-3500-IB*/ISB*/LW	PU	80	218/*232	C	130	110 - 140	115 - 155
MASTER INERTIA	MV-4000-IB*/ISB*/LW	PU	80	231/*245	C	130	110 - 140	115 - 155
MASTER INERTIA	MV-5000-IB*/ISB*/LW	PU	80	250/*265	C	130	110 - 140	115 - 155
MASTER INERTIA	MV-6000-IB	PU	80	250/*280	C	130	110 - 140	115 - 155

(*) Detachable insulation systems can lose up to 25% of the insulating capacity overall, so that in that case the insulation thickness will increased proportionally.

ACCESSORIES - INERTIA



THREADED IMMERSION HEATING ELEMENTS FOR PRIMARY HEATING CIRCUIT

Threaded immersion heating elements for primary heating circuit					
Reference	Electric element model	KW	V	Length L*	Optional application to tank models
G003806	RI 4/2-22	2,2	3-230 / 3-400	260	G-80-...-1500-IF/IFS
G003807	RI 4/2-54	5,4	3-230 / 3-400	345	G-80-...-1500-IF/IFS
G003808	RI 4/2-72	7,2	3-230 / 3-400	445	G-200-...-1500-IF/IFS
G003809	RI 4/2-90	9,0	3-230 / 3-400	505	G-200-...-1500-IF/IFS
G003810	RI 4/2-120	12,0	3-230 / 3-400	680	G-600-...-1500-IF/IFS



Threaded immersion heating elements for primary heating circuit.

GEISER INERTIA EXTERNAL LININGS

External linings for "GEISER INERTIA" tanks. Padded PVC lining with zip fastener, B2 class according to DIN 4102-1. Standard external lining: BLUE / RAL 5015. Rest of colours OPTIONAL, according to availability and the quantities of product ordered.



BLUE: RAL 5015



WHITE: RAL 9016



GREY: RAL 7045

MASTER INERTIA EXTERNAL LININGS

External lining for "MASTER INERTIA" tanks with top cover, ND400 side manhole cover and trims for hydraulic connections. Standard external lining: GREY / RAL 7042. (OPTIONAL: linning for outdoor).



Capacity (l)	Standard category (ref KIT)	Class M0 (KIT reference)	Weatherproof (KIT reference)
800	FME800	FME800/M0	FME800/EX
1000	FME1000	FME1000/M0	FME1000/EX
1500	FME1500	FME1500/M0	FME1500/EX
2000	FME2000	FME2000/M0	FME2000/EX
2500	FME2500	FME2500/M0	FME2500/EX
3000	FME3000	FME3000/M0	FME3000/EX
3500	FME3500	FME3500/M0	FME3500/EX
4000	FME4000	FME4000/M0	FME4000/EX
5000	FME5000	FME5000/M0	FME5000/EX
6000	FME6000	FME6000/M0	FME6000/EX



ALUNOX EXTERNAL LINING

External aluminium sheet lining. ALUNOX external lining is supplied ready-mounted on the tank, over the PU insulation.

Capacity (l)	ALUNOX EXTERNAL LINING WITHOUT MANHOLE	ALUNOX EXTERNAL LINING WITH MANHOLE
800	FME800/ALUNOX	FME800/ALUNOX-B
1000	FME1000/ALUNOX	FME1000/ALUNOX-B
1500	FME1500/ALUNOX	FME1500/ALUNOX-B
2000	FME2000/ALUNOX	FME2000/ALUNOX-B
2500	FME2500/ALUNOX	FME2500/ALUNOX-B
3000	FME3000/ALUNOX	FME3000/ALUNOX-B
3500	FME3500/ALUNOX	FME3500/ALUNOX-B
4000	FME4000/ALUNOX	FME4000/ALUNOX-B
5000	FME5000/ALUNOX	FME5000/ALUNOX-B



INDUSTRIAL CAPACITY DHW STORAGE TANKS 7000 to 12000 litres

Flexiheat **offer** a range of DHW storage tanks with capacities of more than 7000 litres for special installations and industrial applications, **made in STAINLESS STEEL or COATED STEEL**

This range of tanks can be fitted with our system of detachable stainless steel coils, adapting the heat exchange area to the installation's thermal power.

They are also designed to incorporate electric heating elements, both for back-up heating and as main heating. Our "dry" electric heating system with ceramic heating elements can be integrated in the ND400 side manhole, allowing the heating elements to be replaced without having to drain the storage tank.

The main options available for these storage tanks are "**lapesa correx-up**" permanent cathodic protection units or detachable insulation in 50 or 100 mm-thick glassfibre with PVC external lining (separate supply).

INDUSTRIAL CAPACITY DHW STORAGE TANKS

EQUIPMENT

WITH COILS:

MXV and **MV** models can be fitted with one or two sets of **lapesa** detachable stainless steel coils, up to 10 m² of exchange area per set, adapting to the thermal power of the external source and the requirements of the installation.



EQUIPMENT

WITH ELECTRIC HEATING ELEMENTS:

The ND400 side manhole can be fitted with low charge density Incoloy electric heating elements to achieve a maximum power of 200 Kw. The equipment option with our "dry" system with ceramic heating elements allows to achieve a maximum power of 48 Kw. As a special manufacturing option, this range of storage tanks can include a second ND400 side manhole to obtain up to 400 Kw with immersion heating elements and 96 Kw electric power with ceramic heating elements.



APPLICATIONS

INDUSTRIAL CAPACITY STORAGE TANKS 7000 to 12000 litres

- Industrial applications
- Food industry
- Textile industry
- Large storage volume facilities
- Centralized DHW facilities
- Energy management centres
- Specific projects



INDUSTRIAL CAPACITY INERTIA BUFFER TANKS

TANKS: INERTIA

- Capacity: **7000 to 12000 litres.**
- Material: **S275JR carbon steel.**
- Working pressure: **6 bar.**
- Maximum working temperature: **110°C.**
- **ND400** side manhole.
- Internal treatment: free of particles.
- External treatment: rust prevention primer.
- Installation: vertical (horizontal as an option).
- OPTIONAL: electric heating elements.
- OPTIONAL: thermal insulation, flexible PVC external lining with 50 or 100 mm thick glass fibre, supplied separately.

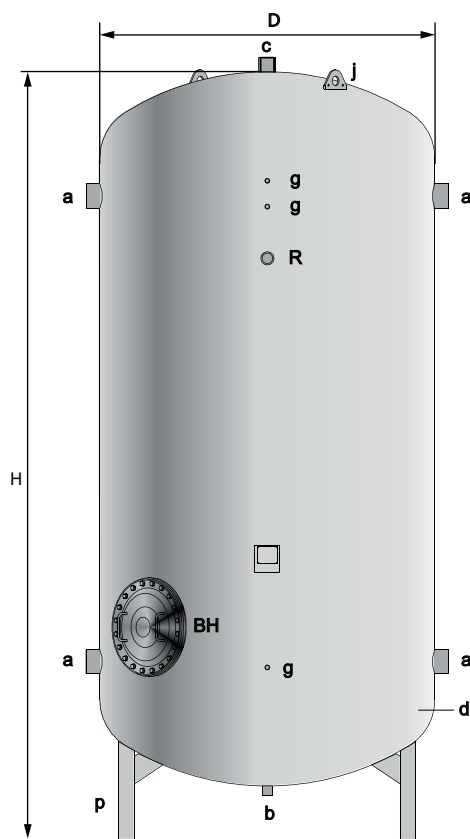

BH - Manhole ND400
 d - DHW tank
 j - Lifting lugs
 p - Support legs

GENERAL CHARACTERISTICS		MV-7000-IB	MV-8000-IB	MV-10000-IB	MV-12000-IB
Capacity	l.	7000	8000	10000	12000
D: external diameter	mm.	1750	1750	1750	1750
H: overall height	mm.	3652	4090	5013	5835
a: side connection	" GAS/F	4	4	4	4
b: lower connection	" GAS/F	1 1/4	1 1/4	1 1/4	1 1/4
c: upper connection	" GAS/F	2	2	2	2
R: side connection	" GAS/F	2	2	2	2
g: conexión sensores	" GAS/F	3/4	3/4	3/4	3/4
Side manhole	ND	ND400	ND400	ND400	ND400
Empty weight (approx.)	Kg	1005	1044	1243	1420

INDUSTRIAL CAPACITY STORAGE TANKS



ICON LEGEND:



HEAT PUMP



SOLAR COLLECTORS



GAS/OIL-FIRED BOILER



SOLID FUEL BOILER



ELECTRIC HEATING ELEMENTS



SEVERAL COMBINED ENERGY SOURCES



REGULATION AND CONTROL



THERMAL INSULATION



CATHODIC PROTECTION



ACCESSORIES



FLEXIHEAT UK LTD

www.flexiheatuk.com

01202 822221

PHW





INERTIA BUFFER TANKS



ISO 9001
BUREAU VERITAS
Certification

