

HEATING-COOLING DEVICE

LUNA

INSTRUCTION MANUAL



FLEXIHEAT UK LTD

www.flexiheatuk.com

01202 822221

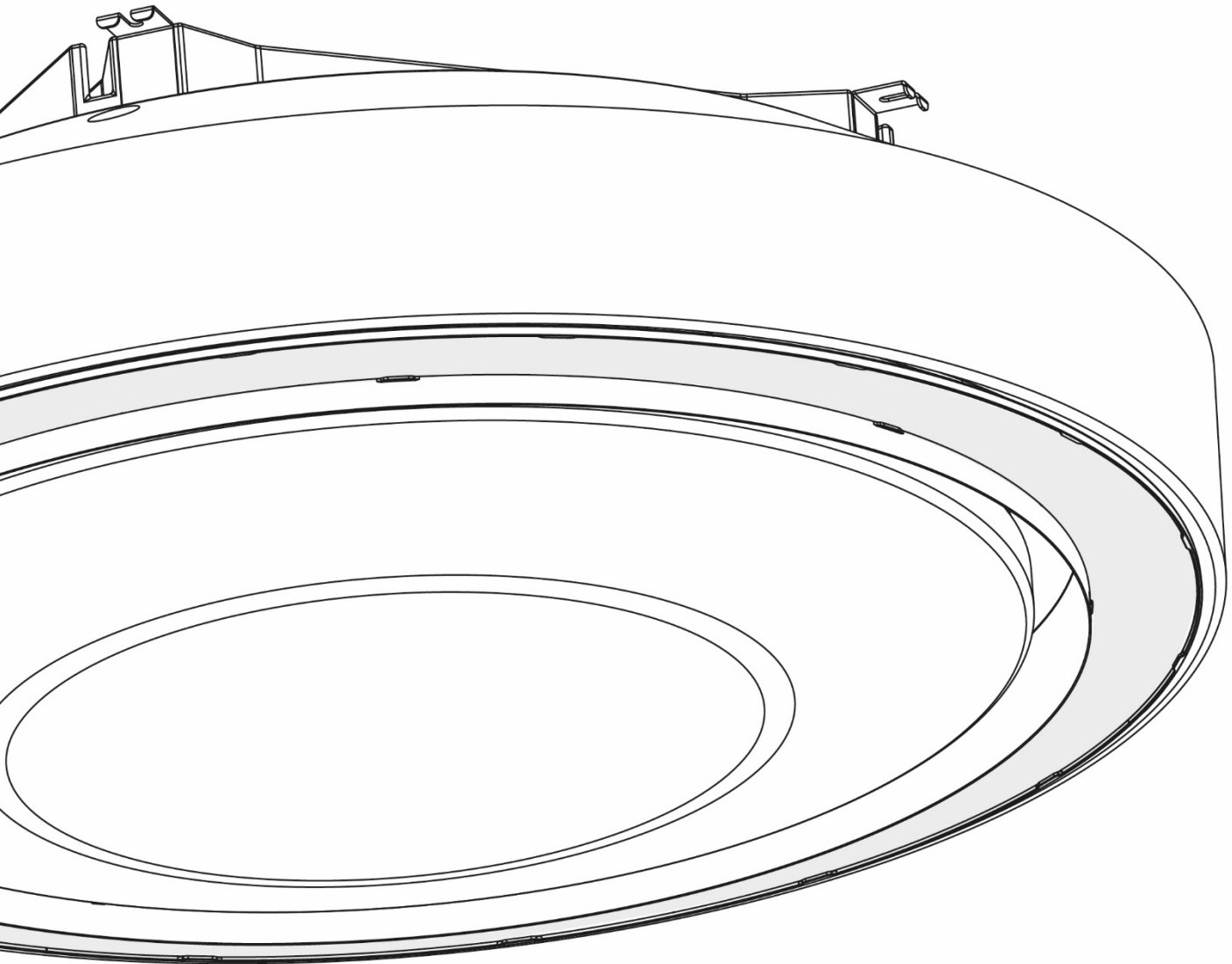

CONTENTS

TECHNICAL DOCUMENTATION

1.	IMPORTANT INFORMATION.....
2.	GENERAL INFORMATION.....
3.	CONSTRUCTION.....
4.	TECHNICAL DATA.....
5.	DIMENSIONS.....
6.	INSTALLATION – MINIMUM DISTANCES.....
7.	INSTALLATION.....
8.	CONNECTION OF ELECTRICAL INSTALALTION.....
9.	CONTROL CONNECTION.....
10.	CONNECTION OF HYDRAULIC INSTALLATION.....
11.	PARAMETERS OF THE HEATING MEDIUM.....
12.	CONDENSATE PUMP.....
13.	FILTER INSTALLATION.....
14.	ADDITIONAL ACCESSORIES.....
15.	CLEANING AND MAINTENANCE.....
16.	CONFORMITY WITH WEEE DIRECTIVE 2012/19/UE.....
17.	GENERAL WARRANTY TERMS.....
18.	GENERAL OPERATING CONDITIONS.....

TECHNICAL DOCUMENTATION

1. IMPORTANT INFORMATION

We have made every effort to make this manual as easy to understand as possible. However, if you have any difficulties, problems or questions, please contact sales@flexiheatuk.com
Also visit our website www.flexiheatuk.com

In this manual you will find important safety information and tips marked as below::



- Dangerous practices which may result in serious injury or death. Read all warnings before starting work.



- Unsafe practices which, if not avoided, may result in damage to property or minor injuries. Before starting work, read all cautions.



- Useful tips for the user and installer.

IMPORTANT SAFETY INFORMATION



1. Before installing, connecting, starting up, using and maintaining the device, please read this manual completely.
2. After receiving the product, check that it has not been damaged during transport. If the product appears to be damaged, **DO NOT START TO MOUNT THE DEVICE**; instead, you must immediately report the damage to the delivery man.
3. The device must be mounted in a stable way and in accordance with the instructions, in a place that can be easily accessed, thus ensuring the possibility of carrying out repairs and routine maintenance, as well as allowing easy and safe disassembly of the device.
4. The stability and durability of installation of the device depends on the structure of the building (in particular ceilings). The person performing the assembly should take these conditions into account when mounting the device.
5. The technical documentation should be kept in a safe place, easily accessible to the user and service technician.
6. Always test the operation of the device after installation.



1. The power connection shall be performed only by an authorized person.
2. Electrical devices should be connected to a fixed electrical installation equipped with means for disconnection from the power source, having contact breaks in all poles, ensuring full disconnection in overvoltage category III conditions.
3. The device requires periodic inspections in accordance with the instructions in this manual.
4. Do not hang/put pressure on the device.
5. Do not place any objects on the device or hang anything on the connection stubs.
6. The product should be stored and assembled out of the reach of small children.
7. The device is dedicated to work indoors with a maximum air dustiness of 0.3 g/m³. The device has elements made of aluminium, copper and steel and cannot be used in an corrosive environment.
8. Equipment cannot be used in an environment where oil mist is present.
9. This equipment may be used by children that are at least 8 years old, by persons with reduced physical and mental abilities and persons with no experience and knowledge of the equipment, on condition that the supervision or instruction regarding correct use of the equipment in a safe manner is provided and the possible threats are understood. The device cannot be used by children to play. Unattended children should not clean or maintain the equipment.



1. The device is powered by dangerous voltage. Always disconnect the device from the power supply before servicing or accessing its internal components.
2. Do not insert your fingers or any objects inside the device.
3. Do not cover the device.

2. GENERAL INFORMATION

LUNA is a high-quality ceiling unit for space heating and cooling.

The device is equipped with an innovative movable nozzle and an EC fan, which enables stepless adjustment of the air flow rate and direction from the controller level.

The device is dedicated ONLY for indoor use and is designed to ceiling mounting, it is also possible to mount it in a suspended ceiling.

The air is drawn in from the top of the device and, depending on the operating mode, is supplied to the room at the appropriate angle. The change in airflow direction is done automatically using a movable nozzle.

The LUNA device is available in three versions:

LUNA 2H - heating device in a 2-pipe system

LUNA 2HC - heating and cooling device in a 2-pipe system

LUNA 4HC - heating and cooling device in a 4-pipe system

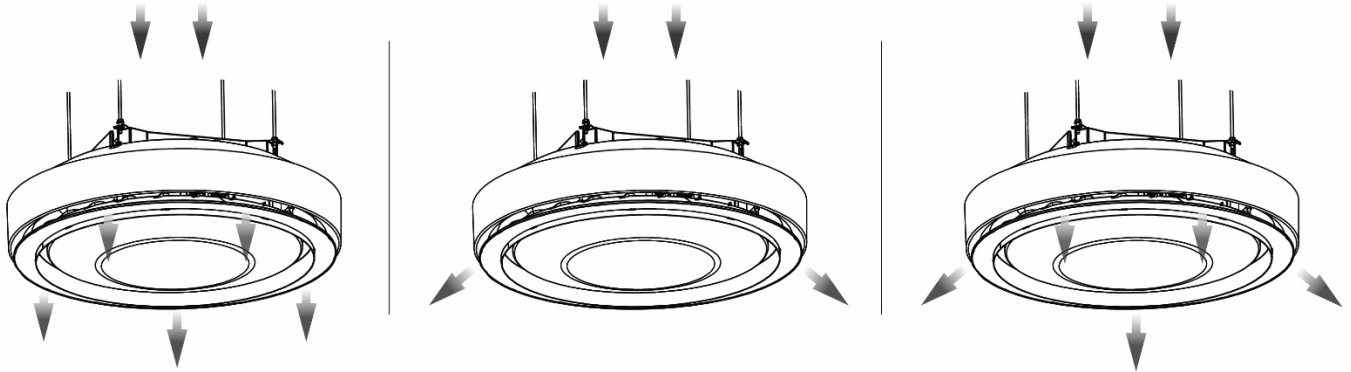
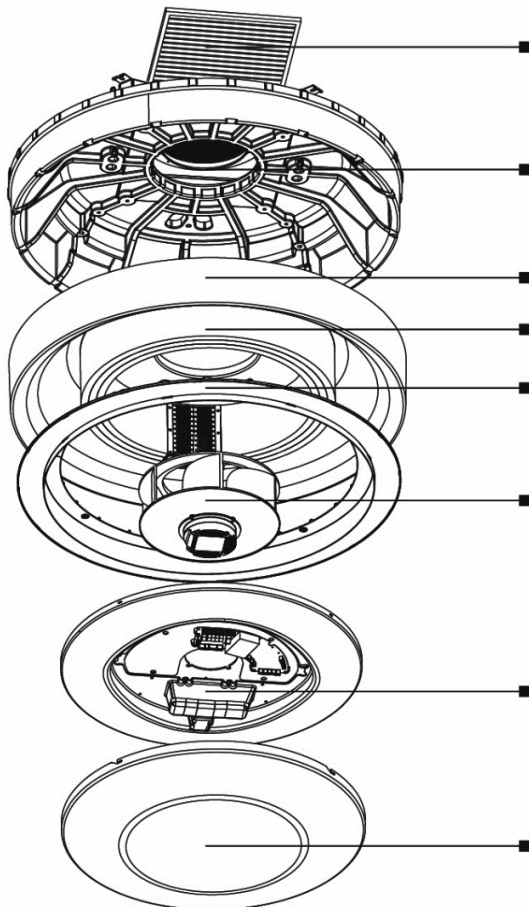

FIG. 2.1 AIRFLOW DIRECTION - BOTTOM SUPPLY / SIDE SUPPLY / MIXED SUPPLY

3. CONSTRUCTION



Coarse Filter 70% (~G4) - enables the filtration of recirculated air.

EPP Housing - a lightweight and durable housing made of expanded polypropylene (EPP) that provides proper thermal and acoustic insulation.

Casing - external casing available in white or black color.

Heat exchanger - a heat exchange unit that allows heating or cooling, available in a 2-pipe or 4-pipe system.

Automatic 360° air nozzle - an innovative supply nozzle that allows adjustment of the airflow angle from the controller.

EC Fan - energy-efficient EC fan with variable speed control, allowing smooth and continuous adjustment of the airflow.

Drip tray - made of a disinfectant-resistant plastic material. Access to the tray is possible from the bottom of the device.

Lower housing cover - Provides easy access to the device components. Available in RAL 9003 (white) or RAL 9004 (black).

FIG. 3.1 CONSTRUCTION

4. TECHNICAL DATA

		LUNA 2H	LUNA 2HC	LUNA 4HC
Nominal airflow *	[m ³ /h]	700 - 3500		
Nominal heating capacity [70/50 °C temp. internal 16 °C]	[kW]	10.0 - 32.5	10.0 - 32.5	4.3 - 11.3
Heating capacity [45/40 °C temp. internal 16 °C]	[kW]	5.9 - 20.0	5.9 - 20.0	2.8 - 7.4
Nominal cooling capacity [7/12 °C, temp. internal 26 °C 50%]	[kW]	-	5.2 - 14.6	4.1 - 10.3
Acoustic power level **	[dB(A)]	37 - 54		
Min. operating temperature of the room	[°C]	3		
Max. operating temperature of the room	[°C]	45.0		
Maximum flow range. ***	[m]	8.0		
IP	[-]	IP20		
Weight	[kg]	33.0		

Hydraulic data

Weight of unit filled with water	[kg]	36.0		
Max. water temperature	[°C]	80.0		
Max. water pressure	[bar]	16		
Connection stubs	["]	3/4	3/4	2 x 3/4

Electrical data

Power supply	[V/Hz]	230/50		
Current consumption	[A]	1.7		
Power consumption	[kW]	0.39		

*At the air inlet under the device, the efficiency value is 85% of the nominal efficiency value.

**The acoustic pressure level is provided assuming operation with a filter, air inlet under the device, and in a soundproofed room. The room volume is 3000 m³, the distance from the sound source is 5 m, and the reverberation time is 2.0 s.

***Vertical range of a non-isothermal stream at $\Delta T = 50^{\circ}\text{C}$, at the critical velocity of 0.5 m/s..

5. DIMENSIONS

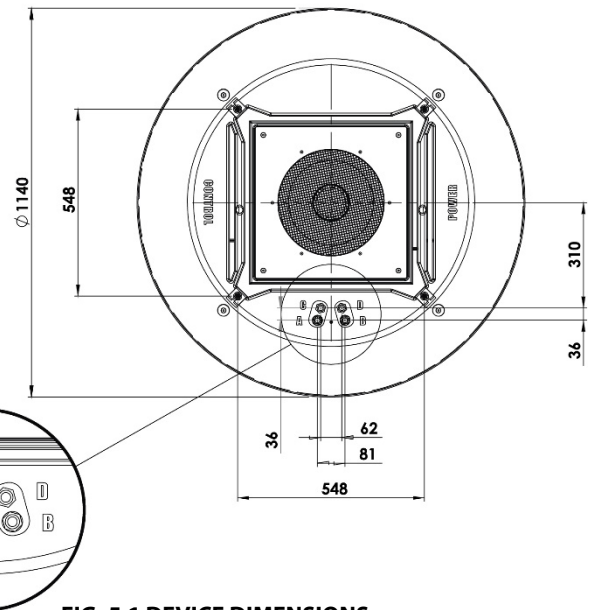
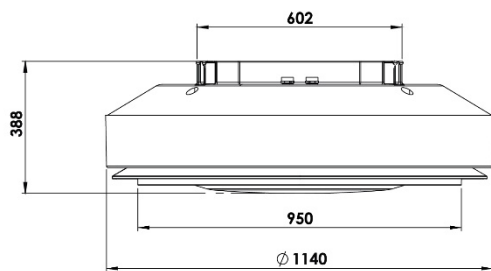

	Luna 2H / 2HC	Luna 4HC
A	Return (Cooling/Heating)	Supply (Cooling)
B	Supply (Cooling/Heating)	Supply (Heating)
C	-	Return (Cooling)
D	-	Return (Heating)

FIG. 5.1 DEVICE DIMENSIONS

6. INSTALLATION – MINIMUM DISTANCES

During installation, it is necessary to maintain minimum required distances from vertical and horizontal partitions. Additionally, a minimum recommended distance should be maintained between successive devices. Prior to initial startup, the device must be leveled.

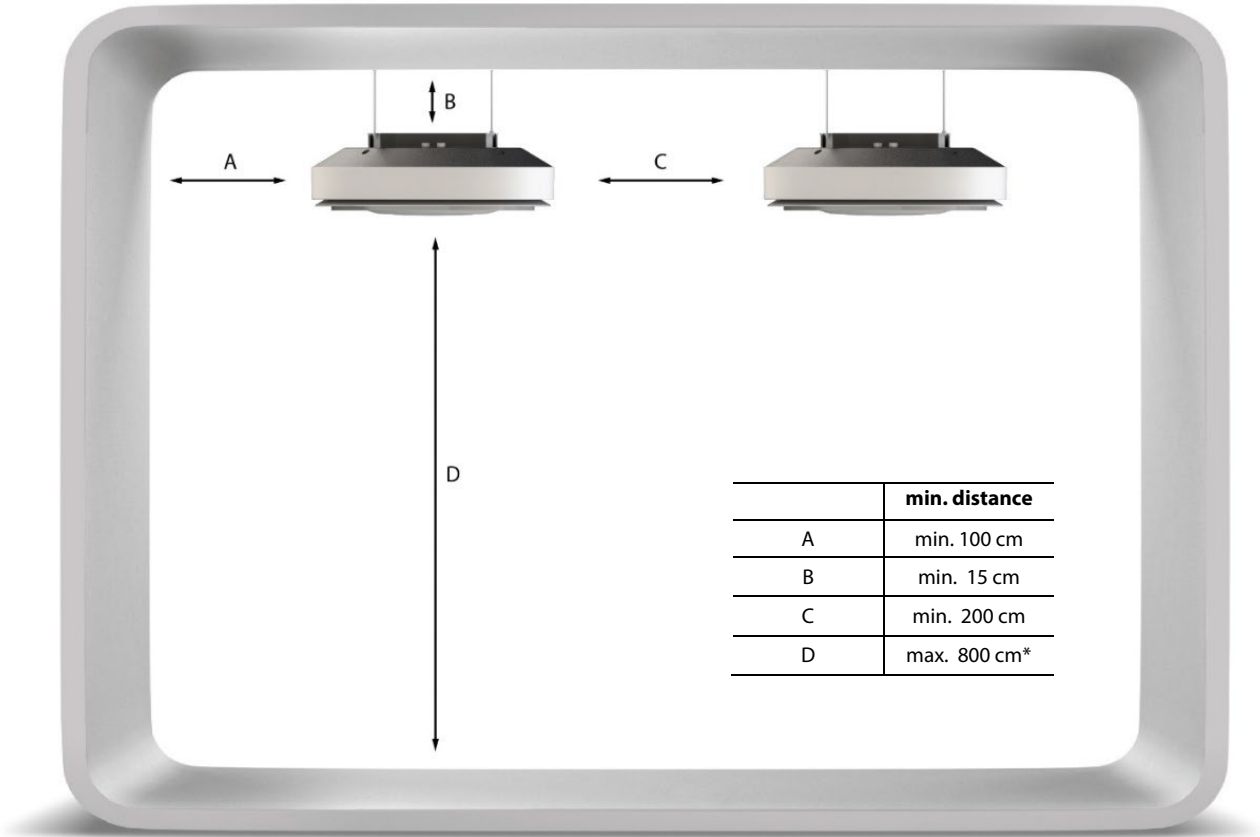

FIG. 6.1 REQUIRED INSTALLATION DISTANCES



*depending on the operating mode of the device.

7. INSTALLATION

INSTALLATION IN THE CEILING

The LUNA device is designed for horizontal installation using 4 threaded M8 rods. The installation process should begin by preparing 4 mounting holes in the ceiling according to drawing [7.1].



It is recommended to prepare the water installation for connecting the device before installing it in the ceiling.

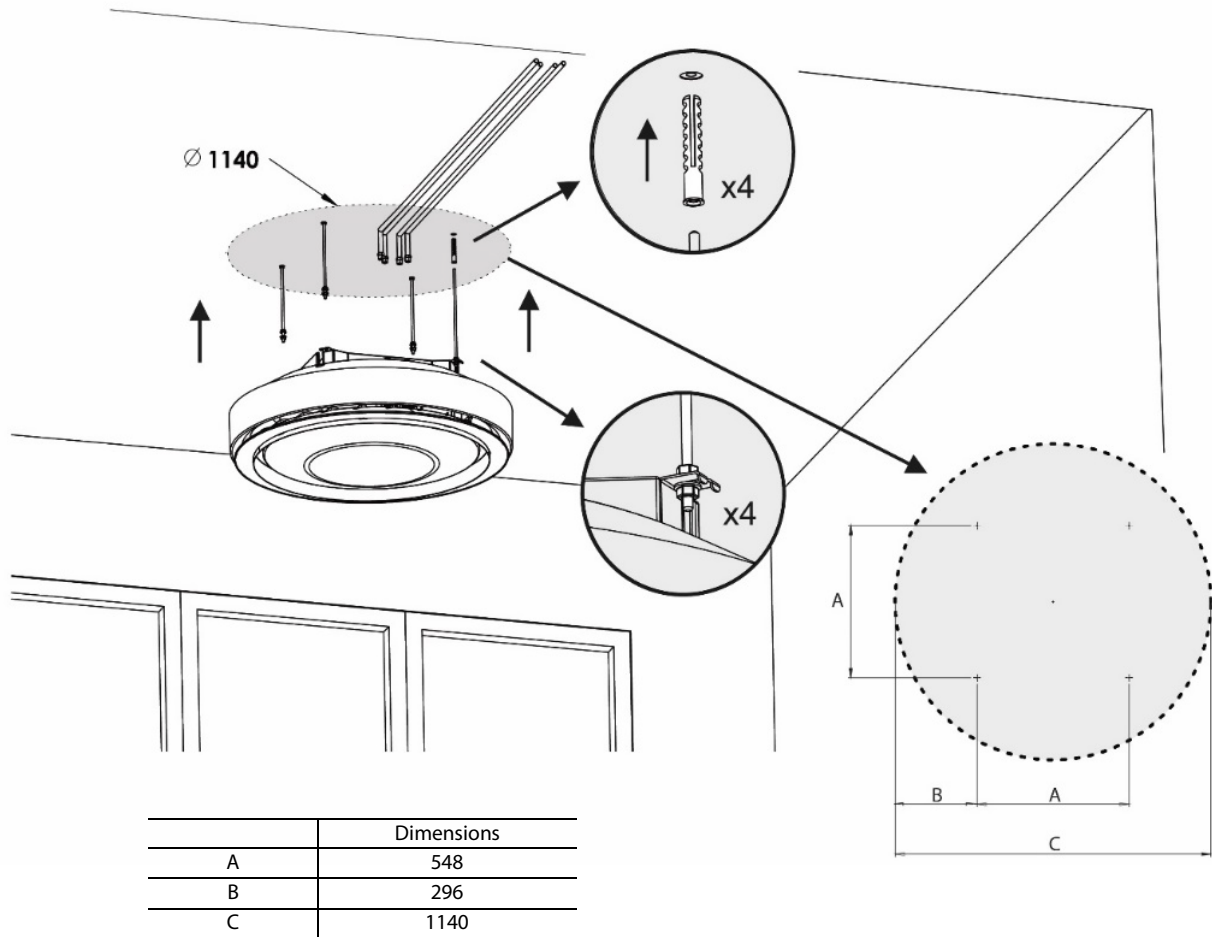
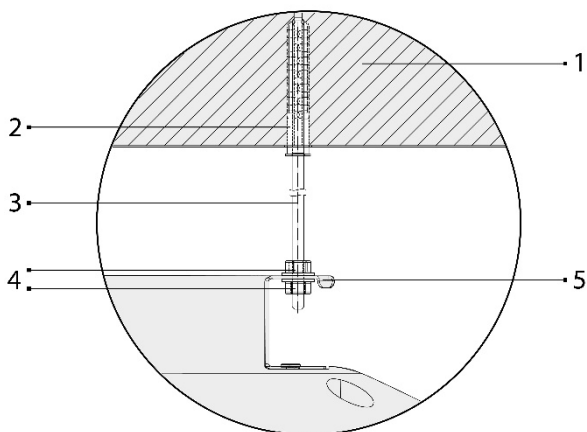

FIG. 7.1 INSTALLATION IN THE CEILING

Next, the mounting studs should be installed in the solid ceiling using, for example, expansion anchors or chemical anchors, and then secure the device according to the following diagram.



- 1 – Ceiling
- 2 – Expansion anchor or chemical anchor
- 3 – M8 threaded rods
- 4 – M8 bolt with a washer
- 5 – Mounting brackets



- 1. The ceiling must have sufficient load-bearing capacity.
- 2. The device must be leveled.



FIG. 7.2 SAMPLE INSTALLATION IN THE CEILING

The manufacturer does not provide the mentioned mounting accessories

INSTALLATION IN A SUSPENDED CEILING

The LUNA device is designed for horizontal installation using 4 threaded M8 rods. The installation process should begin by preparing 4 mounting holes in the ceiling according to drawing [7.3].



It is recommended to prepare the water installation for connecting the device before installing it in the ceiling.



In case of installation in a suspended ceiling, it is necessary to provide an access panel that allows easy access to hydraulic manifolds and enables air filter replacement.

A ventilation grille should be used in the suspended ceiling to facilitate air circulation from the room. The dimensions of the grille should be selected based on specific project requirements each time..

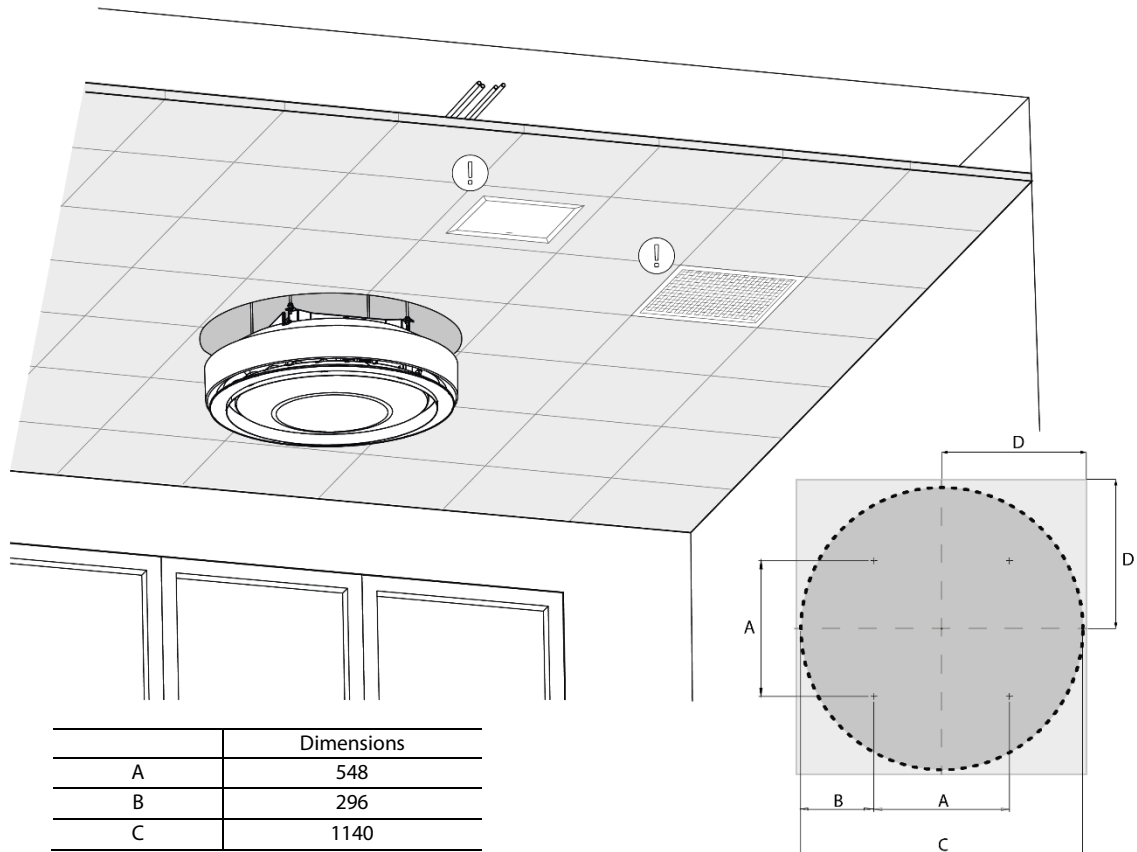
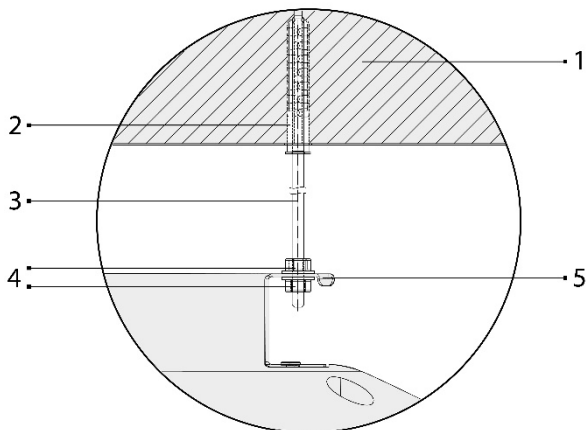

FIG. 7. INSTALLATION IN A SUSPENDED CEILING

Next, the mounting studs should be installed in the solid ceiling using, for example, expansion anchors or chemical anchors, and then secure the device according to the following diagram.



- 1 – Ceiling
- 2 – Expansion anchor or chemical anchor
- 3 – M8 threaded rods
- 4 – M8 bolt with a washer
- 5 – Mounting brackets



- 1. The ceiling must have sufficient load-bearing capacity.
- 2. The device must be leveled.

FIG. 7.4 SAMPLE INSTALLATION IN THE CEILING



The manufacturer does not provide the mentioned mounting accessories

FASCIA DIMENSIONS

For devices installed in a suspended ceiling, the manufacturer provides an optional ceiling diffuser. The diffuser ensures a suitable aesthetic appearance when installed in a suspended ceiling.

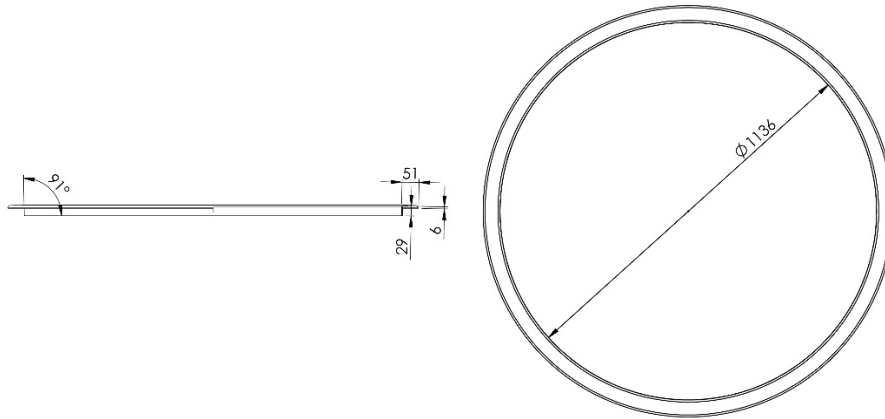

FIG. 7.5 FASCIA DIMENSIONS

FASCIA INSTALLATION

The installation of the ceiling diffuser should be carried out after the prior installation of the device following the above instructions. To do so, apply adhesive to the mounting flange of the diffuser and then slide the diffuser onto the device, ensuring that it adheres to the suspended ceiling.

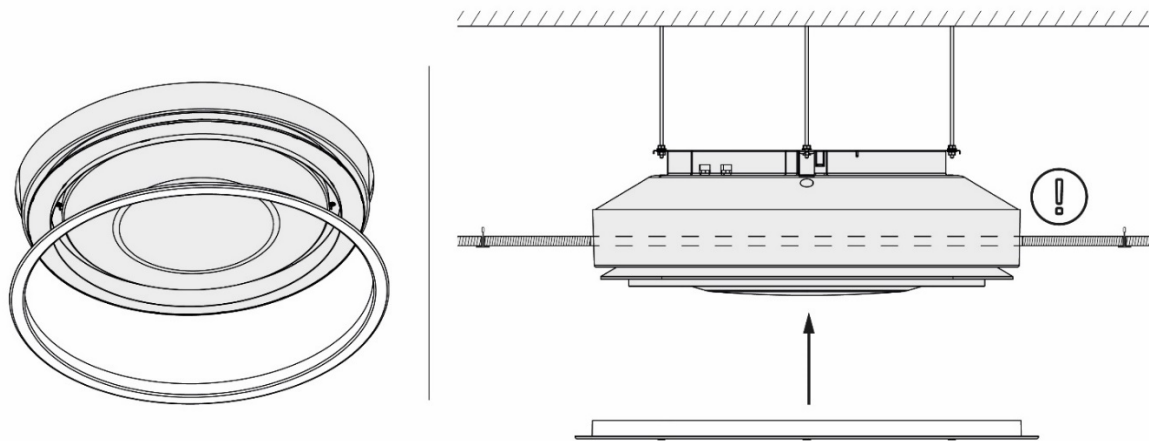

FIG. 7.6 FASCIA INSTALLATION

The fascia can be mounted within the range of 0-100 mm (A), where 0 represents aligning the diffuser with the bottom edge of the housing

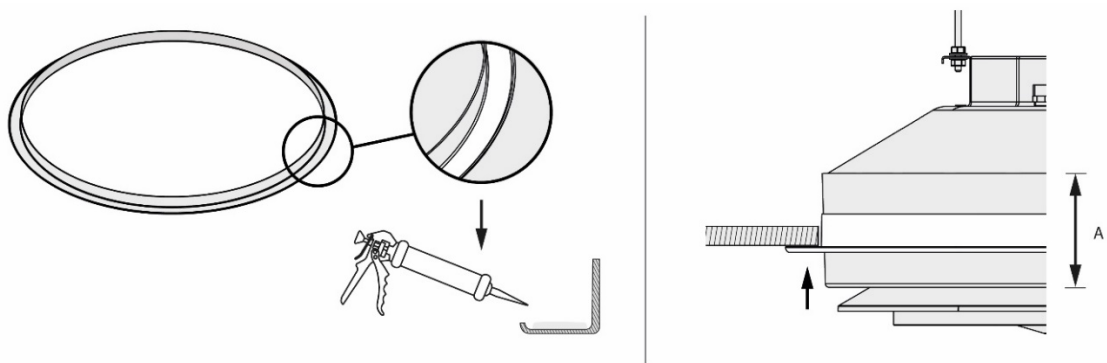

FIG. 7.7 FASCIA INSTALLATION



The device must be leveled

8. CONNECTION OF ELECTRICAL INSTALALTION

It is recommended to route the power cable along one of the mounting rods [A]. Then, run the cable along the prepared conduit to the opening in the device [B] on the side marked as POWER.

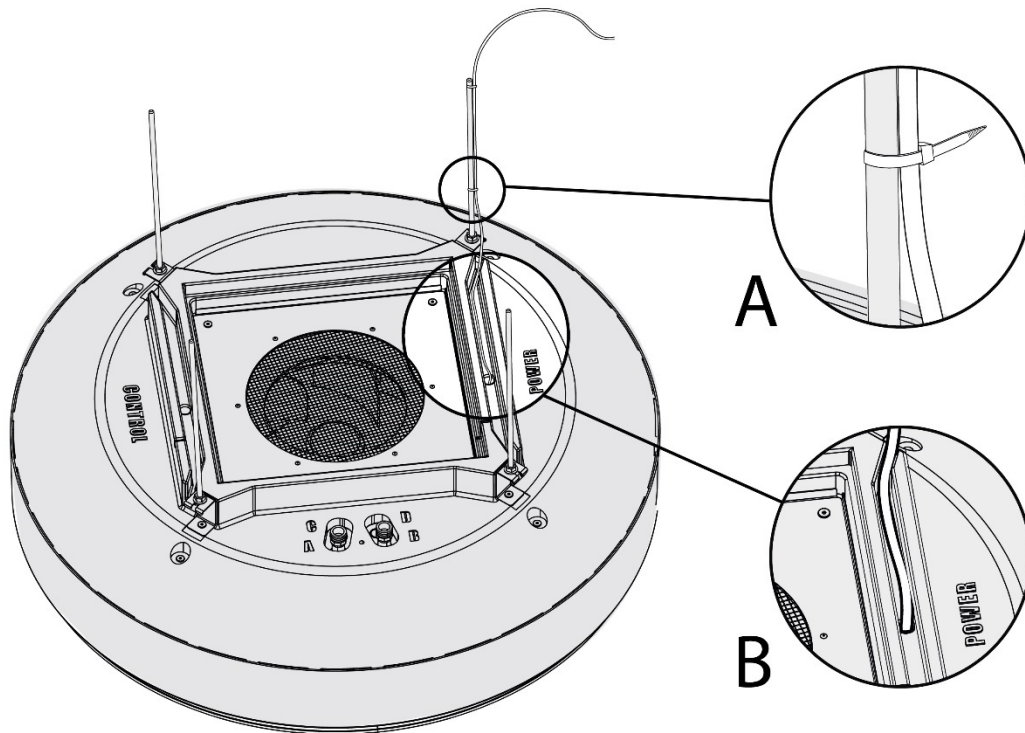

FIG. 8.1 ROUTING THE POWER CORD

Next, remove the bottom cover of the device. To do this, rotate the allen screw three times using a 2.5 mm hex key [A], and twist the screws at points [B] three times using your hand. Then, rotate the entire cover counterclockwise to remove it.

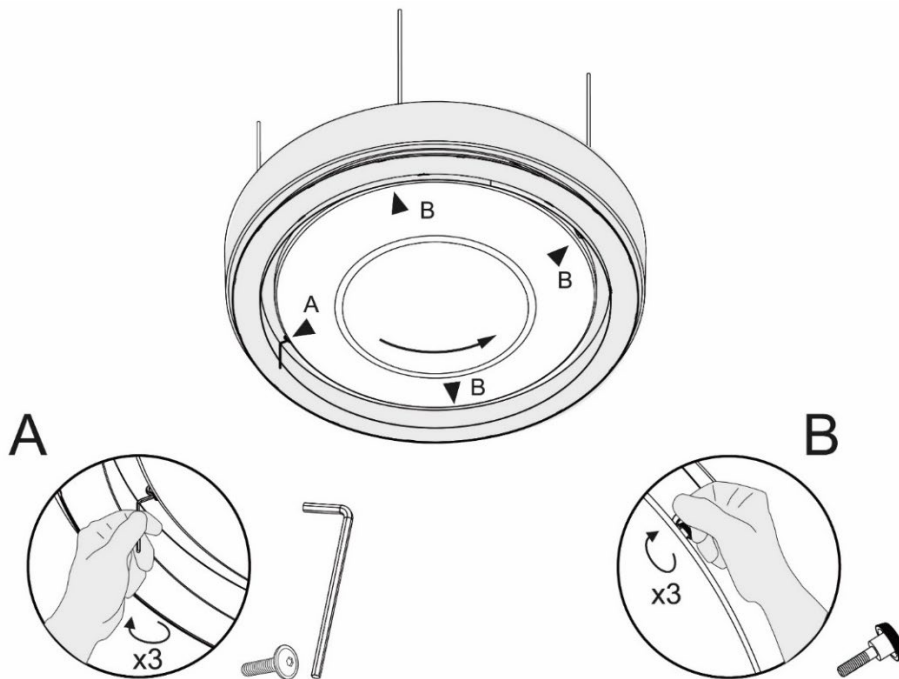

FIG. 8.2 REMOVING THE BOTTOM COVER

The cable routed through the opening [C] should be connected to the prepared connectors [D], using cable clip holders [E]. Then, connect the power cable according to the diagram [8.4].

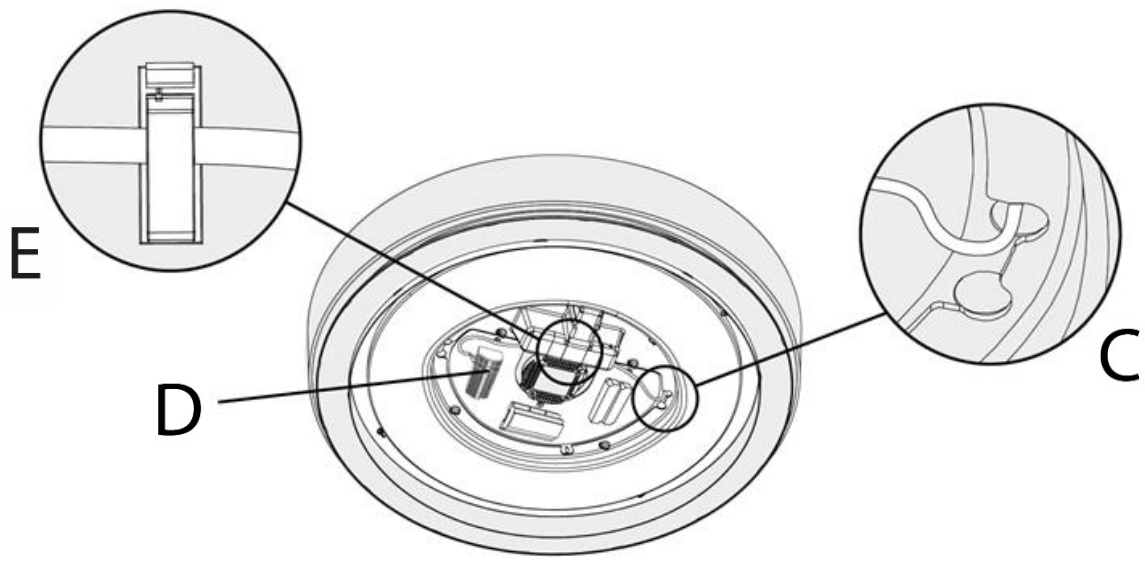

FIG. 8.3 CONNECTION OF ELECTRICAL INSTALALTION

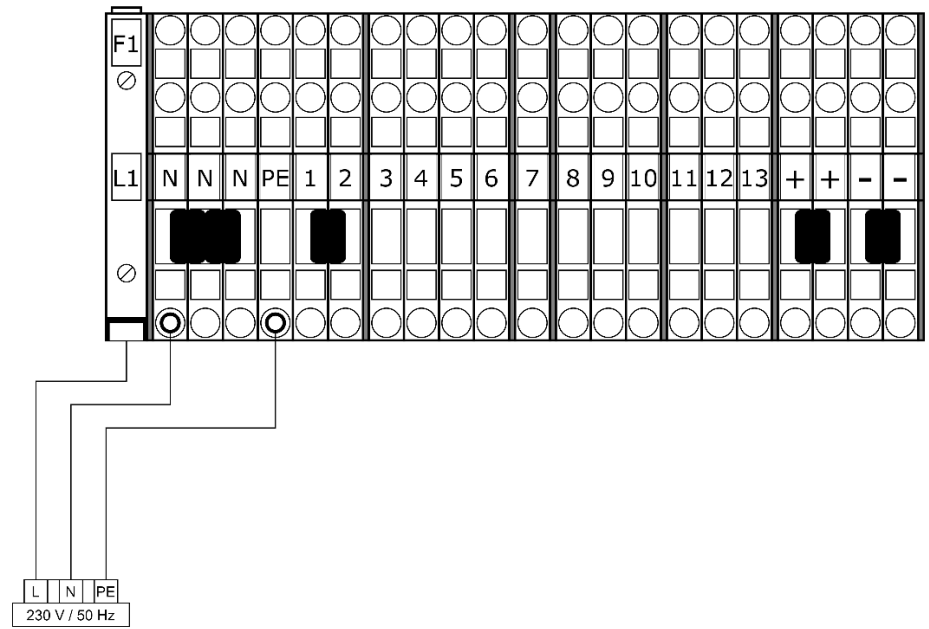

FIG. 8.4 ELECTRICAL DIAGRAM

9. CONTROL CONNECTION

The power-control cables are recommended to be routed along one of the mounting rods [A]. Then, run the cables along the prepared conduit to the opening in the device [B] on the side marked as CONTROL.

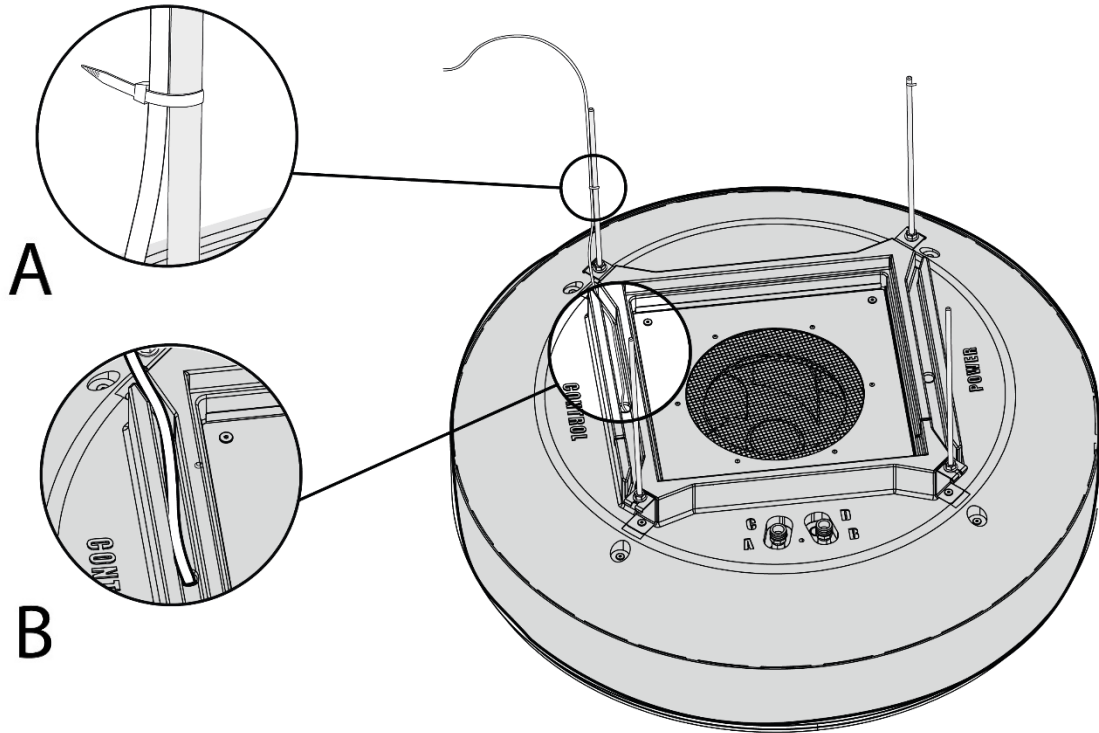

FIG. 9.1 ROUTING THE CONTROL CORD

Next, remove the bottom cover of the device. To do this, rotate the allen screw three times using a 2.5 mm hex key [A], and twist the screws at points [B] three times using your hand. Then, rotate the entire cover counterclockwise to remove it.

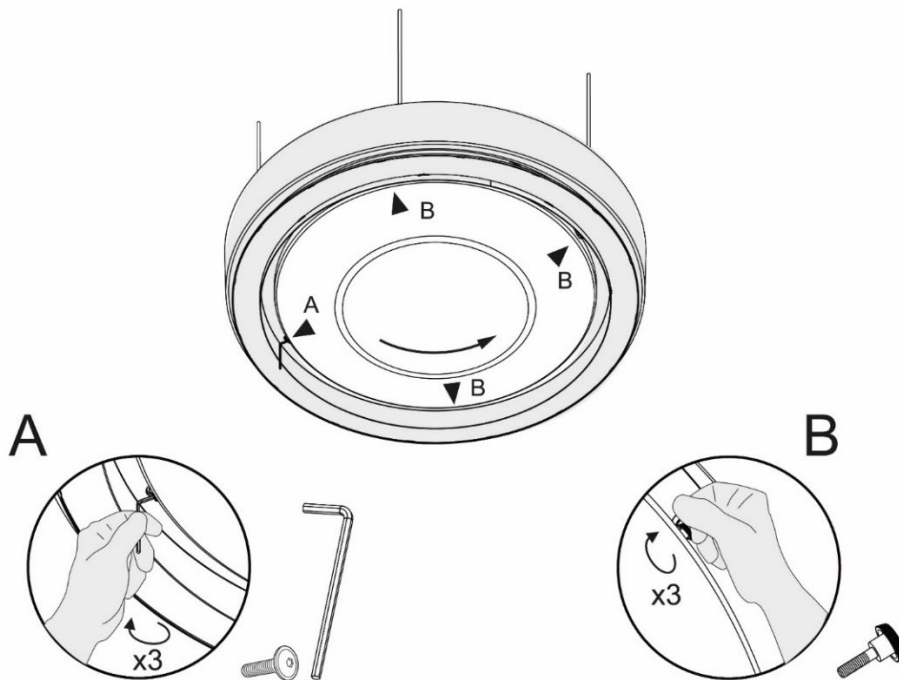

FIG. 9.2 REMOVING THE BOTTOM COVER

The cable routed through the opening [C] should be connected to the prepared connectors [D]. Then, connect the control cables according to the diagram [9.4].

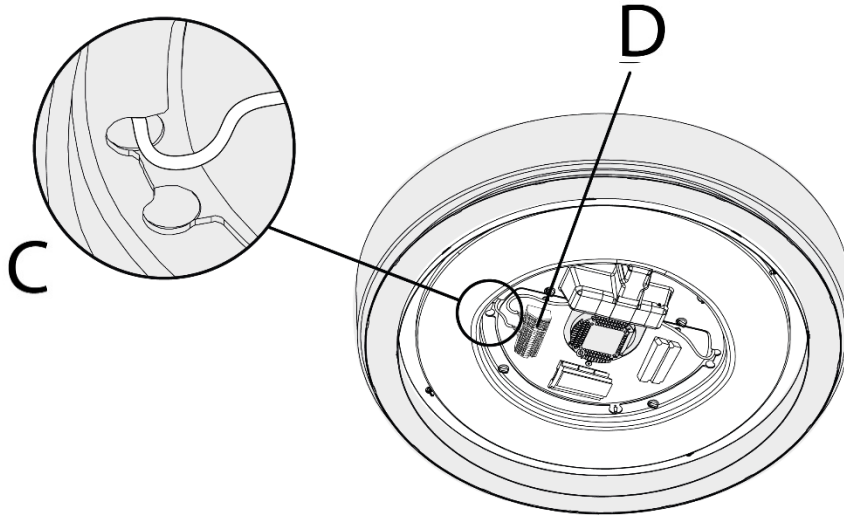

FIG. 9.3 CONTROL CONNECTION

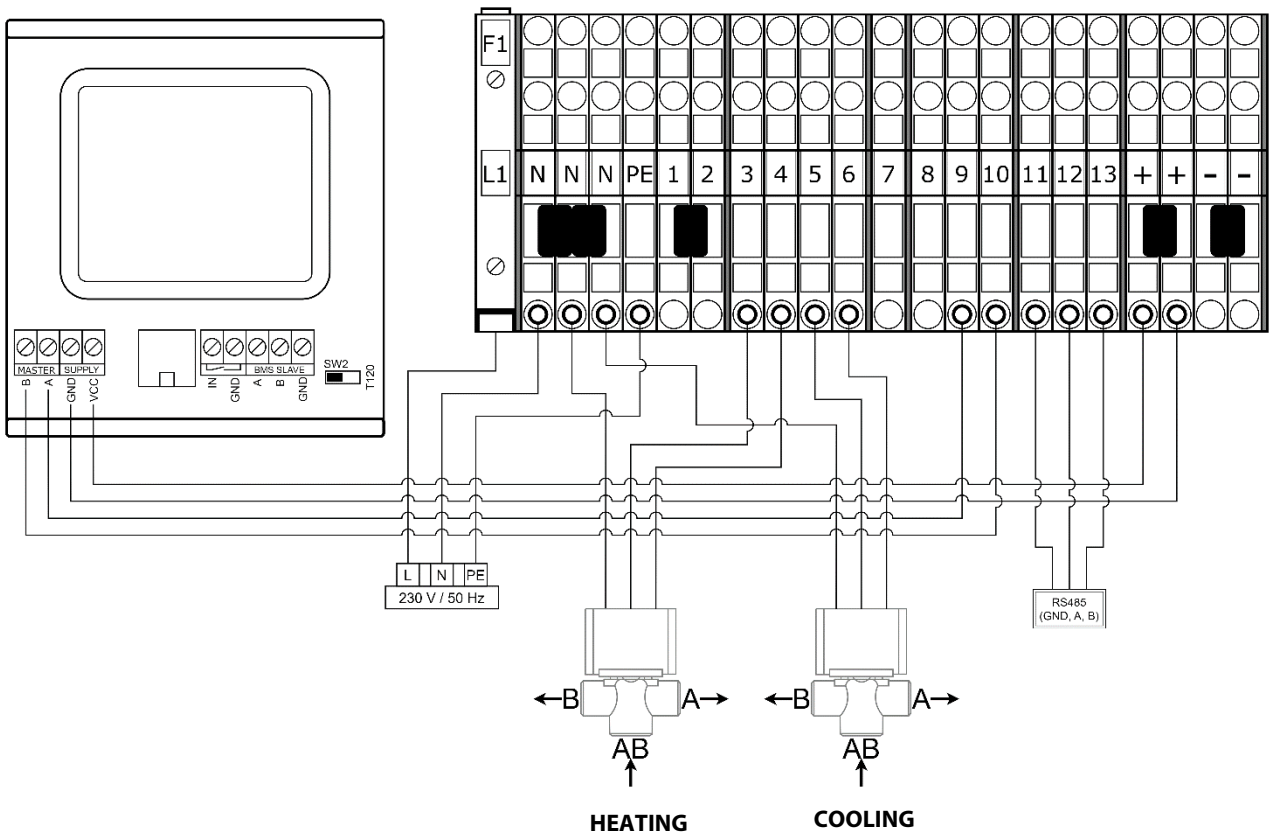
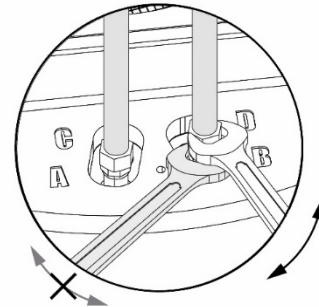
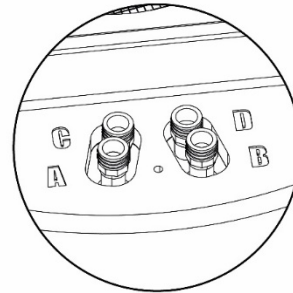
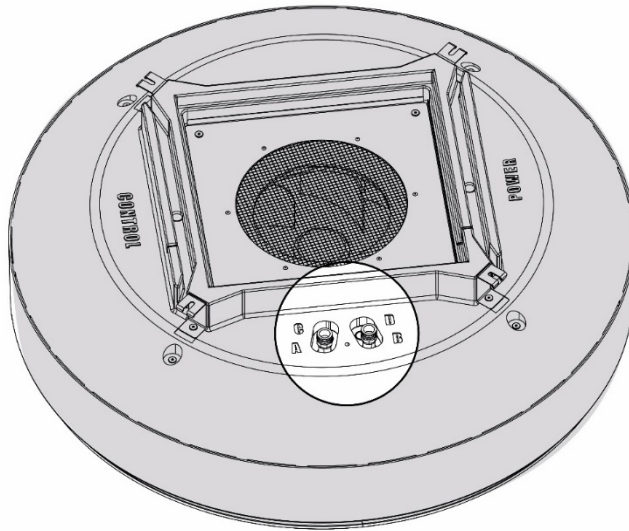

FIG. 9.4 ELECTRICAL DIAGRAM – CONTROL CONNECTION

10. CONNECTION OF HYDRAULIC INSTALLATION

The connection stubs are located in the upper part of the device. Depending on the device version, the cables should be connected according to the table below. The device version can be read from the nameplate located in the upper part of the device on the fan plate.

	Luna 2H / 2HC	Luna 4HC
A	Return (Cooling/Heating)	Supply (Cooling)
B	Supply (Cooling/Heating)	Supply (Heating)
C	-	Return (Cooling)
D	-	Return (Heating)



RYS.10.1 HYDRAULIC CONNECTION



WARNING

1. Before connecting the water installation, disconnect the power supply to the device.
2. The connection should be made in a way that avoids stress. It is recommended to use flexible hoses for conveying the medium. Flexible hoses are not provided with the device.
3. The hydraulic installation must be protected against an increase in the heating medium pressure above the allowable value (16 bar).
4. Before starting the device, check the correct connection of the heating medium lines and the tightness of the installation.
5. During the installation, it is imperative to immobilize the exchange unit connection fittings (counteract).
6. After filling the system with the medium, check the tightness of the hydraulic connections.



ADVICE

1. It is recommended to use air vent valves at the highest point of the installation
2. The installation should be done in a way that allows for easy removal of the device in case of a malfunction (the use of flexible hoses is recommended). For this purpose, shut-off valves should be installed close to the device.

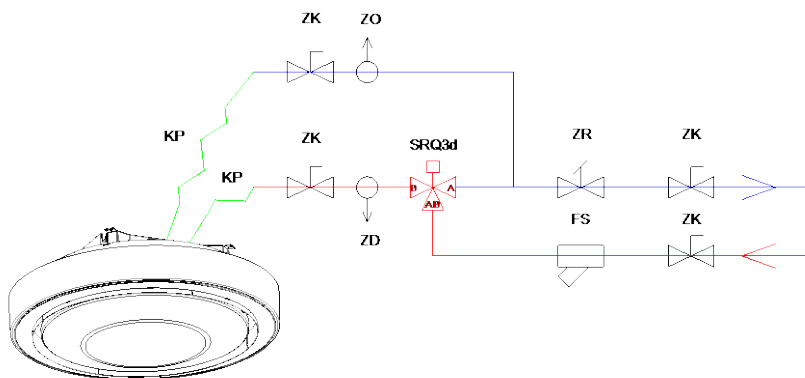

ZK	shut-off valve
ZO	air vent valve
ZR	balancing valve
KP	flexible hoses
SRQ3d	3-way valve with actuator

Optional equipment

ZD	drain valve
FS	strainer filter

FIG.10.2 SCHEMATIC HYDRAULIC DIAGRAM

11. PARAMETERS OF THE HEATING MEDIUM

The water heat exchanger can be supplied with water or glycol solutions up to 30% . The heat exchanger tubes are made of copper. The heating medium should not cause corrosion of this material. In particular, the parameters as below should be provided.

Parameter	Value
pH	7.5-9.0
Pollution	Free of sediments/particles
Total hardness	$[Ca^{2+}, Mg^{2+}] / [HCO_3^-] > 0.5$
Oil and grease	<1 mg/l
Oxygen	<0.1mg/l
HCO ³	60-300 mg/l
Ammonia	< 1.0 mg/l
Sulphides	< 0.05 mg/l
Chlorides, Cl	<100 mg/l

12. CONDENSATE PUMP

Luna devices with cooling function are equipped with a condensate drain pump as standard. The condensate is drained through a hose, which is routed to the upper part of the device, near the hydraulic connections. The hose should be connected to the collective condensate drain system. The maximum lifting height of the pump is 20 m.

13. FILTER INSTALLATION

The LUNA device is equipped with a COARSE 70% (G4) air filter as standard, which is installed on the upper surface of the device. The filter should be replaced periodically, depending on the level of contamination or the number of hours of device operation. The T-box ZONE controller will indicate the need for air filter replacement after a certain number of operating hours. It is always recommended to use original filters.



Please make sure that the filter is installed in the correct airflow direction (indicated on the filter frame).

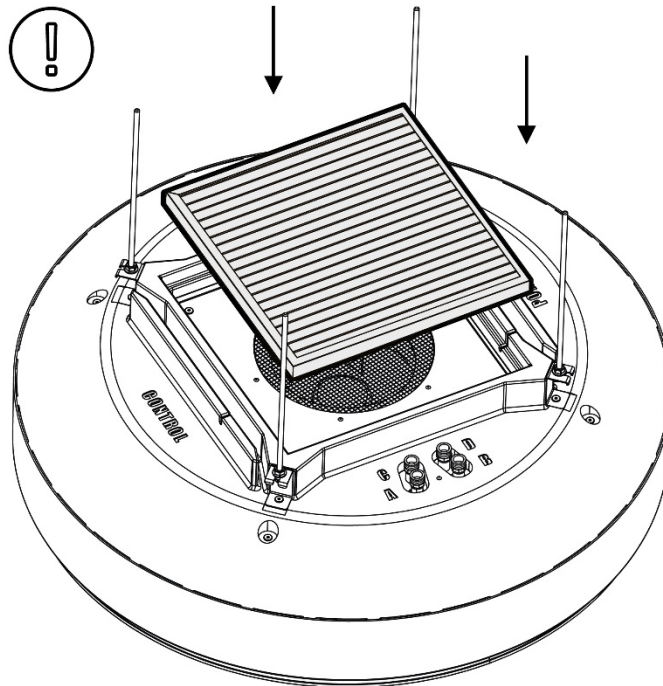

FIG. 13.1 FILTER INSTALLATION

14. ADDITIONAL ACCESSORIES

3-WAY VALVE WITH A 3-POINT ACTUATOR

The manufacturer provides an optional 3-way valve with a 3-point actuator.



IP40
Power supply: AC 230 V

2-WAY VALVE WITH AN ON/OFF ACTUATOR

The manufacturer provides an optional 2-way valve with an ON/OFF actuator.



IP20
Power supply: AC 230 V

ROOM TEMPERATURE SENSOR

The manufacturer optionally provides a room temperature sensor designed for wall mounting as a component.



IP65
Height: 130 mm
Width: 40 mm
Length: 55 mm
Type: NTC10K

DRIP TRAY TO VALVE WITH ACTUATOR

As an optional component, the manufacturer provides a drip tray for the valve with actuator. The drip tray should be installed and leveled according to the following diagram. The installation should be done using M8 screws, which are not included in the set.

Condensate drainage from the drip tray is achieved through a stub, to which a tubing of the specified diameter should be connected by pressing it in.

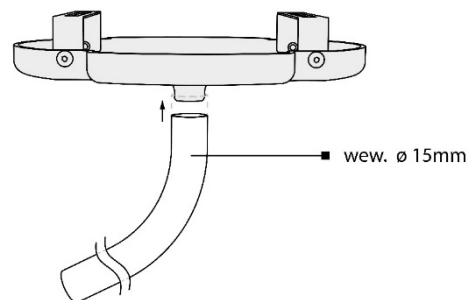
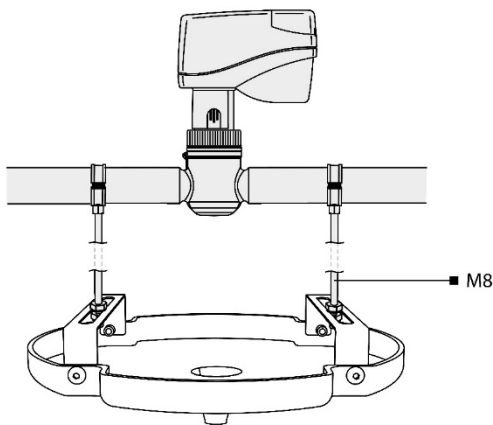

1. The manufacturer does not provide mounting screws,
2. The manufacturer does not provide tubing for condensate drainage.

15. CLEANING AND MAINTENANCE

The manufacturer recommends performing cleaning and maintenance twice a year, before and after the cooling season. The maintenance tasks should be carried out according to the following instructions.



Before starting the maintenance procedures, it is necessary to turn off the device and then disconnect it from the power supply.

The first step is to remove the bottom cover of the device. To do this, you need to turn the Allen screw three times using a 2.5 mm hex key [A], and then rotate the screws at points [B] three times by hand. Next, rotate the entire cover in a counterclockwise direction.

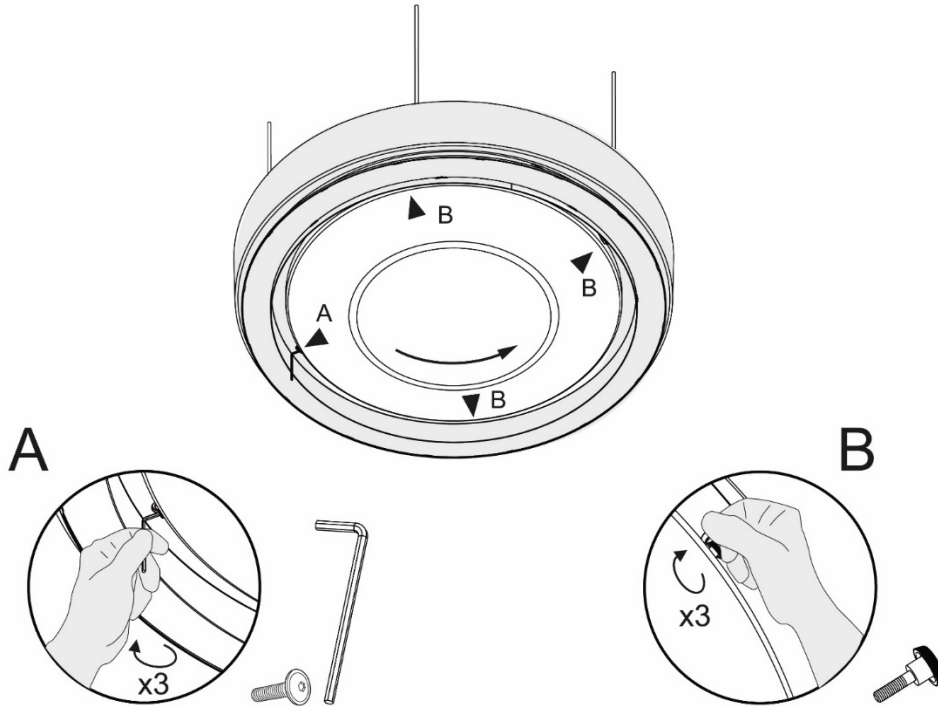

FIG. 15.1 REMOVING THE BOTTOM COVER

After removing the cover, it is necessary to disconnect the power supply and detach the carabiner supporting the bottom cover [C].

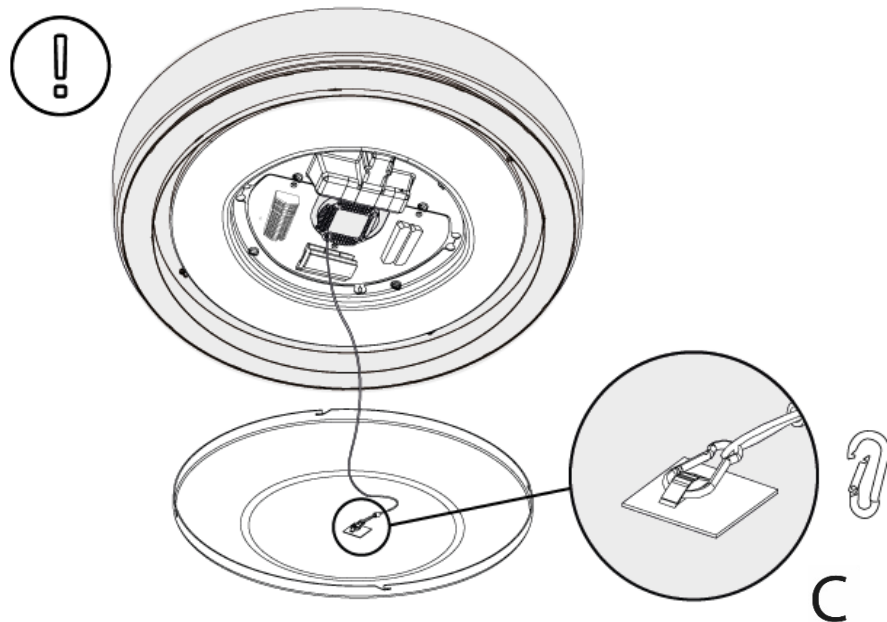

FIG. 15.2 POWER DISCONNECTION



Before proceeding with further tasks, it is important to empty the condensate tray by removing the drain plug and draining the condensate [15.3]. The drain plug is marked with an exclamation mark in figure [15.4].

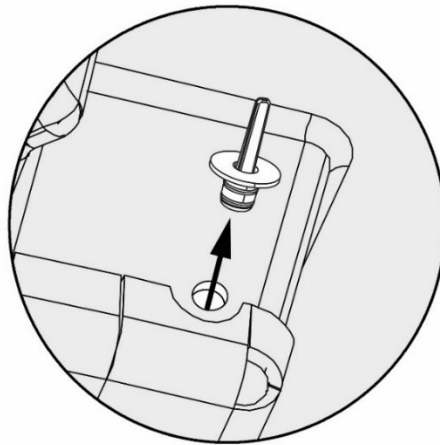

FIG. 15.3 EMPTING THE CONDENSATE TRAY - DRAIN PLUG

To remove the condensate tray, you need to completely unscrew the allen screw [A], remove the screws at points [B], and unscrew the 6 butterfly screws [E]. Then, carefully lower the tray.

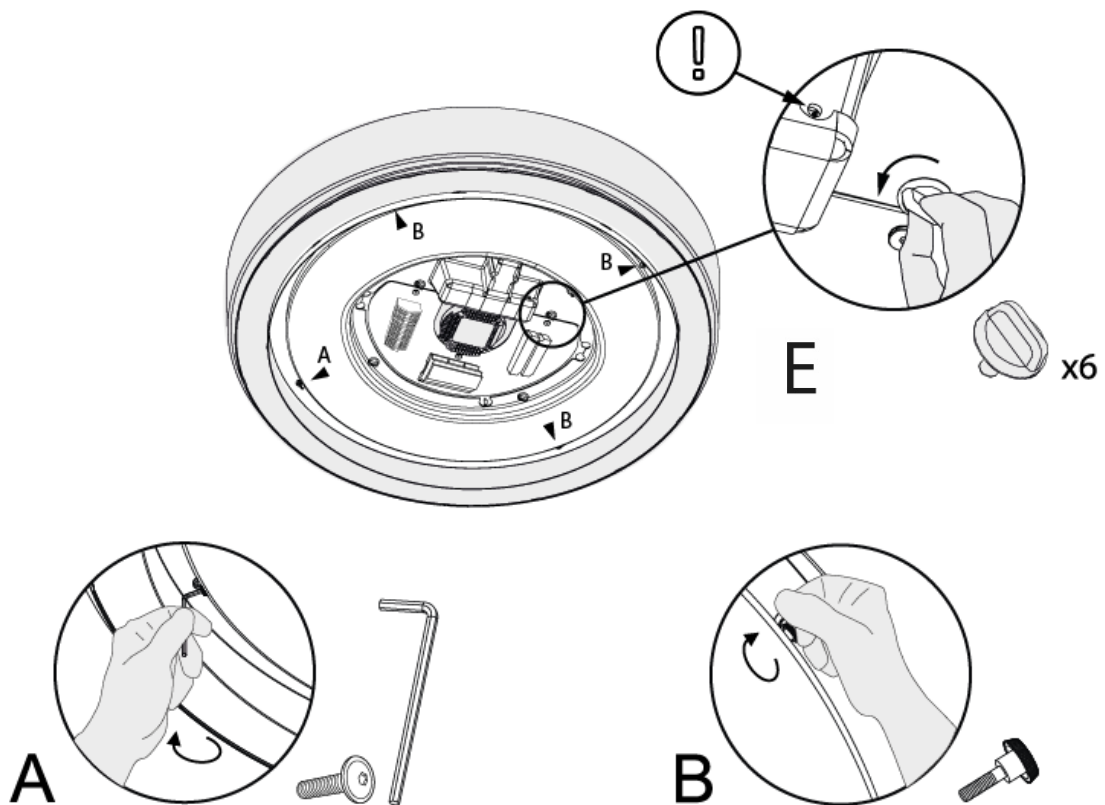

FIG. 15.4 DISASSEMBLING THE CONDENSATE TRAY

Empty the disassembled condensate tray of any condensate and clean it thoroughly. Rinse the filter marked at point [F] with water and clean it.

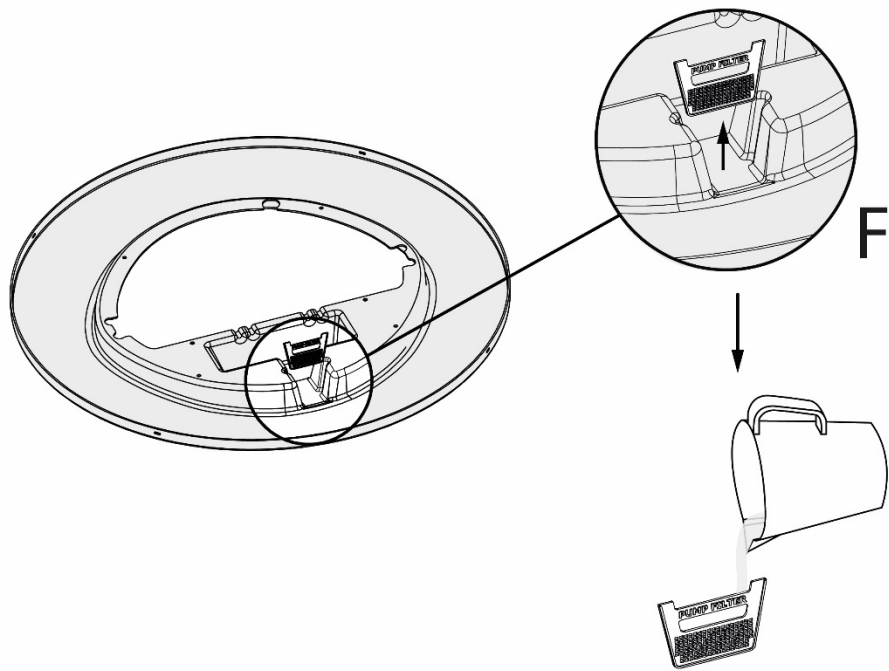

FIG. 15.5 CLEANING THE CONDENSATE TRAY

Disconnect the condensate pump from the power supply and detach the condensate discharge tube from the pump [G]. Slide the pump to the left as shown in the diagram [G] and rinse it under running water [H].

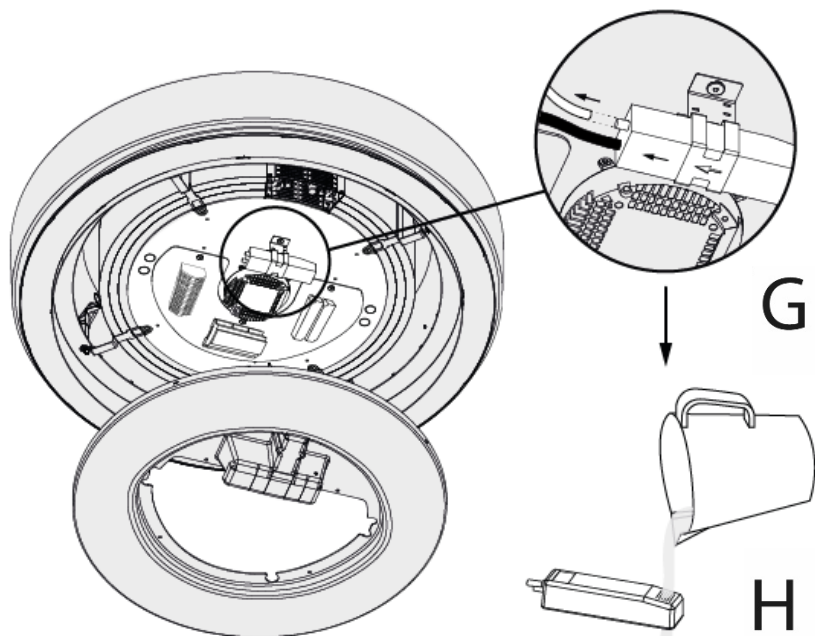

FIG. 15.6 CLEANING THE CONDENSATE PUMP

16. CONFORMITY WITH WEEE DIRECTIVE 2012/19/UE

Running a business without harming the environment and observing the rules of proper handling of waste electrical and electronic equipment is a priority for FLEXIHEAT

The symbol of the crossed out wheeled bin placed on the equipment, packaging or documents attached means that the product must not be disposed of with other wastes. It is the responsibility of the user to hand the used equipment to a designated collection point for proper processing. The symbol means that the equipment was placed on the market after August 13, 2005.



For information regarding recycling of waste electrical and electronic equipment, please contact your local distributor.

REMEMBER:

Do not dispose of used equipment together with other waste! There are financial penalties for this. Proper handling of used equipment prevents potential negative consequences for the environment and human health. At the same time, we save the Earth's natural resources, reusing resources obtained from the processing of equipment.

17. GENERAL WARRANTY TERMS

Please contact your dealer in order to get acquitted with the warranty terms and its limitation.

In the case of any irregularities in the device operation, please contact the manufacturer's service department.

**The manufacturer bears no responsibility for operating the device in a manner inconsistent with its purpose, by persons not authorised for this,
and for damage resulting from this!**

Made in EU

18. GENERAL OPERATING CONDITIONS

Operating conditions of the device

The Luna heating-cooling units are designed to provide thermal comfort in indoor spaces. The units are installed below the ceiling and feature automatic direction change of the air supply, ensuring even distribution of air regardless of the operating mode. Luna units are intended for indoor use and operate within a temperature range of 3°C to 45°C. The water heat exchanger can be supplied with water or a glycol solution with a concentration of up to 30% at fluid temperatures ranging from 6°C to 80°C and a maximum operating pressure of 16 bar.

Recommendations and required safety precautions

- Before performing any work on the unit, it is essential to familiarize yourself with the user manual.
- The unit should only be installed by qualified personnel with the appropriate credentials.
- During installation, electrical connection, connection to the heating medium, startup, repairs, and maintenance of Luna units, universally recognized safety regulations and standards must be followed.
- The unit must be installed in a stable, durable manner, following the instructions provided.
- The installation should allow for easy access to repairs, routine maintenance tasks, and safe disassembly of the unit.

Operation

- The Luna heating-cooling unit is designed for indoor operation in environments with a maximum dust concentration of 0.3 g/m³. The units contain elements made of EPP, plastic, and steel and should not be used in environments that may cause corrosion.
- The units should only be installed and operated under the conditions for which they are designed.
- The units should not be used in environments where oil mist is present.
- No objects should be placed on or hung from the unit's connection stubs.
- The unit must undergo periodic inspections. In the event of improper operation, it should be promptly turned off.
- A damaged unit should not be used. The manufacturer is not responsible for any damages that may occur from using a damaged unit.
- Electrical power must be disconnected during inspections or cleaning of the unit.
- Any modifications to the unit are prohibited. Interfering with the unit's design will void the warranty.

Periodic inspections

In order to maintain the proper technical condition of the device, it must undergo periodic inspections every 6 months. These inspections should be carried out exclusively by qualified personnel. During the inspection, the following tasks should be performed:

- Periodically (at least twice a year), check the condition of the heat exchanger for dirt accumulation. If cleaning of the heat exchanger is necessary, contact a suitably qualified technician
- Clean the condensate tray according to the instructions provided in the device manual.
- Clean the filter in the condensate tray following the instructions in the device manual.
- Clean the condensate pump according to the instructions in the device manual.
- After cleaning the condensate tray, place anti-clogging tablets in it to prevent the clogging of drain pipes and hoses. The tablet should be positioned as far away as possible from the drain point of the tray.
- Visually inspect the motor for proper operation. No cracking or grinding noises should be heard from the unit.
- Check the condition of the mounting components of the unit.
- Inspect the power cables of the unit for any mechanical damage.

① heating- cooling device
② Luna 2H, Luna 2HC, Luna 4HC;

③ 01.05.2023



DECLARATION OF CONFORMITY WE

④ The manufacturer hereby confirms that heating- cooling device:

- ② Luna 2H, Luna 2HC, Luna 4HC;

⑤ were produced in accordance to the following Europeans Directives:

1. **2006/42/WE** Machinery (MD)
2. **2014/30/UE** Electromagnetic Compatibility (EMC)
3. **2014/35/UE** Low Voltage Electrical Equipment (LVD)

⑥ and harmonized norms with above directives:

PN-EN ISO 12100	Machine Safety - General Principles of Design - Risk Assessment and Risk Reduction
PN-EN 60335-1	Household and similar electrical appliances - Safety - Part 1: General requirements
PN-EN 60335-2-30	Household and similar electrical appliances - Safety - Part 2-30: Particular requirements for room heaters
PN-EN 61000-3-2	Electromagnetic compatibility (EMC) - Limits. Limits for harmonic current emissions (equipment input current ≤16 A per phase)
PN-EN 61000-3-3	Electromagnetic compatibility (EMC) - Part 3-3: Limits - Limitation of voltage changes, voltage fluctuations and flicker in public low-voltage supply systems, for equipment with rated current ≤16 A per phase and not subject to conditional connection
PN-EN 61000-6-2	Electromagnetic Compatibility (EMC) - Part 6-2: Generic standards - Immunity for industrial environments
PN-EN 61000-6-4	Electromagnetic Compatibility (EMC) - Part 6-4: Generic standards - Emission standard for industrial environments

③ 01.05.2023

⑦ Product Manager

