



FLEXIHEAT UK LTD

www.flexiheatuk.com

01202 822221

Installation, Use and Maintenance Manual for model

R1K 50 RAIN

Premix condensing system boiler

only heating, suitable for outdoor installation

CE 0476

R1K 50 RAIN - RAD - ING - Manuale - 2103.1_SKM1.3_25-8_firm.L224G

SUMMARY

INTRODUCTION	4
--------------	---

1. INSTALLER SECTION 7

1.1. INSTALLATION	8
1.1.1. GENERAL INSTALLATION WARNINGS	8
1.1.2. BOILER LOCATION ENVIRONMENTAL REQUIREMENTS	8
1.1.3. REFERENCE LEGISLATION	9
1.1.4. BOILER OVERALL DIMENSIONS	10
1.1.5. JIG	10
1.1.6. FASTENING JIG	10
1.1.7. CIRCULATOR PREVALENCE/FLOW DIAGRAM	11
1.1.8. BOILER INSTALLATION	12
1.1.9. HYDRAULIC CONNECTION	14
1.1.10. CHARACTERISTICS OF THE WATER OF THE SYSTEM	15
1.1.11. SYSTEM FILLING	17
1.1.12. CONDENSATE DRAIN	18
1.1.13. ANTI-FREEZE PROTECTION	20
1.1.14. GAS CONNECTION	21
1.1.15. ELECTRICAL CONNECTION	21
1.1.16. POWER SUPPLY	22
1.1.17. OPTIONAL ELECTRICAL CONNECTIONS	23
1.1.18. FUME EXHAUST FITTINGS	26
1.1.19. INSTALLATION MODES	27
1.1.20. TYPES OF FUME EXHAUST SYSTEMS	29

2. SUPPORT CENTER SECTION 33

2.1. FIRST START-UP	34
2.1.1. PRELIMINARY OPERATIONS FOR FIRST START-UP	34
2.1.2. BOILER COMMISSIONING	35
2.1.3. CO2 VALUE CHECK AND CALIBRATION	36
2.1.4. ACCESSING AND PROGRAMMING THE PARAMETERS	37
2.1.5. DIGITECH CS PARAMETERS TABLE	39
2.1.6. ELECTRIC FAN FREQUENCY/HEAT CAPACITY DIAGRAM	48
2.2. MAINTENANCE	49
2.2.7. GENERAL MAINTENANCE WARNINGS	49
2.2.8. TECHNICAL DATA	50
2.2.8. TECHNICAL ASSEMBLY	52
2.2.9. HYDRAULIC BOARD	53
2.2.10. WIRING DIAGRAM	54

SUMMARY

2.2.11. ACCESSING THE BOILER	55
2.2.12. ACCESSING THE ELECTRONIC BOARD	56
2.2.13. SYSTEM EMPTYING	57
2.2.14. FAULT SIGNALLING CODES	58
2.2.15. ACTIVE FUNCTIONS SIGNALLING CODES	62
2.2.16. GAS CONVERSION	63

3. USER SECTION 65

3.1. USE	66
3.1.1. GENERAL USE WARNINGS	66
3.1.2. CONTROL PANEL	67
3.1.3. DISPLAY ICONS	68
3.1.4. INFO MENU DISPLAY DATA	69
3.1.5. START-UP	70
3.1.6. OPERATING MODE	70
3.1.7. INFORMATIONAL NOTE ON ANTI-FREEZE FUNCTION	71
3.1.8. FAULT SIGNALLING CODES	72
3.1.9. ACTIVE FUNCTIONS SIGNALLING CODES	74
3.1.10. COVER CLEANING	75
3.1.11. DISPOSAL	75

INTRODUCTION

WARNING

Before starting any operation it is mandatory to read this instruction manual, in relation to the activities to be carried out as described in each relevant section. Proper operation and optimal performance of the boiler are ensured by strict compliance with all the instructions given in this manual.

The installation, use and maintenance manual is an integral and essential part of the product and must be delivered to the user.

MANUAL USERS

The manual users are all those who install, use and maintain the boiler.

The boiler must be used and accessed only by qualified operators that fully read and understood the use and maintenance manual, paying particular attention to the warnings.

READING AND SYMBOLS OF THE MANUAL

To ease the understanding of this manual, recurrent symbols where used, in particular:

- › On the outer margin of the page is placed a thumb index indicating the type of user to which the instructions in that section address.
- › The titles are differentiated by thickness and size in accordance with their hierarchy.
- › The images contain important parts described in the text, marked with numbers or letters.
- › (See chap "chapter name"): this entry indicates another section in the Manual that you should refer to.
- › Device: this term is used referring to the boiler.



DANGER

It identifies an information related to a general danger that if not complied with, may cause serious personal damage or even death.



ATTENTION

It identifies an information that if not complied with may cause small or medium level lesions to the person or serious deterioration to the boiler.



WARNING

It identifies a precaution information that must be observed in order to avoid damaging the machine or parts of it.

MANUAL STORAGE

The manual must be carefully stored and replaced in case of deterioration and/or low legibility.

If you misplace the use and maintenance manual, you can request it from the Technical Support Centre giving the serial number and model of the boiler indicated on the plate placed on the right side of its casing.

MANUFACTURER WARRANTY AND RESPONSIBILITY

The technical and functional features of the device are ensured by its use in compliance:

1. with the use and maintenance instructions contained in the manuals accompanying the product, the content of which the customer certifies that he is aware;
2. with the conditions and purposes to which assets of the same type are intended.

For more information on the warranty validity, its duration, the obligations and the exemptions, please consult the First start-up certificate attached to this manual.

The manufacturer reserves:

- › the right to modify the tools and relative technical documentation without any obligation to third parties; neither will the company be held responsible for any inaccuracies in this handbook deriving from printing or translation errors;
- › the material and intellectual ownership of this manual and forbids its distribution and duplication, even partial, without prior written authorization.

PRODUCT CONFORMITY

Flexiheat declares that these gas boilers comply with the European Directives and with the requirements provided in the European standards below:

- › Eco-design Directive 2009/125 CE,

- › Energy labeling Directive 2010/30/CE,
- › Regulation EU 811/2013,
- › Regulation EU 813/2013,
- › Regulation EU 2016/426,
- › Electromagnetic compatibility Directive 2014/30/CE,
- › Performance Directive 92/42/CE,
- › Low voltage Directive 2014/35/CE.

The materials used such as copper, brass, stainless steel create a homogeneous, compact and functional assembly, easy to install and manage. In its simplicity, the boiler is equipped with all accessories necessary to render it a veritable independent heating unit. All boilers are tested and delivered with a quality certificate signed by the tester.

1. INSTALLER SECTION

The installation operations described in this section should be performed only by qualified personnel, having the appropriate technical training in the field for the installation and maintenance of components of civil and industrial domestic hot water production and heating plants.

1.1. INSTALLATION

1.1.1. GENERAL INSTALLATION WARNINGS



ATTENTION

This machine may be used only for the purpose for which it has been designed: heat water to a temperature below boiling point at atmospheric pressure. Any other use is considered wrong and dangerous. The manufacturer is excluded from any contractual or out of contract responsibility for damage caused to people, animals or property due to errors during installation.



ATTENTION

This boiler should be installed only by qualified personnel, having the appropriate technical training in the field for the installation and maintenance of components of civil and industrial domestic hot water production and heating plants.



ATTENTION

After having removed the packing, make sure the equipment is intact. In case of doubt, do not use the equipment and contact the supplier.

BEFORE INSTALLING THE BOILER, THE INSTALLER MUST MAKE SURE THAT THE FOLLOWING CONDITIONS ARE MET:

- › The device is connected to a heating plant and a water supply network appropriate for its power and performance.
- › The location must be properly vented through an air vent.
- › The air vent must be placed at floor level to prevent it from being obstructed, protected by a grid that does not hamper the useful section of passage.

- › The device is suitable for use with the type of gas available by checking the boiler data plate (placed on the inner side of the front casing).
- › Make sure that the tubes and couplings are perfectly sealed, without any gas leaks.
- › Make sure that the grounding system works properly.
- › Make sure that the electrical systems is suitable for the maximum power absorbed by the equipment, value indicated on the data plate.

1.1.2. BOILER LOCATION ENVIRONMENTAL REQUIREMENTS

The boiler has a thermal power over 35 kW and, therefore, it must be installed only into a heating unit.

The device's installation location should be vented due to the presence of threaded joints on the gas adduction line. The location should be therefore provided with vents as to ensure air exchange, with output grid in the natural accumulation area of eventual gas losses.



WARNING

DO NOT install the boiler in a technical compartment near a swimming pool or a laundry, to avoid that the combustion air is exposed to chlorine, ammonia or alkaline agents that may worsen the corrosion phenomenon of the heat exchanger. Failure to observe this caution will void the warranty of the heat exchanger.



WARNING

If the temperature in the boiler installation location goes below -10 centigrades, please fill the plant with anti-freeze liquid and insert and electrical resistances kit (see chapter 'ANTI-FREEZE PROTECTION').



WARNING

The manufacturer will not be held responsible for damages caused by incorrect installation not in conformity with the over mentioned instructions and not protected adequately from the freeze.

1.1.3. REFERENCE LEGISLATION

The installation must be realized according to the requirements of current legislation and in compliance with local technical regulations, according to the indications of the good technique.

2. INSTALLATION

1.1.4. BOILER OVERALL DIMENSIONS

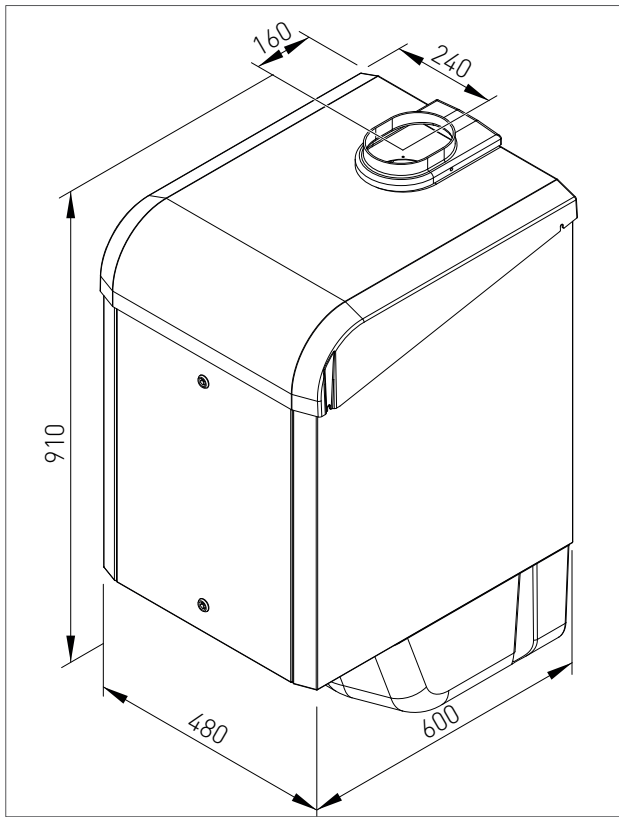

1.1.6. FASTENING JIG

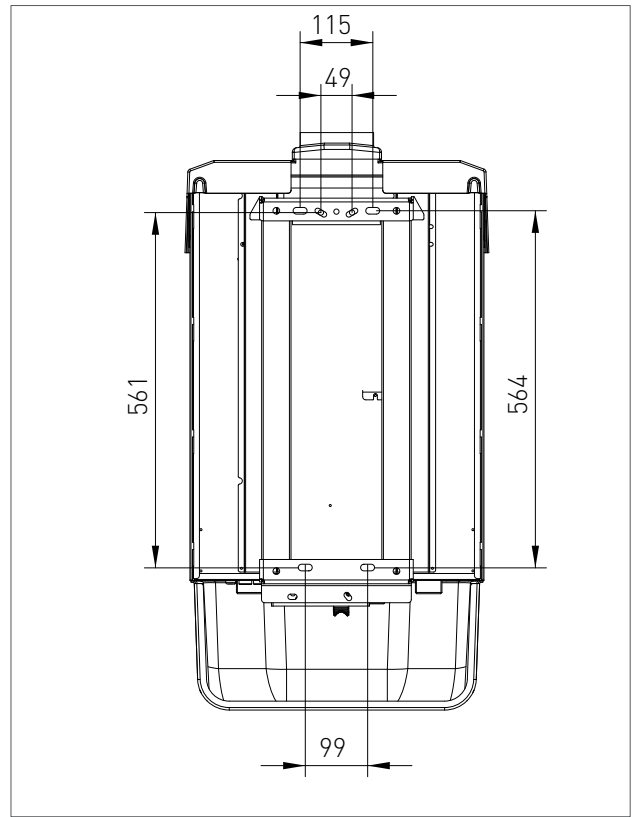

1.1.5. JIG

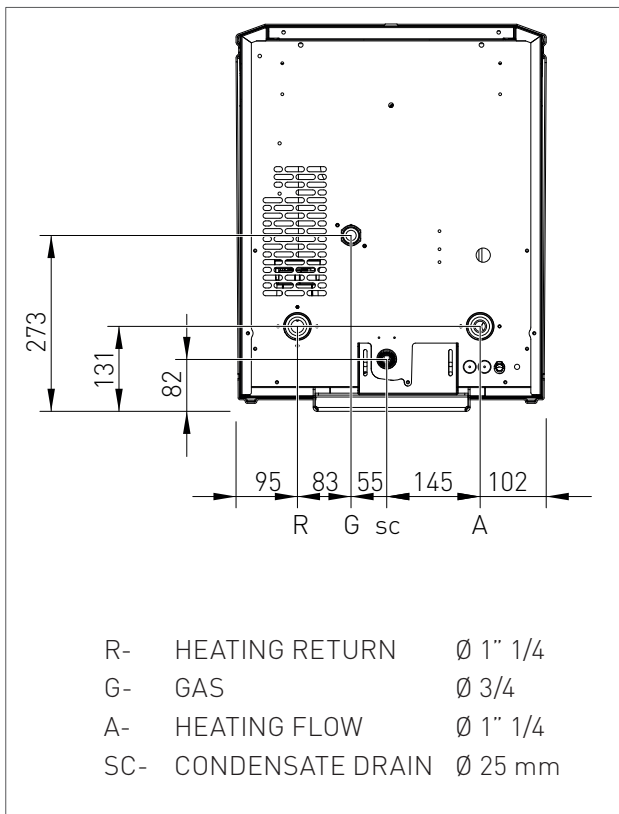

1.1.7. CIRCULATOR PREVALENCE/FLOW DIAGRAM

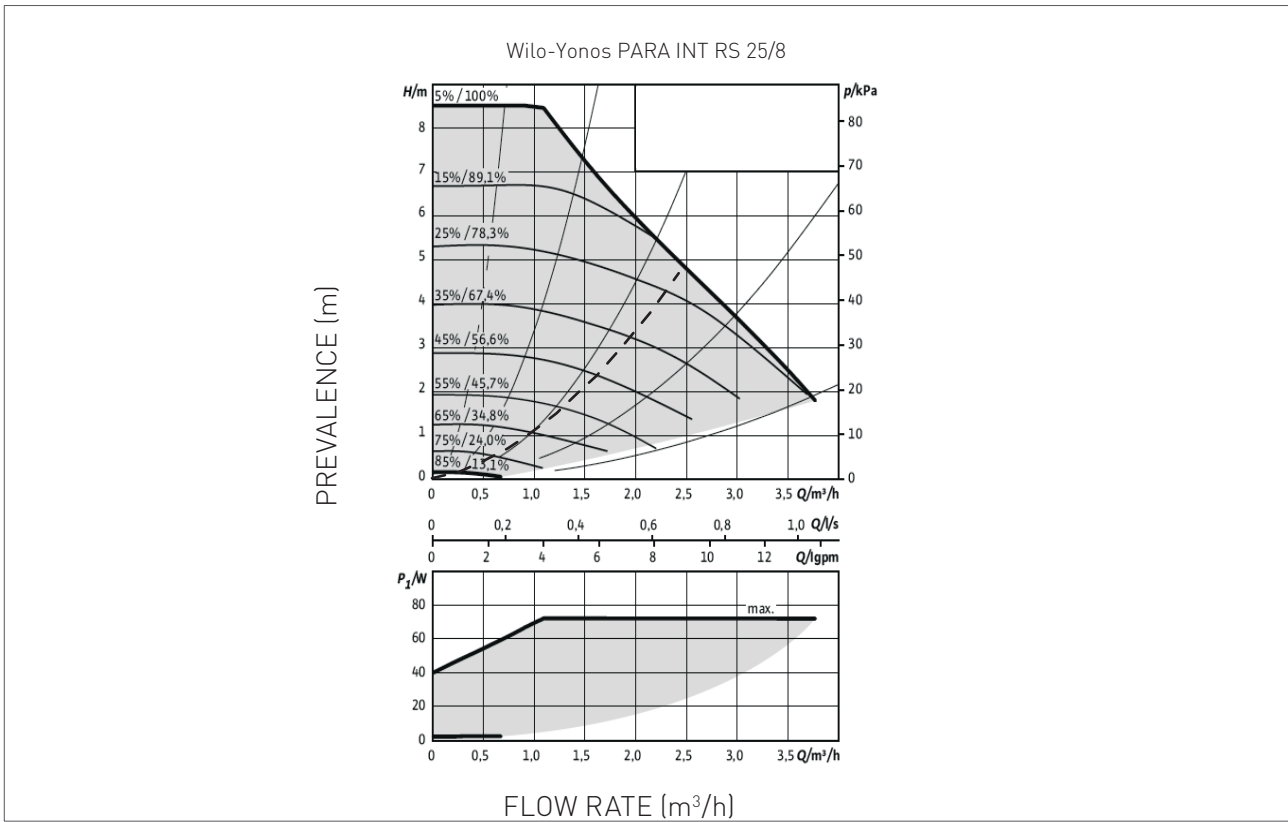

--- Appliance Loss

2. INSTALLATION

1.1.8. BOILER INSTALLATION

MINIMAL TECHNICAL SPACES

In order to allow the access inside the boiler for maintenance operations, you have to respect the minimum technical spaces indicated in figure 1.



WARNING

The incorrect slopes of the device can cause the incorrect discharge of condensate by means of the discharge duct with consequent condensate stagnation inside the condensate module.



WARNING

The boiler must be installed only on a vertical solid wall, able to sustain its weight.

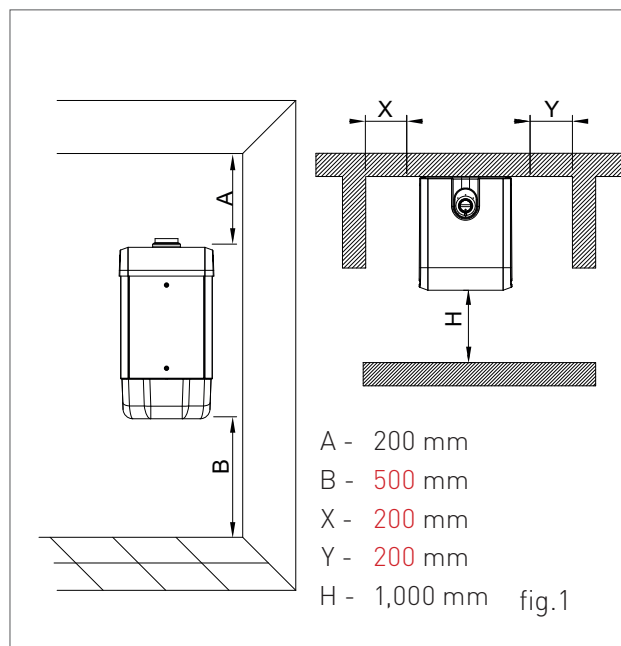

WALL INSTALLATION BY MEANS OF A FIXING FRAME

**WARNING**

In order to avoid condensate stagnations inside the condensate module, check that the boiler is slightly inclined towards the rear part (1-1.5°) in order to evacuate the condensate.

**WARNING**

The device must be installed only on a vertical solid wall, able to sustain its weight.

To facilitate the assembly, the boiler is equipped with a template and a frame that allow to prepare in advance the connections to the pipes with the possibility to install the boiler only when masonry works are completed. For assembly follow the instructions below:

1. With the help of a spirit level, fix the mounting template to the wall where you intend to install the boiler, mark the points to insert the $\varnothing 10$ dowel screws and points for the heating flow and heating return system's connections.
2. Make the holes and fix the frame to wall (Figure 1).
3. Hook the boiler using the slots on the frame (Figure 2).
4. unscrew the fixing screws of the lower bracket (fig. 3) ensuring the free sliding of the bracket towards the boiler;
5. adjust the inclination of the boiler (fig. 4) by sliding the lower bracket ensuring an inclination of the boiler, against the vertical, of about 1-1.5°.

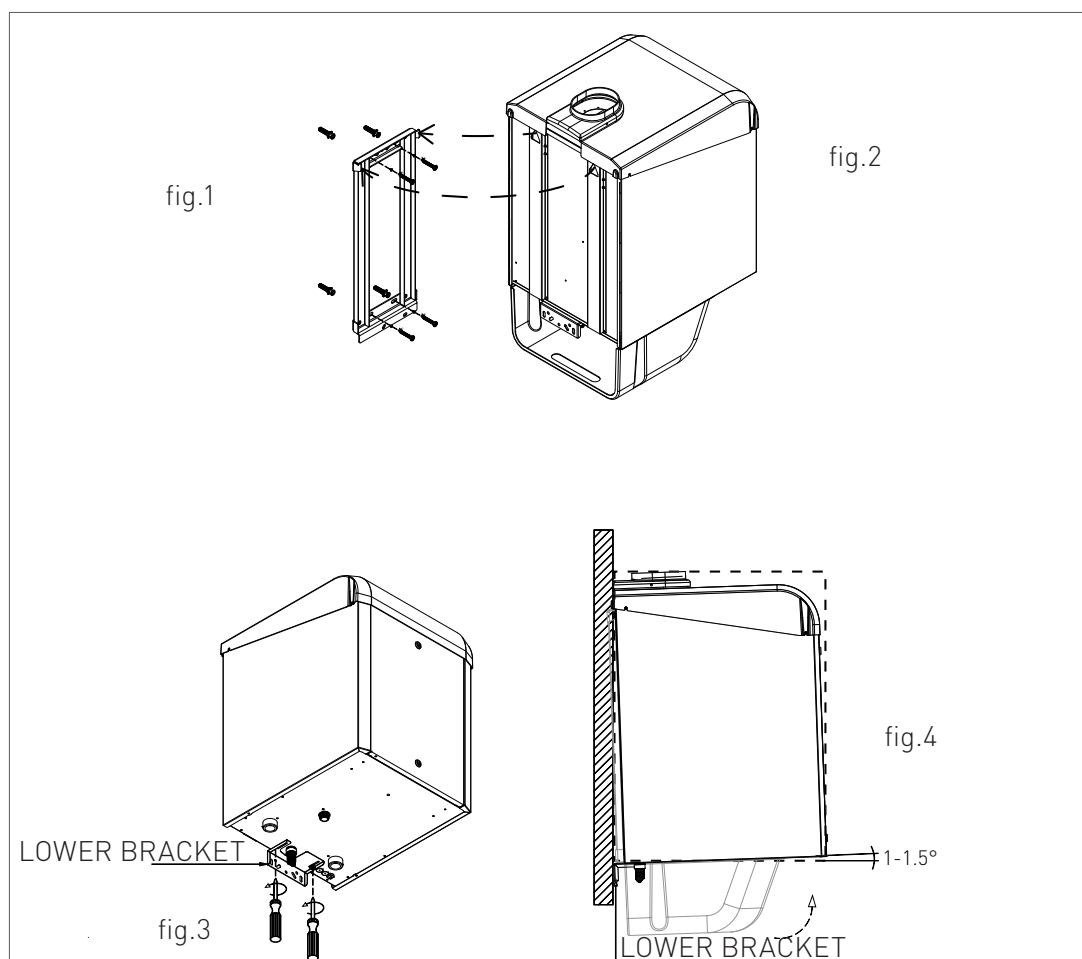

1. INSTALLATION

1.1.9. HYDRAULIC CONNECTION



DANGER

Make sure that the tubes of the water and heating plant are not used as grounding system for the electrical plant. There are not suitable for such use.



WARNING

To prevent voiding the warranty and to ensure the proper operation of the boiler, please wash the plant (if possible when hot) with suitable pickling or descaling solutions in order to remove the impurities coming from tubes and radiators.



WARNING

If the boiler is installed in a hydrostatic position lower than those of the user devices (radiators, fan coils, etc.), mount the shut-off valves on the domestic water heating circuit to ease the performance of the maintenance operations if it is necessary only to empty the boiler.



WARNING

When connecting the equipment to water supply, avoid excessive bending and recovery operations from any off axis positioning that may damage the tubes causing leaks, malfunction or early wear.



WARNING

In order to avoid any vibrations and noises, do not use tubes with small diameters or elbows with small radius and significant cut-off of the passage sections.



WARNING

Connect the boiler safety drains to a discharge funnel. The manufacturer is not responsible for any floods due to safety valve opening in case of plant overpressure.

DOMESTIC CIRCUIT

In order to prevent limestone build-up and damages to the domestic water heat exchanger, the hardness of the domestic supply water should not exceed 15 °f. However, please check the characteristics of the water used and install suitable treating devices.

The heat exchanger coil cleaning frequency depends on the hardness of the supply water and on the presence of solid residues or impurities inside the water that are often present in case of recently installed plants. Based on the characteristics of the infeed water, you should install suitable water treating devices, for residues presence please install a line filter.

The pressure of the cold infeed water should be between 0.5 and 6 bar. In case of greater pressure values, please install a pressure reducer upstream from the boiler.

HEATING CIRCUIT

In order to avoid any scale or deposits on the primary exchanger, the hardness of the heating circuit infeed water should not exceed 25 °f. However, please check the characteristics of the water used and install suitable treating devices.

This treatment is mandatory if frequent episodes of return water or partial or total emptying of the plant occur.



WARNING

In case the boiler is installed as part of a low temperature circuit, please install a safety thermostat on the heating flow, which can stop the boiler activity in case of high heating flow temperature. The company assumes no liability for damage caused to persons or for failure to comply with these instructions.

1. INSTALLATION

1.1.10. CHARACTERISTICS OF THE WATER OF THE SYSTEM

For a correct operation of the system, it is necessary to make sure that:

1. The system does not present losses or that the most obvious are at least eliminated;
2. If an automatic filling system is present, a litre meter must be installed in order to precisely know the extent of any losses;
3. The filling in of the system and the top ups are performed with softened water in order to reduce the total hardness. The water must also be treated in order to maintain the pH within the provided threshold so as to avoid corrosion phenomena.
4. Either on new systems or on replacements, the system must be fitted with efficient systems which ensure the elimination of the air and impurities: Y filters, micro impurity separators and micro bubbles of air separators;
5. Avoid draining the water of the system during the routine maintenance even if it is about apparently insignificant quantities: for example, in order to clean the filters, provide the system with adequate shut-off valves;
6. Always perform an analysis of the water of the system before opening the communication between the new generator and the system, in order to establish if the parameters present in the water indicate the need to fully drain the system, to use the water already present in the system or to chemically wash the system using utility water adding a detergent when it is suspected that the system might be dirty or particularly clogged and at the next loading with new treated water.

Water treatment

In order to preserve the integrity of the water-fume exchanger and to guarantee optimal thermal exchanges, it is necessary that the water of the primary circuit, circulating inside the exchanger of the condensate boiler, has the characteristics defined and constant in time. To obtain this, it is fundamental to perform a series of system preparation and maintenance operations such as:

- washing the system;
- check the characteristics of the water of the system;

The type of treatment to be performed will be chosen based on the characteristics of the water to treat, of the type of system and on the requested purity limits

Oxygen

A certain amount of oxygen always enters the system, both during the filling phase and during the use in case of reintegration or presence of hydraulic components without oxygen barriers. The reaction between the oxygen and the stainless steel creates corrosion and forms sludge. While the water fume exchanger is made of stainless steel, and therefore it is not subject to corrosion, the sludge created in the carbon steel system is deposited in the warm points, including the exchanger. This has the effect to reduce the heat capacity and thermally insulate the active parts of the exchanger, which might cause damages.

The precautions to limit the phenomena are:

- Mechanical systems: a deaerator combined with a sludge remover, correctly installed, reduce the quantity of oxygen circulating inside the system.
- Chemical systems: the additives allow the oxygen to dissolve in water.

Hardness

The filling and make-up water hardness brings a certain amount of limestone into the system. It attacks the warm parts of the exchanger, thus creating load losses and thermal insulation losses on the active parts. This phenomena can cause damages.

The filling and make-up water of the system, if it does not fall under the values indicated below, should be softened. Moreover, additives can be added in order to maintain the limestone into the solution. The hardness must be periodically checked and registered.

Acidity	7 < pH < 8.5	
Conductivity	< 400	µs/cm (at 25°C)
Chlorides	< 125	mg/l
Iron	< 0.5	mg/l
Copper	< 0.1	mg/l

If the above indicated limits are exceeded, a water must be chemically treated.

The type of treatment to be performed will be chosen based on the characteristics of the water to treat, of the type of system and on the requested purity limits.

1. INSTALLATION

1.1.11. SYSTEM FILLING



WARNING

For system filling use only clean tap water. In order to prevent limestone build-up and damages to the domestic water heat exchanger, the hardness of the domestic supply water should not exceed 15° Fr. However, please check the characteristics of the water used and install suitable treating devices.



WARNING

If the system is filled by adding ethylene glycol-type chemical agents you have to install on the loading system a hydraulic trip unit in order to separate the heating circuit from the domestic circuit.

Before powering up the boiler, fill the system as follows:

1. slightly loosen the cap of the jolly valve placed on the top of the condensing block to release the air from the top of the system (1-fig.1);
2. check that the jolly valves vent the air present in the system are not blocked;
3. connect a rubber pipe to the draining tap placed on top of the condensing heat exchanger (2-fig.1);
4. open the general domestic water input tap and load the system by exhaling all the air;
5. use pressure gauge present in the system to make sure that the system pressure reaches the design value;
6. after performing this operation, make sure that the loading tap is properly closed.
7. Open the air relief valves of the radiators and check the air removal process. When the water starts to leak close the radiators air relief valves.

8. If after performing these operations you observe a decrease of the water pressure inside the system, open once again the loading tap until the pressure gauge reaches the design pressure.

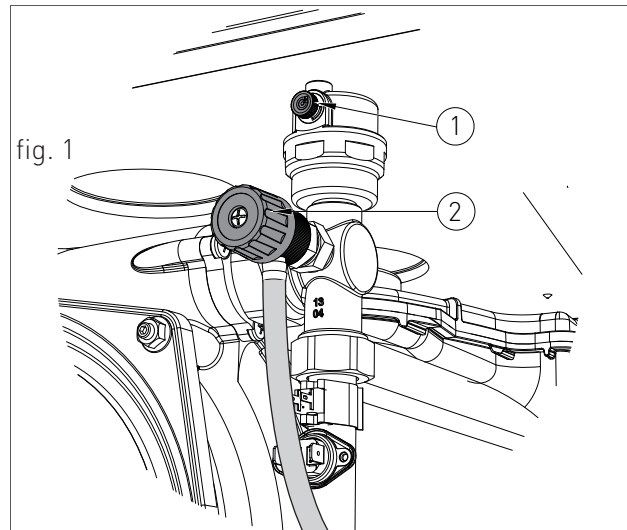

1. INSTALLATION

1.1.12. CONDENSATE DRAIN

FILLING THE CONDENSATE DRAIN SIPHON

Before starting the boiler you have to fill the condensate collection siphon in order to avoid fuel reflux through the siphon.

Fill the condensate collection siphon as follows:

- › Unscrew the screw "P" (fig. 1), extract the siphon and fill it with water up to the highest point "T" (fig. 1);
- › Connect the adequately prepared flexible condensate drain tube to a disposal system (it is necessary to neutralise the condensate if the material out of which the canal system where the condensate arrives is composed presents a corrosion risk; please see paragraph 'CONDENSATE NEUTRALISER'). The condensate can be drained directly in the sewerage system by inserting an easily serviceable siphon.



WARNING

After the first months of operation of the device, it is recommended to clean the condensate collection siphon from any deposits deriving from the first transit of the condensate inside the technical components of the boiler. Such deposits might cause a malfunction of the siphon.

CONDENSATE DRAIN

The boiler produces a significant quantity of condensate during operation. This condensate has an acid pH of 3-5. Observe the national standard in force and the local regulations for the disposal of the condensate produced by the boiler.

The designer, according to the power of the system and the intended use of the building, is bound to evaluate the acceptance of systems in order to neutralise the acid condensate.

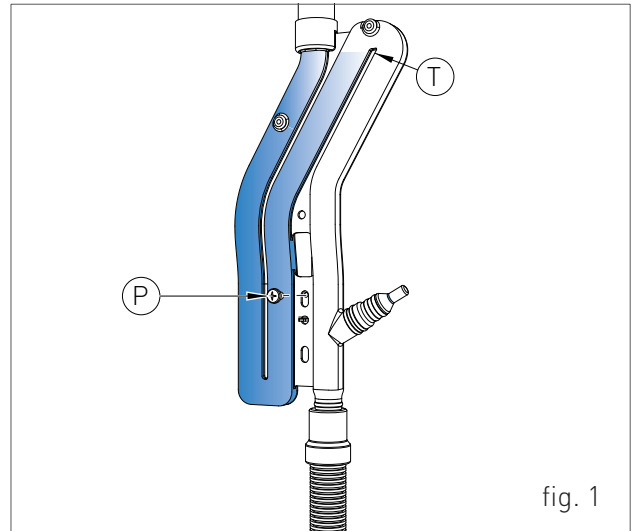

The system must be performed so as to avoid the freezing of the condensate. Before putting into operation the device, check the correct evacuation of the condensate.



WARNING

Before connecting the condensate collection siphon to the drain tube, check that the slope of the boiler is ensured according to the indications from chapter 'INSTALLATION OF THE BOILER'.



WARNING

Correctly connect the condensate collection siphon of the boiler to a draining system by adding the slope to the drain of the condensate of the fume exhaust duct. Where possible, it is recommended to perform such connection by means of a collection glass in order to check the correct discharge of the condensate avoiding stagnations that might cause dangerous returns of the condensate to the boiler.

In order to connect the condensate draining to the draining system, use only corrosion-resistant materials with an adequate diameter.

CONDENSATE NEUTRALISER

Assemble the condensate neutralisation box, fitted with granulate and active carbons for a treated power up to 350 kW (see fig.2). The device allows neutralising the condensate which is collected inside the boiler and/or in the fume discharge systems made of stainless steel, plastic, glass or ceramic.

The acid condensate, inserted into the neutralisation box, follows a mandatory path for two phases; the first one, filtration of nitrates and sulphates by means of active carbons contained in the first tube line, in the second one, the pH is increased.

The acidity of the condensate can be checked by using litmus paper in order to determine the pH. Then, the neutralised condensate can be transported into the sewage system.

MAINTENANCE

The pH parameters must be comprised between < 7 and 8.5 >.

Every six months, it is necessary to establish the PH of the treated condensate inside the neutraliser. Immerse a litmus paper (or a suitable digital tool) in the condensate near the tapped draining connection for about 2 seconds and thus lay it on a white paper. After about 30 seconds, it is possible to compare with the coloured scale. The neutral point is on the value 6.8-7; at a lower value, the condensate is acid, at a higher value, it is base].

If necessary, replace the active carbon and the reagent granulate.



1. INSTALLATION

1.1.13. ANTI-FREEZE PROTECTION

The boiler is protected against freezing thanks to the electronic board preparation with functions that start the burner and heat the concerned parts when their temperature goes below the minimum pre-set values, protecting the boiler up to an external temperature of -10 °C.

The device starts when the hot water temperature goes below 8 °C, automatically starting the burner until the heating flow water temperature reaches the 30°C and, in presence of a return sensor, until the heating return water temperature reaches the 20°C.

The system starts even if on the display appears "OFF", as long as the boiler is connected to the power (230 V) and gas supply.

For long periods of standby, please empty the boiler and the plant.

If the temperature goes below -10° centigrades, please fill the plant with anti-freeze liquid (CLEANPASS FLUIDO AG cod. 98716LA) and insert and electrical resistances kit (cod. 82259LP).

DILUTION PERCENTAGE OF CLEANPASS FLUIDO AG

ANTIFREEZE - ETHYLENE GLYCOL (%) VOLUME	TEMPERATURE FREEZING POINT (°C)
20	-7.5
30	-13
35	-18
40	- 22.5
45	-28
50	-33.5
55	-42
60	-50

RECOMMENDED MINIMUM PERCENTAGE OF GLYCOL : 20 %

1. INSTALLATION

1.1.14. GAS CONNECTION



DANGER

In order to connect the gas connector of the boiler to the supply pipe use a stop seal of an appropriate size and material. The use of hemp, teflon tape or similar materials is strictly forbidden.

BEFORE PERFORMING THE GAS CONNECTION, MAKE SURE THAT:

- › the gas adduction line complies with the standards and regulations in force;
- › the tubing's section suits the requested capacity and its length;
- › the tubing is equipped with all safety and control devices required by the standards in force;
- › the internal and external seals of the gas infeed plant are checked;
- › the device is suitable for use with the type of gas available by checking the boiler data plate (placed on the inner side of the front casing. If they do not match you must take the necessary measures to adapt the boiler to another type of gas (see chapter GAS TRANSFORMATION);
- › the gas supply pressure falls within the values indicated on the data plate.

1.1.15. ELECTRICAL CONNECTION



DANGER

The equipment is electrically safe only if it is properly connected to an efficient grounding system, performed in compliance with the safety standards in force. You should check this essential safety requirement. If in doubt, request an accurate check of the electrical system performed by qualified staff, as the manufacturer is not responsible for any damages caused by lack of grounding system.

- › Make sure that the electrical systems is suitable for the maximum power absorbed by the equipment, value indicated on the data plate.
- › make sure that the cables section is appropriate for the maximum power absorbed by the equipment and that it is however not lower than 1 mm².
- › The equipment works with alternating current of 230 V and 50 Hz. The electrical connection must be performed using an all-pole switch with an opening of at least 3 millimetres between contacts placed upstream from the device.



WARNING

Make sure that the phase and neutral cables connection is performed in compliance with the wiring diagram (see chapter POWER SUPPLY).



WARNING

It is strictly forbidden the use of adaptors, multiple plugs and/or extensions for the general power supply of the equipment from the electrical network.

1. INSTALLATION

1.1.16. POWER SUPPLY

To power the boiler connect the electrical cables to the terminal inside the control panel as follows:



DANGER

Cut off the voltage from the main switch.

- > remove the boiler's front casing (refer to chapter ACCESSING THE BOILER).
- > loosen the two screws and remove the plate "A" (see fig. 1).
- > after removing the plate, connect the electrical cables to terminal "B" (see fig. 1):
 - the yellow/green cable to the terminal marked with grounding symbol "⊕".
 - the blue cable to the terminal marked with "N".
 - the brown cable to the terminal marked with "L".

After performing these operations, remount plate "A" and the front casing.

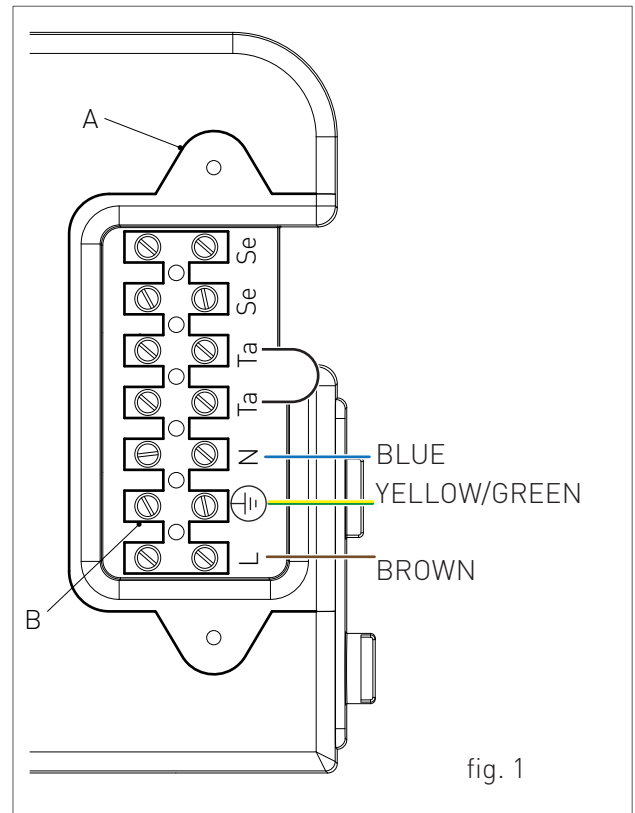

1. INSTALLATION

1.1.17. OPTIONAL ELECTRICAL CONNECTIONS

The cables should be inserted inside the boiler using the cable glands 'P1' and 'P2' placed under the board (see fig. 1). Make a hole on the cable gland, smaller than the cable diameter, to make sure that the air cannot pass through.

To wire the optionals below:

- **(SE) EXTERNAL TEMPERATURE PROBE COD. 73518LA**

- **(TA) ENVIRONMENT THERMOSTAT**

- **(CR) REMOTE CONTROL OPEN THERM COD. 40-00017**

use the terminal placed inside the control panel as follows:



DANGER

Cut off the voltage from the main switch.

- › remove the front casing of the boiler (see chapter ACCESSING THE BOILER); unscrew the screws and remove plate "A" (see fig. 2).

- › After removing the plate, connect the electrical cables to terminal "B" (see fig. 2):

- For the external temperature Probe connect the two non-polarized conductors to the Se-Se contacts.
- For the environment Thermostat or Remote control, first remove the bridge on the Ta-Ta contacts and then connect the two non-polarized conductors to the Ta-Ta contacts.

Any thermostat or controllers that are connected to the T1/T2 connections, must be Volt Free type , or you must use a volt free contact if you are using a controller or stat with voltage, prior to the connection points.

After performing these operations, remount plate "A" and the front casing.

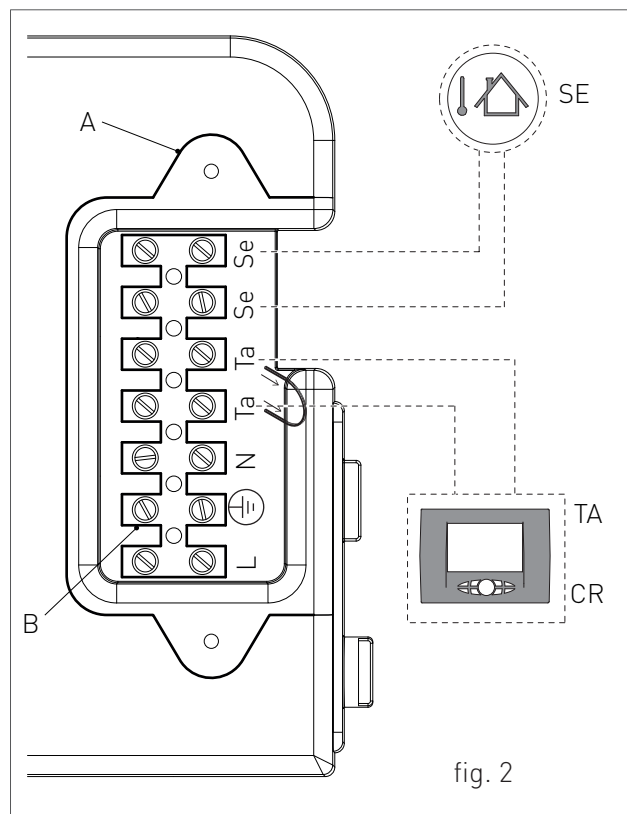
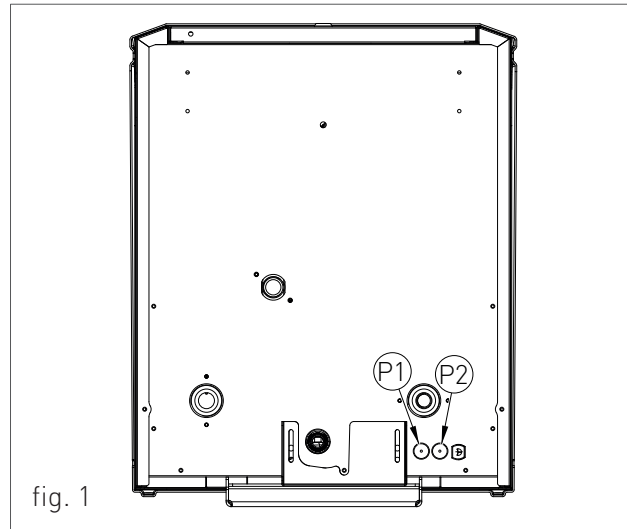

NB: In case of simultaneous presence of external probe and remote control, the modulation board only sends the external temperature value to the remote device without using it for modulation. The communication between board and remote control takes place independently from the boiler's operating mode and after establishing the connection, the used interface on the board is disabled and the display shows the symbol .

1. INSTALLATION

To wire the optionals below:

- (TP) EXCLUSION OF THE D.H.W. OR HEATING CIRCUIT VIA CLEAN CONTACT (SEE EXPLANATION IN THE PARAGRAPH 'EXCLUSION VIA CONTACT (TP)')
- (CT) TELEPHONE DIALER OR AIR PRESSURE SWITCH (SEE CONTACT MANAGEMENT IN THE PARAMETER P36)
- BUS 0-10V
- (SVZ) CONTROL BOARD FOR AREA VALVES AND AUXILIARY RELAY CONNECTED TO A REMOTE CONTROL COD. 65-00030
- (AG) AUXILIARY RELAY FOR GENERIC DEVICE. MAXIMUM CURRENT 3A WITH 250VAC (SEE RELAY MANAGEMENT AT PARAMETER P34)

use the electronic board placed inside the control panel as follows:



DANGER

Cut off the voltage from the main switch.

- > remove the boiler's front casing (refer to chapter ACCESSING THE BOILER).
- > remove the crankcase of the control panel (see chapter ACCESSING THE ELECTRONIC BOARD).
- > after removing the crankcase, connect the items below to the electronic board (see fig. 1):

After performing these operations, remount the crankcase and the front casing.

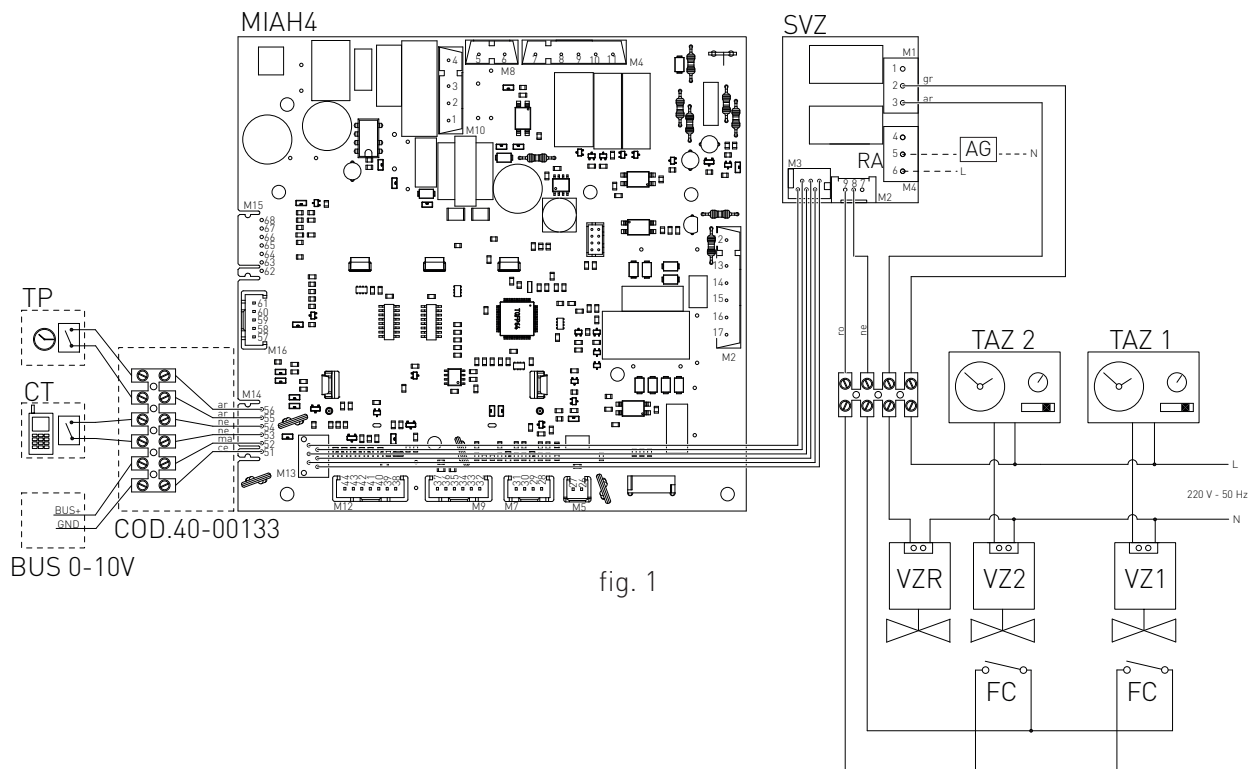

fig. 1

- RA: AUXILIARY RELAY
- TAZ1: ENVIRONMENT THERMOSTAT AREA 1
- TAZ2: ENVIRONMENT THERMOSTAT AREA 2
- VZ1: AREA 1 VALVE
- VZ2: AREA 2 VALVE
- VZR: REMOTE CONTROLLED AREA VALVE

- FC: AREA VALVES LIMIT SWITCH
- GR: GREY
- AR: ORANGE
- NE: BLACK
- MA: BROWN
- CE: LIGHT BLUE
- R0: RED

EXCLUSION VIA CONTACT (TP)

In case there is a tank clock or a temperature thermostat connected on contacts n.55-56 of the M14 terminal board on the P.C.B., when the contact (TP) is closed, one of the following functions or requests can be excluded:

FAST H2O FUNCTION – if parameter P01 value is set to '0' or '1' (see chapter 'DIGITECH CS PARAMETERS TABLE') and FAST H2O function is active, the function is deactivated when closing the contact.

D.H.W. REQUEST – if parameter P01 value is set to '0' or '1' and parameter P17 value is set to '1' (see chapter 'DIGITECH CS PARAMETERS TABLE'), the burner ignition request in D.H.W. mode is disabled, when closing the contact. If FAST H2O function is active, the function is deactivated when closing the contact.

TANK RESTORATION – if parameter P01 value is set to '2' or '3' (see chapter 'DIGITECH CS PARAMETERS TABLE'), the tank restoration function is deactivated, when closing the contact. Upon D.H.W. request through flow-switch, the boiler activates in instantaneous mode.

HEATING REQUEST – if parameter P01 value is set to '5' (see chapter 'DIGITECH CS PARAMETERS TABLE'), the burner ignition request in heating mode is disabled, when closing the contact (even if the request comes from a connected room thermostat or remote control).

1. INSTALLATION

1.1.18. FUME EXHAUST FITTINGS



WARNING

In order to ensure proper operation and efficiency of the device you have to connect the boiler fume exhaust fitting to the fume exhaust duct using appropriate polypropylene flue fittings for condensing boilers. It is recommended to install discharge systems



WARNING

You cannot use traditional flue fittings for the discharge ducts of the condensing boilers, nor vice versa.



WARNING

For fumes exhaust and condensate collection, please follow the technical standards in force.

- › For all discharge ducts, with regard to the fumes path, you should provide an uphill slope (outwards) so as to favour the reflux of the condensate towards the combustion chamber, suitably realized to collect and drain acid condensate.
- › For all air suction ducts, with regard to the air path, you should provide an uphill slope (towards the boiler) so as to avoid the protrusion inside the duct of rain water, dust or foreign objects.
- › In case of horizontal co-axial system installation, correctly place the horizontal co-axial terminal suitably realized to respect the slopes inside the fumes duct and to protect the air suction duct from adverse weather conditions.
- › In order to discharge the fumes through a fumes exhaust duct carefully follow the technical standards in force.
- › Make sure that the discharge tube does not protrude inside the fumes exhaust duct, stop before it reaches the inner surface of the latter.

- › The discharge duct must be perpendicular with the opposite internal wall of the chimney or of the fumes exhaust duct (fig. 1).

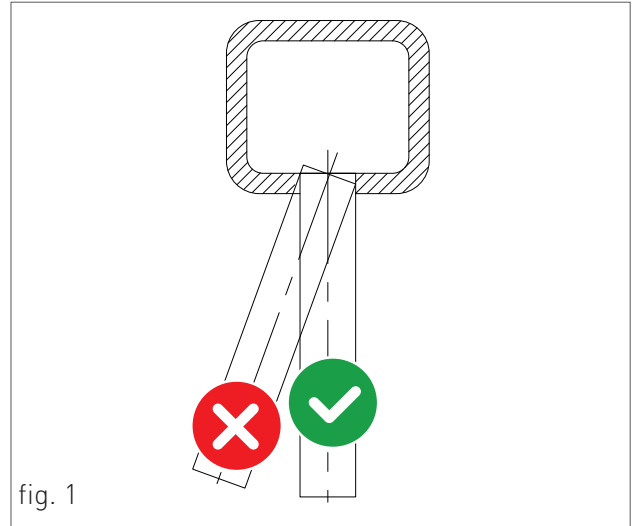
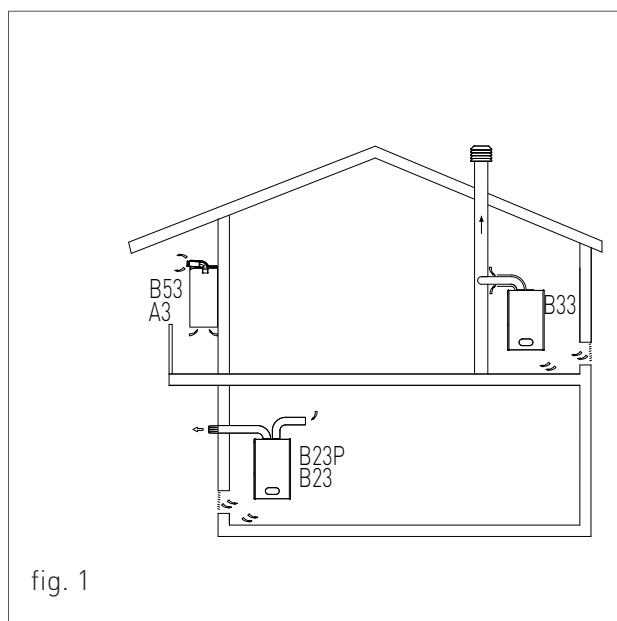

fig. 1

1.1.19. INSTALLATION MODES

For this type of boiler are available the following fumes discharge configurations: A3, B23, B23p, B33 and B53 (see Fig. 1).

- › A3- Outdoor suction and outdoor discharge.
- › B23- Indoor suction and outdoor discharge.
- › B23P- Indoor suction and outdoor discharge, with exhaust system operating under pressure.
- › B33- Indoor suction and fumes exhaust duct discharge.
- › B53- Indoor suction and outdoor discharge through own fumes exhaust duct.



DISCHARGE OF COMBUSTION PRODUCTS FOR B-TYPE DEVICES

The gas devices, provided with connection for fumes exhaust tube, must be directly connected to efficient chimneys or fume exhaust ducts: only if these are missing you can discharge the combustion products directly through the wall.

The connection to the chimney or to the fume exhaust ducts must respect the following requirements:

- Be sealed and realised in materials suitable to resist normal mechanical stress, heat, the action of combustion products and any condensate forming;
- have no more than three changes in direction, including the chimney and/or fume exhaust duct inlet connection, made with internal angles greater than 90°. The changes in direction must be made only by using curved elements;
- have the axis of the inlet end perpendicular to the internal wall opposite to the chimney or fume exhaust duct;

1. INSTALLATION

- have, along its entire length, a section equal to or greater than that of the connection of the device discharge tube;
- have no shut-off devices (shutters).
- for direct external discharge there must be no more than two changes in direction.

LOCATIONS VENTING FOR B-TYPE DEVICES

The locations in which are installed gas devices must be vented so as to ensure the amount of air necessary for a regular combustion and for location ventilation. The natural air intake must take place directly through:

- permanent openings on the external walls of the location (windows);
- single or collective, ramified ventilation ducts.

The openings on the external walls of the location must respect the following requirements:

- have a net overall free passage section of at least 6 cm^2 for every kW of heat capacity installed with a minimum of 100 cm^2 ;
- they must be realized so as to make sure that the opening inlets are not obstructed (neither indoors nor outdoors);
- they must be protected with grids, metal meshes, etc. so as to keep the useful section mentioned above.
- they must be placed at a height next to the floor level such as to allow proper operation of the combustion products discharge systems; if such position can not be obtained, please increase by at least 50% the section of the vents.

1.1.20. TYPES OF FUME EXHAUST SYSTEMS

KIT RAIN - Ø 80 HORIZONTAL POLYPROPYLENE PIPE. OUTSIDE INSTALLATION

It allows the flue discharge through the exhaust pipe and the air intake from the environment.

Suitable only for condensing boilers.

It allows the combustion flues discharge through a polypropylene pipe and the air exhaust directly from the hole situated on the room sealed chamber plate protected by a metal net.

PLEASE SEE THE MAXIMUM DISCHARGE LENGTH IN THE TABLE IN CHAPTER "TECHNICAL DATA".

The maximum discharge length (or linear reference length) can be calculated summing the length of the linear tube and that equivalent to each additional curve with respect to the first.

Subsequent addition of a curve is similar to adding a linear length of tube according to the indications below:

co-axial curve Ø80 to 90° = 1.5 m

co-axial curve Ø80 to 45° = 0.8 m

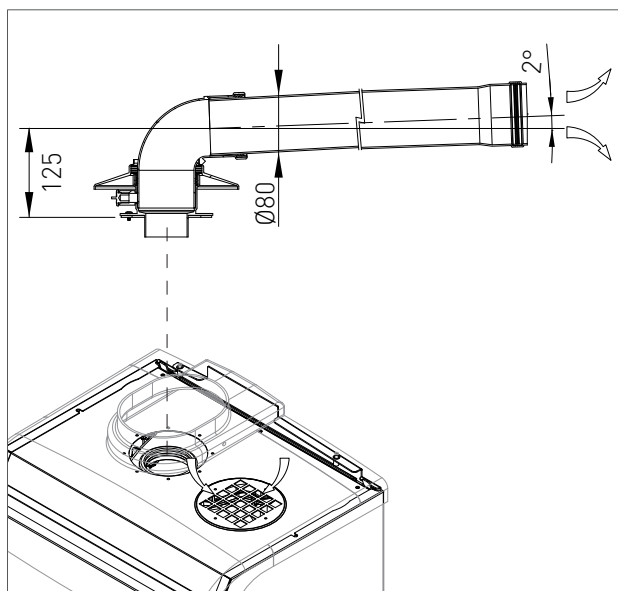

1. INSTALLATION

KIT RAIN L - Ø 80 VERTICAL POLYPROPYLENE PIPE. OUTSIDE INSTALLATION

It allows the flue discharge from the roof e and the air input from the environment.

Suitable only for condensing boilers.

It allows the combustion flues discharge through a polypropylene pipe and the air exhaust directly from the hole situated on the room sealed chamber plate protected by a metal net.

PLEASE SEE THE MAXIMUM DISCHARGE LENGTH IN THE TABLE IN CHAPTER "TECHNICAL DATA".

The maximum discharge length (or linear reference length) can be calculated summing the length of the linear tube and that equivalent to each additional curve with respect to the first.

Subsequent addition of a curve is similar to adding a linear length of tube according to the indications below:

co-axial curve Ø80 to 90° = 1.5 m

co-axial curve Ø80 to 45° = 0.8 m

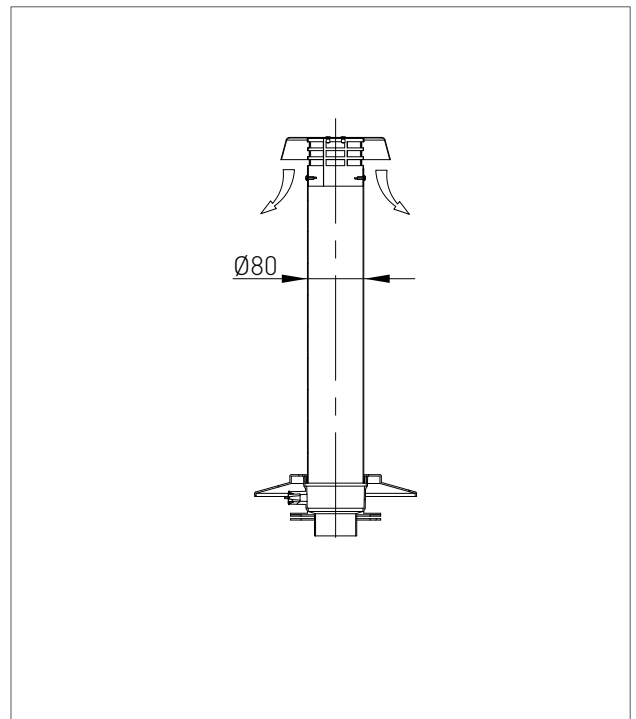
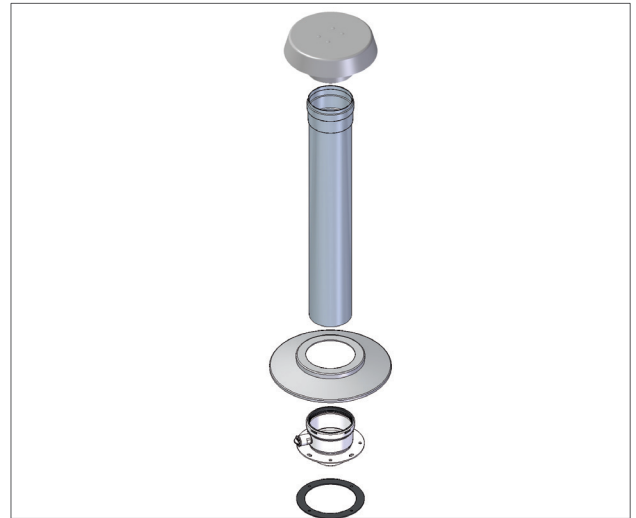

**VERTICAL FLUE PIPE Ø 80 - STAINLESS STEEL
FOR OUTDOOR INSTALLATION**

For a vertical flue exhaust and air intake from the boiler installation site

It allows to exhaust the combustion gases by means of a pipe and to intake the air directly from the hole located onto the room sealed chamber top.

PLEASE SEE THE MAXIMUM DISCHARGE IN THE TABLE IN CHAPTER "TECHNICAL DATA".

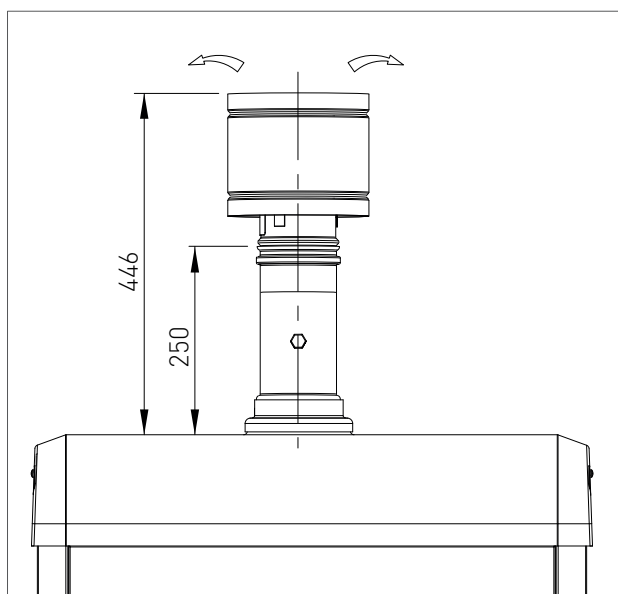

2. SUPPORT CENTER SECTION

All operations described below relative to first start-up, maintenance and replacement should be performed only by qualified personnel

2.1. FIRST START-UP

2.1.1. PRELIMINARY OPERATIONS FOR FIRST START-UP

The first start-up operations consist in checking the correct installation, adjustment and operation of the device. Proceed as follows:

- › check the inner system sealing in accordance with the indications provided by standard and regulations in forced;
- › check if the gas used is suitable for the boiler;
- › check if the gas capacity and relative pressures comply with those on the plate;
- › check the intervention of the safety device in case of lack of gas;
- › make sure that the device supply voltage corresponds with that on the plate (230 V – 50 Hz) and that the wiring is correct;
- › make sure that the grounding system works properly;
- › make sure that the combustion air adduction and fumes and condensate discharge take place properly in compliance with the Local and National Laws and Standards in force;
- › make sure that the fumes discharge tube and its connection to the fume exhaust duct comply with the requirements of the Local and National Laws and Standards;
- › make sure that the heating system gate valves are open;
- › make sure that there is no intake of gaseous products within the system;
- › make sure that there are no flammable liquids or materials near the device;
- › open the boiler gas tap and make sure that there are no gas leaks upstream from the device (the burner gas connection must be checked while the machine is running);
- › in case of new installation of the gas supply network, the air inside the tubes may block the device at its first start-up. You might have to repeat the start-up procedure to purge all the air inside the tube.

2.1.2. BOILER COMMISSIONING



WARNING

Make sure that the system is correctly filled.

Proceed with boiler commissioning as follows:

Make sure the gas feed valve is switched off

- › Power the boiler.

THE START-UP SYSTEM WILL AUTOMATICALLY ACTIVATE THE SYSTEM AIR RELIEF CYCLE FUNCTION DISPLAYED ON SCREEN WITH CODE "F33" (ONLY AT FIRST START-UP WILL LAST FOR 5 MINUTES*). When function "F33" is active, the pump is enabled and the burner start-up request is disabled. The boiler can work normally only after completing the operation.

- › Make sure the circulating pump is unblocked.
- › If it should be blocked, wait for the circulating pump to activate the automatic reset (lasting 3 min.)
- › If the circulating pump should be still blocked, activate the circulating pump automatic reset again (further 3 minutes), and switch off the power supply and switch it on again.
- › Open the gas tap.
- › Use the button  to select the desired operation mode. If the symbol is displayed fixed, it means that the function has been activated.
- › The burner will start as soon as the thermostat contact is closed ;
- › If the flame is missing, the board will repeat the start-up operations after post-ventilation (20 seconds).
- › You might have to repeat the start-up operation several times to release all the air inside the gas

tube. Before repeating the operation, wait at least 5 seconds from the last start-up attempt and unlock the boiler from "E01" error code by pressing the Reset  key.

(*) The boiler performs the system venting cycle function (5 minutes) only during the first starting. After every water pressure reset the boiler will automatically perform a reduced system venting cycle (2 minutes). During this function the display shows F33 code. The correct boiler operation will be allowed only after this operation has been completed.

2.1.3. CO₂ VALUE CHECK AND CALIBRATION



WARNING

The CO₂ value should be checked with the casing assembled, while the gas valve should be adjusted with the casing open.

To check and calibrate the CO₂ value to minimum and maximum heating power proceed as follows for every single unit:

FOR MINIMUM HEATING POWER

- › Activate the chimney sweep function (F07) by holding for 7 seconds the key 'R' (the maximum time of the function is 15 minutes).
- › Insert the fumes analyser probe in the suitable 'PF' fumes inlet (fig. 1), then make sure that the CO₂ value complies with the indications in "Technical data", otherwise unscrew the protection screw 'A' (fig. 2) and adjust using a 4 Allen wrench the screw '2' (fig. 2) of the Off-Set adjuster. To increase the CO₂ value, turn the screw clockwise and vice-versa if you want to decrease it. Once completed the adjustment, tighten the protection screw 'A' (fig. 2) on the Off-Set adjuster.

FOR MAXIMUM HEATING POWER

- › Press the key '⊕' of the heating (🔥) in order to calibrate the maximum heating power.
- › Make sure that the CO₂ value complies with the requirements indicated in chapter "Technical data", otherwise adjust using screw '1' (fig. 2) of the gas flow adjuster. To increase the CO₂ value, turn the screw anti-clockwise and vice-versa if you want to decrease it.
- › After each adjustment variation on screw '1' (fig. 2) of the gas flow adjuster you have to wait for the boiler to stabilize itself to the set value (about 30 seconds).

- › Then press the key '⊖' of the heating (🔥) and make sure that the CO₂ value did not change to minimum, if changed repeat the calibration described in the previous paragraph.
- › Deactivate the chimney sweep function by switching the boiler to the 'OFF' operating mode using the button (🔌).

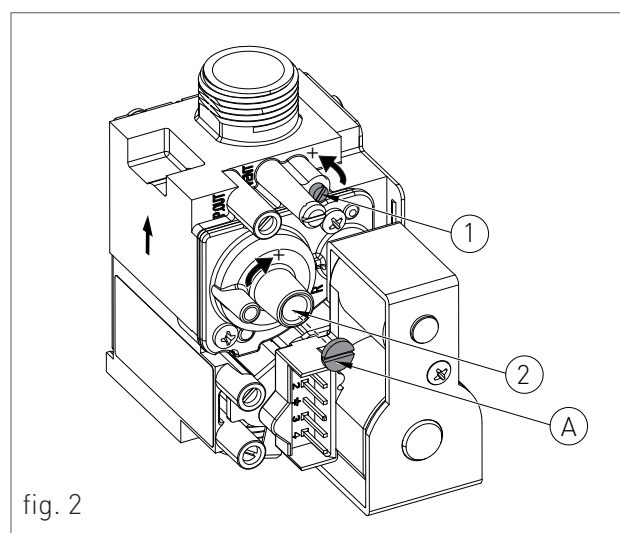
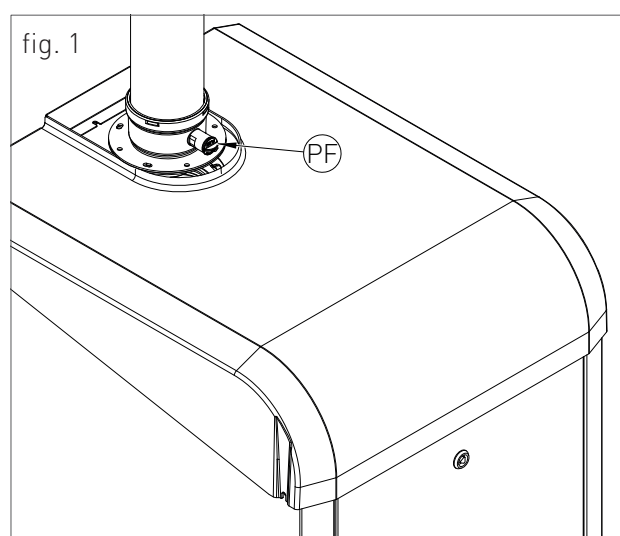





2.1.4. ACCESSING AND PROGRAMMING THE PARAMETERS

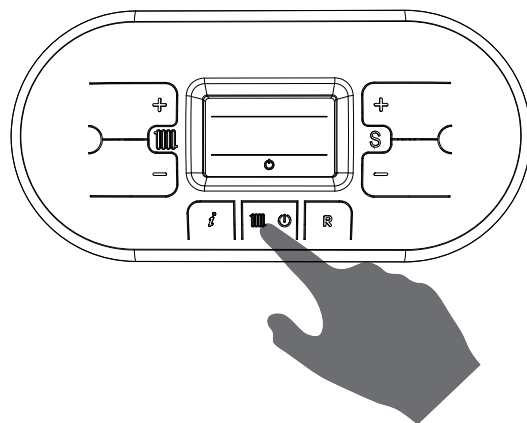

To access the parameters menu and adjust their values, follow the procedure below:

1. Press the button  to select the OFF mode displayed using the symbol .

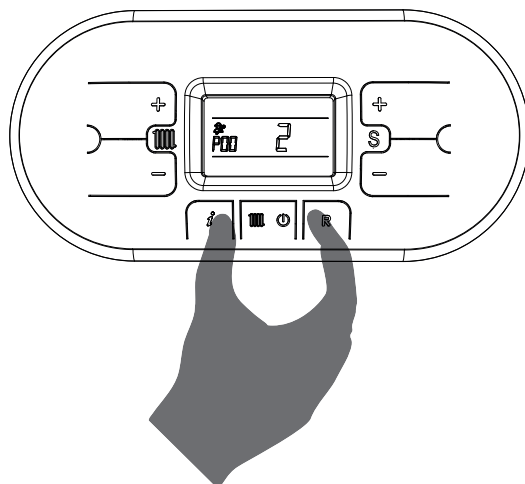

2. Hold at the same time the keys  and  until on the display appears the symbol  with the message 'P00', and release the keys  and .



3. Use the keys  and  of the heating circuit  to select the parameter to be edited.

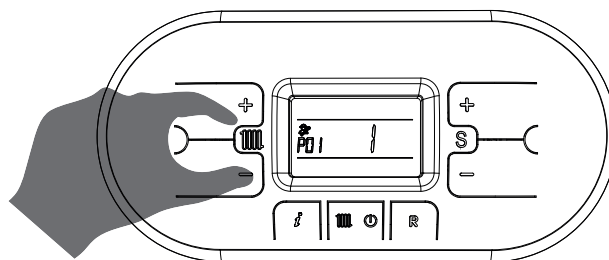

4. Use the keys '+' and '-' of the symbol 'S' to change the value of the parameter.

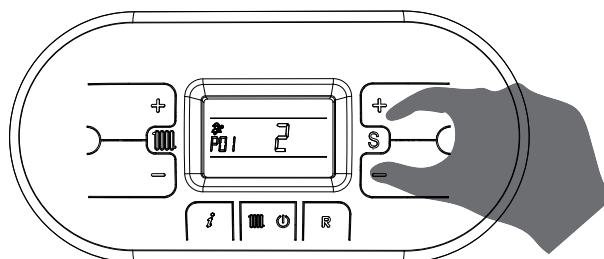

5. Press the key '⏻' to confirm the action and wait for the display to stop blinking, indication of the fact that the adjustment was implemented.

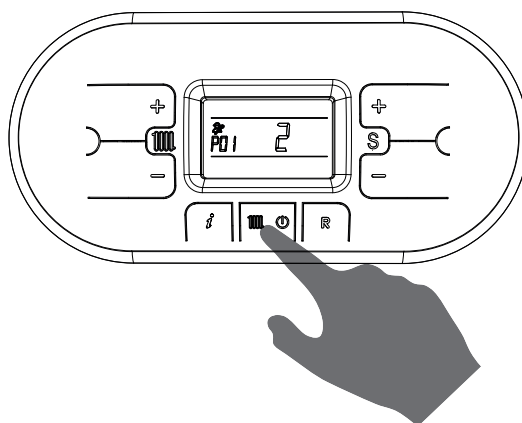

6. To exit the parameters menu, hold at the same time the keys 'i' and 'R' and wait for the symbol '⏻' to appear on the display.

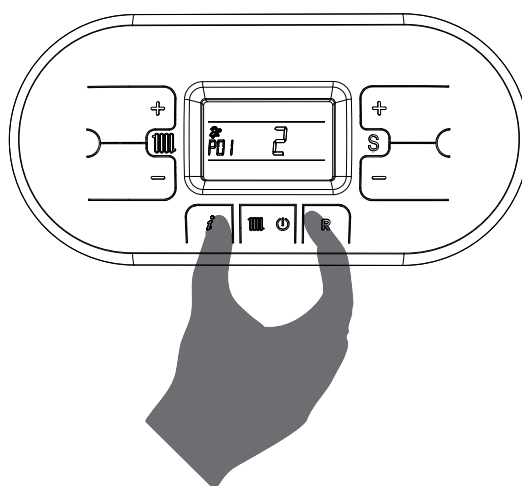

2. FIRST START-UP

2.1.5. DIGITECH CS PARAMETERS TABLE

PARAMETER	DESCRIPTION	RANGE	FUNCTION
P00	BOILER MODEL SELECTION	0 - 11	0 = 13 KW
			1 = 18 KW (HEAT.) / 24 KW (DOMESTIC)
			2 = 25 KW
			3 = 28 KW
			4 = 34 KW
			5 = 55 KW
			6 = 100 KW
			7 = R1K 18_24-R2K 24-R2KA 24 (IN ALL VERSIONS)
			8 = R1K 25_28-R2K 28-R2KA 28 (IN ALL VERSIONS)
			9 = R1K 34-R2K 34-R2KA 34 (IN ALL VERSIONS)
			10 = R1K 50
			11 = R1K 57 / R1K 60
P01	BOILER TYPE SELECTION	0 - 5	0 = INSTANTANEOUS R2K
			1 = INSTANTANEOUS RKR
			2 = ACCUMULATION IN CALDAIA
			3 = ACCUMULATION REMOTO
			4 = INSTANTANEOUS COMFORT - FAST H2O
			5 = HEATING ONLY

2. FIRST START-UP

PARAMETER	DESCRIPTION	RANGE	FUNCTION
P02	<p>GAS TYPE SELECTION</p> <p>ATTENTION: READ THE INSTRUCTION IN CHAPTER 'GAS TRANSFORMATION' BEFORE CHANGING THIS PARAMETER.</p>	0 - 1	<p>0 = METHANE</p> <hr/> <p>1 = LPG</p>
P03	<p>SETTING THE HEATING TEMPERATURE</p> <p>IN CASE THE BOILER IS INSTALLED AS PART OF A LOW TEMPERATURE CIRCUIT, PLEASE INSTALL A SAFETY THERMOSTAT ON THE HEATING FLOW, WHICH CAN STOP THE BOILER ACTIVITY IN CASE OF HIGH HEATING FLOW TEMPERATURE. THE COMPANY ASSUMES NO LIABILITY FOR DAMAGE CAUSED TO PERSONS OR FOR FAILURE TO COMPLY WITH THESE INSTRUCTIONS.</p>	0 - 1	<p>0 = STANDARD (30-80 °C) (SET BY DEFAULT)</p> <hr/> <p>1 = REDUCED (25-45 °C) FOR FLOOR SYSTEMS</p>
P04	<p>HEATING RUN-UP</p> <p>THROUGH THIS PARAMETER YOU CAN SET THE TIME, DURING START-UP PHASE, NECESSARY FOR THE BOILER TO REACH THE MAXIMUM SET POWER (ON THE HEATING SIDE).</p>	0 - 4	<p>0 = (DISABLED)</p> <hr/> <p>1 = 50 SECONDS</p> <hr/> <p>2 = 100 SECONDS</p> <hr/> <p>3 = 200 SECONDS (SET BY DEFAULT)</p> <hr/> <p>4 = 400 SECONDS</p>
P05	<p>ANTI-WATER HAMMER SELECTION</p> <p>ONCE THIS FUNCTION IS ENABLED, THE DHW CONTACT WILL BE DELAYED FOR A TIME EQUAL TO THE SET VALUE.</p>	0 - 20	<p>0 = DISABLED</p> <hr/> <p>1 - 20 = THE VALUE IS EXPRESSED IN SECONDS</p>
P06	<p>DOMESTIC CIRCUIT PRESERVATION FUNCTION (ONLY FOR INSTANTANEOUS BOILERS)</p> <p>THROUGH THIS PARAMETER YOU CAN PRESERVE THE CIRCULATOR THE DIVERTER VALVE IN DOMESTIC POSITION FOR A PERIOD OF TIME EQUAL TO THE POST-CIRCULATION (SEE PARAMETER P09), SO AS TO MAINTAIN THE SECONDARY EXCHANGER HOT.</p>	0 - 1	<p>0 = DISABLED (SET BY DEFAULT)</p> <hr/> <p>1 = ENABLED</p>
P07	<p>HEATING TIMING</p> <p>THROUGH THIS PARAMETER YOU CAN SET THE MINIMUM TIME FOR WHICH THE BURNER WILL BE TURNED OFF ONCE THE HEATING TEMPERATURE REACHED THE USER SET TEMPERATURE.</p>	0 - 90	<p>VALUE EXPRESSED IN MULTIPLES OF 5 SECONDS (PRE-SET AT 36 X 5 = 180 SECONDS)</p>

2. FIRST START-UP

PARAMETER	DESCRIPTION	RANGE	FUNCTION
P08	POST-CIRCULATION HEATING TIMING THROUGH THIS PARAMETER, IT IS POSSIBLE TO SET THE OPERATION TIME OF THE PUMP AFTER THE MAIN BURNER TURNS OFF DUE TO THE ENVIRONMENT THERMOSTAT.	0 - 90	VALUE EXPRESSED IN MULTIPLES OF 5 SECONDS (PRE-SET AT 36 X 5 = 180 SECONDS)
P09	POST-CIRCULATION DOMESTIC / STORAGE TIMING THROUGH THIS PARAMETER, IT IS POSSIBLE TO SET THE OPERATION TIME OF THE PUMP AFTER CLOSING THE TAP OR REACHING THE TEMPERATURE SET IN THE BOILER.	0 - 90	VALUE EXPRESSED IN MULTIPLES OF 5 SECONDS (PRE-SET AT 24 X 5 = 120 SECONDS)
P10	DOMESTIC FAN MINIMUM SPEED ADJUSTMENT THROUGH THIS PARAMETER YOU CAN SET THE FAN MINIMUM SPEED IN DOMESTIC PHASE, THAT CORRESPONDS TO THE MINIMUM BURNER POWER DURING A REQUEST TO OPERATE IN DOMESTIC MODE. THE VALUE IS PRE-SET BASED ON THE SET POWER (SEE PARAMETER P00) AND ON THE GAS TYPE (SEE PARAMETER P02)	SEE CHAPTER ' H E A T C A P A C I T Y D I A G R A M (KW) - ELECTRIC FAN FREQUENCY (HZ)'	THE VALUE IS EXPRESSED IN HERTZ (1HZ = 30 RPM)
P11	DOMESTIC FAN MAXIMUM SPEED ADJUSTMENT THROUGH THIS PARAMETER YOU CAN SET THE FAN MAXIMUM SPEED IN DOMESTIC PHASE, THAT CORRESPONDS TO THE MAXIMUM BURNER POWER DURING A REQUEST TO OPERATE IN DOMESTIC MODE. THE VALUE IS PRE-SET BASED ON THE SET POWER (SEE PARAMETER P00) AND ON THE GAS TYPE (SEE PARAMETER P02)	SEE CHAPTER ' H E A T C A P A C I T Y D I A G R A M (KW) - ELECTRIC FAN FREQUENCY (HZ)'	THE VALUE IS EXPRESSED IN HERTZ (1HZ = 30 RPM)
P12	HEATING FAN MINIMUM SPEED ADJUSTMENT THROUGH THIS PARAMETER YOU CAN SET THE FAN MINIMUM SPEED IN HEATING PHASE, THAT CORRESPONDS TO THE MINIMUM BURNER POWER DURING A REQUEST TO OPERATE IN HEATING MODE. THE VALUE IS PRE-SET BASED ON THE SET POWER (SEE PARAMETER P00) AND ON THE GAS TYPE (SEE PARAMETER P02)	SEE CHAPTER ' H E A T C A P A C I T Y D I A G R A M (KW) - ELECTRIC FAN FREQUENCY (HZ)'	THE VALUE IS EXPRESSED IN HERTZ (1HZ = 30 RPM)

2. FIRST START-UP

PARAMETER	DESCRIPTION	RANGE	FUNCTION
P13	<p>HEATING FAN MAXIMUM SPEED ADJUSTMENT</p> <p>THROUGH THIS PARAMETER YOU CAN SET THE FAN MAXIMUM SPEED IN HEATING PHASE, THAT CORRESPONDS TO THE MAXIMUM BURNER POWER DURING A REQUEST TO OPERATE IN HEATING MODE.</p> <p>THE VALUE IS PRE-SET BASED ON THE SET POWER (SEE PARAMETER P00) AND ON THE GAS TYPE (SEE PARAMETER P02)</p>	SEE CHAPTER ' H E A T C A P A C I T Y D I A G R A M (KW) - ELECTRIC FAN FREQUENCY (HZ)'	THE VALUE IS EXPRESSED IN HERTZ (1HZ = 30 RPM)
P14	<p>STARTING STEP ADJUSTMENT</p> <p>THROUGH THIS PARAMETER YOU CAN SET THE FAN SPEED DURING START-UP</p> <p>THE VALUE IS PRE-SET BASED ON THE SET POWER (SEE PARAMETER P00) AND ON THE GAS TYPE (SEE PARAMETER P02)</p>	SEE CHAPTER ' H E A T C A P A C I T Y D I A G R A M (KW) - ELECTRIC FAN FREQUENCY (HZ)'	THE VALUE IS EXPRESSED IN HERTZ (1HZ = 30 RPM)
P15	<p>ANTI-LEGIONELLA FUNCTION (FOR STORAGE BOILERS ONLY)</p> <p>THROUGH THIS PARAMETER YOU CAN ACTIVATE/DEACTIVATE THE "ANTILEGIONELLA" HEAT TREATMENT OF THE STORAGE TANK. EVERY 7 DAYS THE WATER TEMPERATURE INSIDE THE STORAGE IS HEATED BEYOND 60 °C THUS GENERATING A BURNING HAZARD. KEEP UNDER CONTROL SUCH DOMESTICH HOT WATER TREATMENT (AND INFORM THE USERS) TO AVOID UNFORSEEABLE DAMAGES TO PERSONS, ANIMALS AND PROPERTY. A THERMOSTATIC VALVE SHOULD BE INSTALLED AT THE DOMESTIC HOT WATER OUTLET TO AVOID ANY BURNS.</p>	0 - 1	0 = DISABLED 1 = ENABLED (PRE-SET BY DEFAULT ON STORAGE BOILERS ONLY)

2. FIRST START-UP

PARAMETER	DESCRIPTION	RANGE	FUNCTION
P16	<p>CLIMATE COMPENSATION CURVE (ONLY WITH EXTERNAL PROBE CONNECTED)</p> <p>YOU CAN CONNECT AN EXTERNAL TEMPERATURE PROBE (SEE CHAPTER 'ELECTRICAL CONNECTIONS') THAT AUTOMATICALLY CHANGES THE DELIVERY TEMPERATURE BASED ON THE EXTERNAL MEASURED TEMPERATURE. THE NATURE OF THE CORRECTION DEPENDS ON THE THERMO-ADJUSTMENT VALUE KD SET (SEE CHART).</p> <p>THE SELECTION OF THE CURVE IS DETERMINED BY THE MAXIMUM DELIVERY TEMPERATURE T_m AND THE MINIMUM EXTERNAL TEMPERATURE T_e TAKING INTO ACCOUNT THE HOUSE INSULATION DEGREE.</p> <p>THE VALUES OF THE DELIVERY TEMPERATURES T_m, REFER TO STANDARD SYSTEMS 30-80 °C OR FLOOR SYSTEMS 25-45 °C.</p> <p>THE SYSTEM TYPE CAN BE SET FROM PARAMETER P03.</p>	0 - 30	(SET BY DEFAULT AT 25) THE NUMBERING OF THE VALUE CORRESPONDS TO 'KD' CURVES ON THE CHART (SEE CHART BELOW).

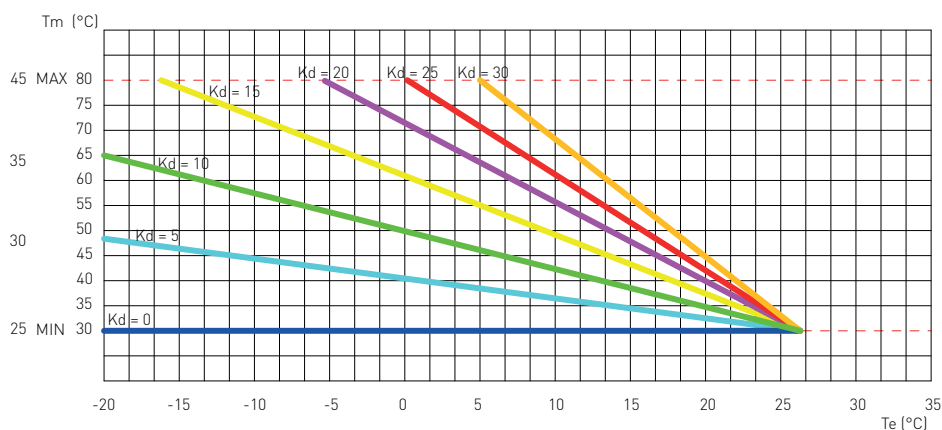

2. FIRST START-UP

PARAMETER	DESCRIPTION	RANGE	FUNCTION
P17	<p>DISABLEMENT OF DOMESTIC HOT WATER LINE BY MEANS OF SWITCH (ONLY FOR FAST BOILERS)</p> <p><i>(SEE EXCLUSION VIA CONTACT (TP) IN THE CHAPTER "OPTIONAL ELECTRICAL CONNECTIONS")</i></p> <p>BY ENABLING THIS PARAMETER IN THE PRESENCE OF A CONNECTION (FOR EXAMPLE A BOILER CLOCK OR A TEMPERATURE THERMOSTAT) ON BOILER CLOCK SWITCH ON THE BOARD, THE REQUEST FOR BURNER IGNITION ON THE DOMESTIC HOT WATER LINE WILL BE DISABLED UPON BOILER CLOCK SWITCH CLOSURE.</p> <p>EXAMPLE 1: WITH THE BOILER CLOCK SWITCH OPEN, UPON THE REQUEST FOR DOMESTIC HOT WATER, THE FLOW SWITCH AND THE BOILER WILL TURN ON.</p> <p>EXAMPLE 2: WITH THE BOILER CLOCK SWITCH CLOSE, UPON THE REQUEST FOR DOMESTIC HOT WATER, THE FLOW SWITCH AND THE BOILER WILL NOT TURN ON.</p>	0 - 1	<p>0 = DISABLED (SET BY DEFAULT)</p> <hr/> <p>1 = ENABLED</p>
P18	<p>ENABLING BUS INDUSTRIAL PILOTING 0 -10V</p> <p>THROUGH THIS PARAMETER YOU CAN ENABLE OR DISABLE THE BUS INDUSTRIAL INPUT 0-10 V TO SET THROUGH EXTERNAL BUS THE BURNER POWER OR THE DELIVERY TEMPERATURE.</p>	0 - 2	<p>0 = DISABLED (SET BY DEFAULT)</p> <hr/> <p>1 = TEMPERATURE CONTROL MODE</p> <hr/> <p>2 = POWER CONTROL MODE</p>
P19	<p>MINIMUM HEATING SETPOINT</p> <p>THROUGH THIS PARAMETER YOU CAN SET THE USER-ADJUSTABLE MINIMUM HEATING TEMPERATURE.</p>	20 - 40	THE VALUE IS EXPRESSED IN °C
P20	<p>MAXIMUM HEATING SETPOINT</p> <p>THROUGH THIS PARAMETER YOU CAN SET THE USER-ADJUSTABLE MAXIMUM HEATING TEMPERATURE.</p>	40 - 90	THE VALUE IS EXPRESSED IN °C
P21	<p>MAXIMUM DOMESTIC SETPOINT</p> <p>THROUGH THIS PARAMETER YOU CAN SET THE USER-ADJUSTABLE MAXIMUM DOMESTIC TEMPERATURE.</p>	45 - 75	THE VALUE IS EXPRESSED IN °C
P22	<p>SET POINT ΔT DELIVERY-RETURN</p> <p><i>(ONLY WITH MODULATING PUMP AND RETURN PROBE CONNECTED)</i></p> <p>THROUGH THIS PARAMETER YOU CAN SET THE TEMPERATURE DIFFERENCE BETWEEN DELIVERY AND RETURN.</p>	<p>0</p> <hr/> <p>10 - 40</p>	<p>0 = DISABLED</p> <hr/> <p>THE VALUE IS EXPRESSED IN °C</p>

2. FIRST START-UP

PARAMETER	DESCRIPTION	RANGE	FUNCTION
P23	<p>MODULATING PUMP MINIMUM SPEED (ONLY WITH MODULATING PUMP AND RETURN PROBE CONNECTED)</p> <p>THROUGH THIS PARAMETER YOU CAN SET THE MINIMUM SPEED VALUE OF THE MODULATING PUMP DURING A REQUEST TO OPERATE IN HEATING MODE.</p>	50 - 70	THE VALUE IS EXPRESSED IN PERCENTAGE
P24	<p>MODULATING PUMP MAXIMUM SPEED (ONLY WITH MODULATING PUMP AND RETURN PROBE CONNECTED)</p> <p>THROUGH THIS PARAMETER YOU CAN SET THE MAXIMUM SPEED VALUE OF THE MODULATING PUMP DURING A REQUEST TO OPERATE IN HEATING MODE.</p>	70 - 100	THE VALUE IS EXPRESSED IN PERCENTAGE
P25	<p>D.H.W STORAGE TANK TEMPERATURE SETPOINT (FOR STORAGE BOILERS ONLY)</p> <p>THROUGH THIS PARAMETER YOU CAN SET THE PRIORITY STARTING VALUE OF THE STORAGE TANK, COMPARED TO THE USER ADJUSTABLE D.H.W SETPOINT.</p>	3 - 9	THE VALUE IS EXPRESSED IN °C (PRE-SET AT 9°C)
P26	<p>MODBUS ADDRESS</p> <p>BY MEANS OF THIS PARAMETER, IT IS POSSIBLE TO SET THE ADDRESS OF THE BOARD ON MODBUS IN ORDER TO PERFORM A CASCADE SYSTEM.</p>	1 - 16	BOILER NUMBERING FOR MODBUS
P27	<p>MODBUS COMMUNICATION BAUD RATE</p> <p>BY MEANS OF THIS PARAMETER, IT IS POSSIBLE TO SELECT THE MODBUS COMMUNICATION BAUD RATE SUPPORTED BY THE SAME INTERFACE.</p>	0 - 5	0 = 9600 1 = 1200 2 = 2400 3 = 4800 4 = 9600 5 = 19200
P28	<p>MODBUS MODE</p>	0 - 2	0 = ENABLED 1 = ENABLED WITH LOCAL SETTINGS 2 = DISABLED (SET BY DEFAULT)

2. FIRST START-UP

PARAMETER	DESCRIPTION	RANGE	FUNCTION
P29	<i>ΔT HEATING POSTCIRCULATION</i> THROUGH THIS PARAMETER, IT IS POSSIBLE TO SET THE TEMPERATURE DIFFERENCE FROM THE MAIN BURNER SHUTOFF, FOR THE INTERVENTION OF THE ROOM THERMOSTAT, TO THE DISABLING OF THE PUMP IN HEATING MODE.	0 - 25	THE VALUE IS EXPRESSED IN °C (SET BY DEFAULT AT 10 °C)
P30	<i>ΔT D.H.W./TANK POSTCIRCULATION</i> THROUGH THIS PARAMETER, IT IS POSSIBLE TO SET THE TEMPERATURE DIFFERENCE FROM THE CLOSING OF THE TAP OR THE REACHING OF THE TEMPERATURE SET IN THE BOILER TO THE DISABLING OF THE PUMP IN HEATING MODE.	0 - 25	THE VALUE IS EXPRESSED IN °C (SET BY DEFAULT AT 10 °C)
P31	<i>HEATING MODE ANTI-FREEZE TEMPERATURE SETTING</i> THROUGH THIS PARAMETER, IT IS POSSIBLE TO SET THE HEATING WATER TEMPERATURE AT WHICH THE ANTI-FREEZE PROTECTION DEVICE STARTS WORKING.	5 - 12	THE VALUE IS EXPRESSED IN °C (SET BY DEFAULT AT 8 °C)
P32	<i>ENABLING FLOWMETER</i> <i>(ONLY WITH FLOWMETER KIT CODE 65-00712 CONNECTED)</i> THROUGH THIS PARAMETER IT IS POSSIBLE TO ENABLE THE FLOWMETER FOR MEASURING THE HEATING FLOW RATE AND MANAGE ACTIVATION OF THE BOILER BY THE FLOW RATE ITSELF.	0 - 2	0 = DISABLED (SET BY DEFAULT) 1 = ENABLED 2 = FLOW-SWITCH ENABLING FOR GAS HEAT PUMP (HYBRID BOILER)
P33	<i>MINIMUM THRESHOLD TO ACTIVATE THE BOILER THROUGH THE FLOWMETER</i> <i>(ONLY IF PARAMETER P32 IS SET ON THE VALUE '1' OR '2')</i> THROUGH THIS PARAMETER IT IS POSSIBLE TO SET THE MINIMUM WATER FLOW RATE REQUIRED TO ACTIVATE THE BOILER.	20 - 68	VALUE EXPRESSED IN HERTZ 20 Hz = 3.5 l/min 23 Hz = 4 l/min 28 Hz = 5 l/min 34 Hz = 6 l/min 39 Hz = 7 l/min 44 Hz = 8 l/min 50 Hz = 9 l/min 55 Hz = 10 l/min 61 Hz = 11 l/min 66 Hz = 12 l/min

2. FIRST START-UP

PARAMETER	DESCRIPTION	RANGE	FUNCTION
P34	<p>ACTIVATION OF THE AUXILIARY RELAY ON THE "SVZ" P.C.B. (SEE CHAPTER: OPTIONAL ELECTRICAL CONNECTIONS)</p> <p>THROUGH THIS PARAMETER IT IS POSSIBLE TO MANAGE THE TYPE OF FUNCTIONING OF THE AUXILIARY RELAY ON THE "SVZ" P.C.B. (CLAMP M4, PIN 5-6).</p> <p>WHEN THE VALUE OF THE PARAMETER IS SET TO '3', THE ENABLING OR DISABLING OF THE AUXILIARY RELAY IS GIVEN BY THE "TP" CONTACT (CLAMP M14, PIN 55-56, SEE CHAPTER: OPTIONAL ELECTRICAL CONNECTIONS).</p> <p>WHEN THE "TP" CONTACT IS OPEN, THE RELAY STAYS ENERGIZED (WORKING RECIRCULATION PUMP) WHILE WHEN THE "TP" CONTACT IS CLOSED, THE RELAY IS DE-ENERGIZED (NOT WORKING RECIRCULATION PUMP).</p>	0 - 4	<p>0 = DISABLED (SET BY DEFAULT)</p> <p>1 = HEATING CIRCUIT BOOSTER PUMP</p> <p>2 = D.H.W. BOOSTER PUMP</p> <p>3 = RECIRCULATION PUMP</p> <p>4 = REMOTE LED FOR SIGNALLING BOILER BLOCK (SEE CHAPTER: OPTIONAL ELECTRICAL CONNECTIONS)</p>
P35	<p>SAFETY CHECK ENABLING FOR INSUFFICIENT CIRCULATION DURING IGNITION</p> <p>BY ACTIVATING THIS PARAMETER, THE CORRECT FUNCTIONING OF THE PUMP IS CHECKED AT EACH BURNER IGNITION. THIS CHECK ALLOWS TO PROTECT THE HEAT EXCHANGER AND OTHER PARTS FROM EXCESSIVE NON-DISSIPATED HEAT, IN CASE THE PUMP DOES NOT WORK PROPERLY.</p>	0 - 1	<p>0 = DISABLED</p> <p>1 = ENABLED (SET BY DEFAULT)</p>
P36	<p>ACTIVATION AND OPERATING MODE OF THE CONTACT 'CT' THROUGH ACCESSORY COD. 40-00133 (SEE CHAPTER "OPTIONAL ELECTRICAL CONNECTIONS")</p> <p>THIS PARAMETER IS AUTOMATICALLY SET TO THE VALUE '1' WHEN THE VALUE OF PARAMETER P00 IS SET TO '11'.</p>	0 - 2	<p>0 = DISABLED (SET BY DEFAULT)</p> <p>1 = AIR PRESSURE-SWITCH SAFETY</p> <p>2 = TELEPHONE DIALER</p>

2. FIRST START-UP

2.1.6. ELECTRIC FAN FREQUENCY/HEAT CAPACITY DIAGRAM

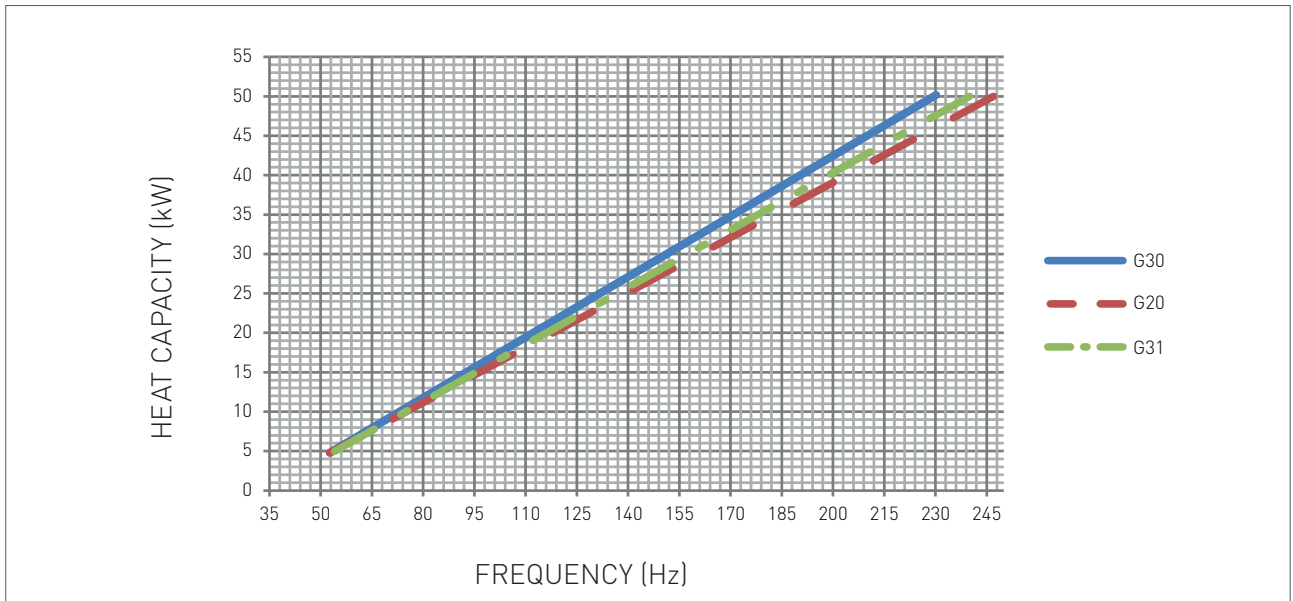

GAS TYPE		MINIMUM FREQUENCY	MAXIMUM FREQUENCY	STARTING STEP ADJUSTMENT
G20	Hz	53	247	130
G30	Hz	53	230	140
G31	Hz	53	240	140

2.2. MAINTENANCE

2.2.7. GENERAL MAINTENANCE WARNINGS



DANGER

Before each components cleaning or replacement operation, ALWAYS cut off the POWER, WATER and GAS supply of the boiler.



WARNING

To ensure greater life span and proper operation of the device, during the maintenance operations use only original spare parts.



ATTENTION

To ensure the efficiency and safety of the device, the maintenance operations must be realized on an annual basis. The operations described below, are essential to the validity of the standard Flexiheat warranty and must be performed by professionally qualified personnel in accordance with current legislation

Please perform the following operations once a year:

- › check the primary exchanger, if necessary, clean it;
- › check the operation of the gas light up and safety systems. If necessary, remove and clean the flame detection and light up electrodes from incrustations paying attention to respect the distances with respect to the burner;
- › check the sealing of the gas components, and replace if necessary the gaskets;
- › visually check the flame and the condition of the combustion chamber;
- › if necessary make sure that the combustion is suitably adjusted and if required proceed as indicated in section "CO2 VALUE CHECK AND CALIBRATION";
- › periodically check the integrity of the fume exhaustion system for safety and proper operation;
- › make sure that the permanent ventilation outlets are present, correctly sized and functioning, based on the installed devices. Respect the requirements provided by Local and National legislation;
- › check the heating circuit safety systems: limit temperature safety thermostat; limit pressure safety;
- › check the proper operation of the condensate draining system, including the devices outside the boiler such as condensate collection devices installed along the path of the fume exhaust duct or neutralization devices for acid condensate. Check that the liquid flow is not obstructed and that there are no combustion gas refluxes inside the internal system.
- › Check that the system's water PH is between 6.5 and 8.5;
- › check the pre-load pressure of the expansion vessel;
- › check the sealing of the water components, and replace if necessary the gaskets;
- › check that the wiring is performed in compliance with the requirements in the boiler instruction manual;
- › check the wiring inside the control panel;
- › remove and clean the burner from oxidation;
- › check the integrity and the position of the sealed chamber sealing gasket;

2.2.8. TECHNICAL DATA

Model	R1K 50 Rain	
CE certification	no.	0476CQ0134
Gas category		(IT) II2H3B/P
Discharge type	type	A3-B23-B23p-B33-B53
Energy efficiency 92/42 CEE	no. stars	4
Maximum nominal heat capacity in heating circuit	kW	50
Minimum nominal heat capacity in heating circuit	kW	5
Useful thermal power - 60/80°C	kW	49,19
Minimum useful thermal power - 60/80°C	kW	4,83
Useful thermal power - 30/50°C	kW	53,40
Performance at 100% Pn - 60/80°C	%	98,37
Performance at 30% Pm - return 47°C	%	102,8
Performance at 30% Pm - return 30°C	%	108,8
Performance at 100% Pn - 30/50°C	%	106,8
Maximum combustion Performance	%	97,9
Fumes temperature at nominal heat capacity	°C	66,4
Fumes temperature at minimum heat capacity	°C	56,8
CO ₂ at nominal heat capacity - G20	%	9,3 - 9,1
CO ₂ at minimum heat capacity - G20	%	9 - 8,8
CO ₂ at nominal heat capacity - G30	%	11,3 - 11,1
CO ₂ at minimum heat capacity - G30	%	10,9 - 10,7
CO ₂ at nominal heat capacity - G31	%	10,3 - 10,1
CO ₂ at minimum heat capacity - G31	%	9,9 - 9,7
CO at nominal heat capacity	ppm	68
Fumes mass at nominal heat capacity	g/s	22,19
Fumes mass at minimum heat capacity	g/s	2,28
NO _x class	class	6
Weighted Nox [0% O ₂] mg/kWh	mg/kWh	51
Heating circuit		
Adjustable heating temperature	°C	30-80 / 25-45
Maximum operating temperature for heating circuit	°C	80
Maximum operating pressure for heating circuit	bar	3
Minimum operating pressure for heating circuit	bar	0,3
Dimensional characteristics		
Width	mm	480
Depth	mm	600
Height	mm	910
Gross weight	Kg	54
Water connections		
Flow	∅	1 1/4"
Gas	∅	3/4"
Return	∅	1 1/4"
Fume exhaust fittings		
Maximum electric fan pressure available	Pa	100
Minimum electric fan pressure available	Pa	30

2. MAINTENANCE

Max discharge length Ø60 - Hor duct	m	5
Max discharge length Ø80 - Hor duct	m	25
Max discharge length Ø60 - Vert duct	m	5
Max discharge length Ø80 - Vert duct	m	25
Electrical specifications		
Voltage-frequency	V/Hz	230/50
Max Absorbed Power	W	108
Insulation rate	IP	X5D
Gas supply		
Nominal supply pressure - G20	mbar	20
Heating Max. fan speed - G20	Hz	247
Heating Min. fan speed - G20	Hz	53
Fuel consumption - G20	m ³ /h	5,29
Nominal Supply pressure - G30	mbar	30
Heating Max. fan speed - G30	Hz	230
Heating Min. fan speed - G30	Hz	53
Fuel consumption - G30	kg/h	3,94
Nominal Supply pressure - G31	mbar	37
Heating Max. fan speed - G31	Hz	240
Heating Min. fan speed - G31	Hz	53
Fuel consumption - G31	kg/h	3,88

2.2.8. TECHNICAL ASSEMBLY

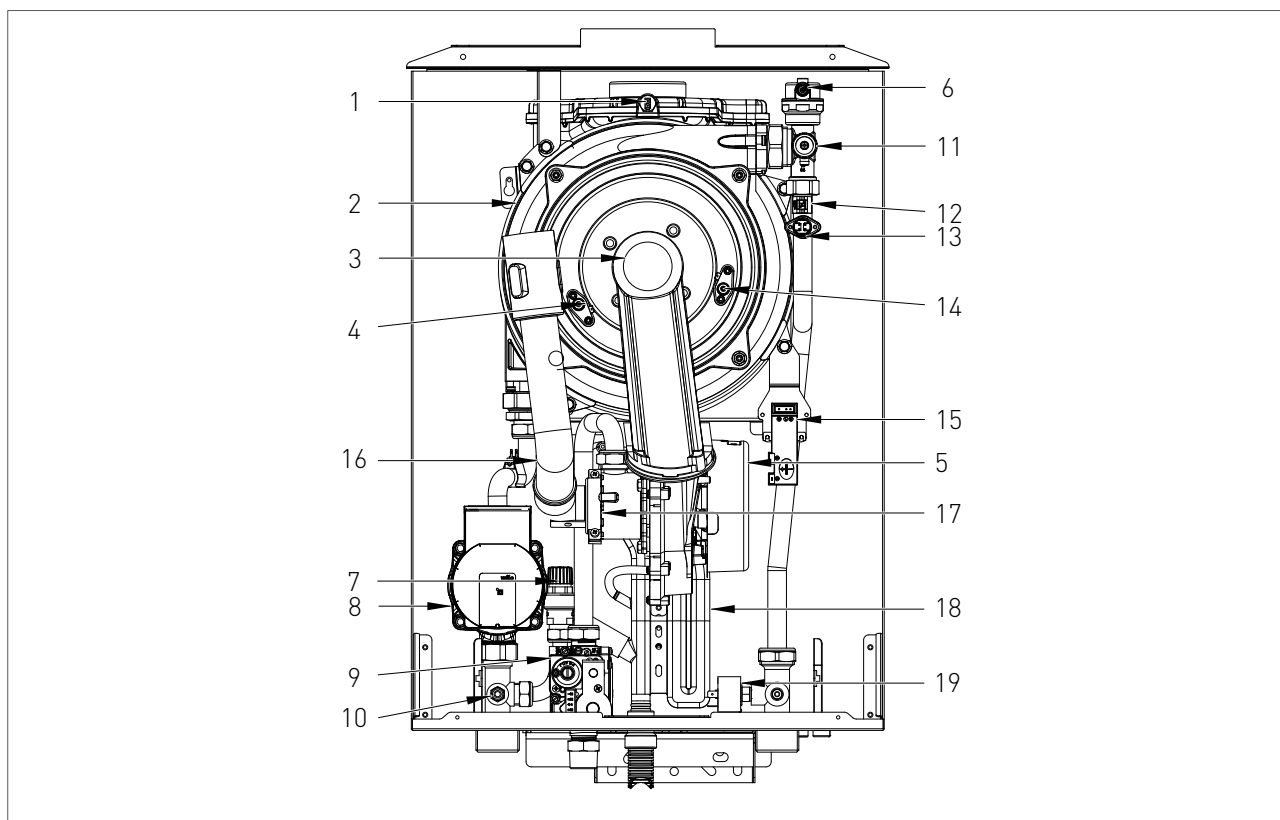

KEY

1. FUMES SAFETY THERMOFUSE
2. HEAT EXCHANGER
3. BURNER UNIT
4. DETECTION ELECTRODE
5. ELECTRIC FAN
6. AUTOMATIC AIR RELIEF VALVE
7. SAFETY VALVE 3 bar
8. CIRCULATOR
9. GAS VALVE
10. SYSTEM DRAINING TAP
11. MANUAL AIR RELIEF VALVE
12. HEATING PROBE
13. SAFETY THERMOSTAT
14. LIGHT UP ELECTRODE
15. START-UP TRANSFORMER
16. AIR SUCTION TUBE
17. PROPORTIONAL VENTURI
18. CONDENSATE COLLECTION SIPHON
19. WATER PRESSURE SWITCH

2.2.9. HYDRAULIC BOARD

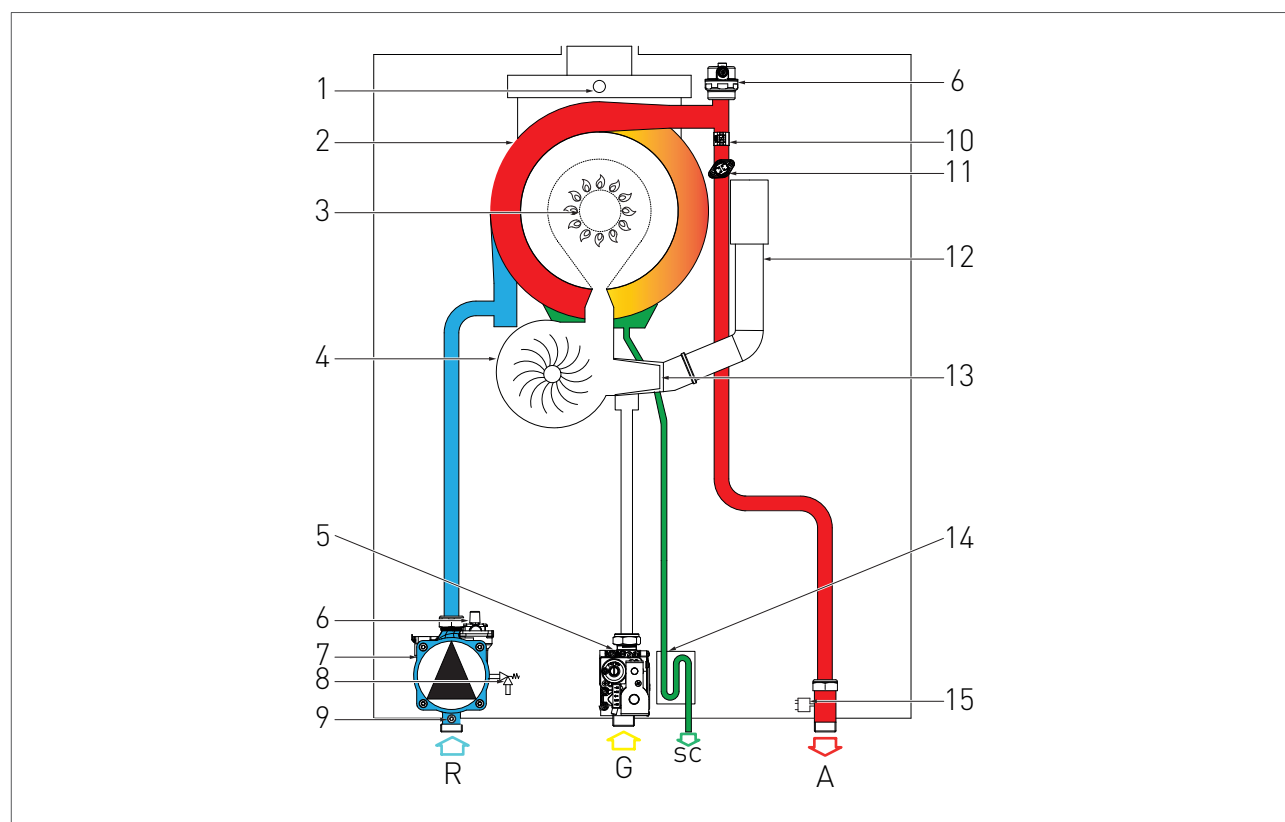
**KEY**

- R. HEATING RETURN
- G. GAS INLET
- SC. CONDENSATE DRAIN
- A. HEATING FORWARD

- 1. FUMES SAFETY THERMOFUSE
- 2. HEAT EXCHANGER
- 3. BURNER UNIT
- 4. ELECTRIC FAN
- 5. GAS VALVE
- 6. AIR RELIEF VALVE
- 7. CIRCULATOR
- 8. SAFETY VALVE 3 bar
- 9. SYSTEM DRAINING TAP
- 10. HEATING PROBE
- 11. SAFETY THERMOSTAT
- 12. AIR SUCTION TUBE
- 13. PROPORTIONAL VENTURI
- 14. CONDENSATE COLLECTION SIPHON
- 15. WATER PRESSURE SWITCH

2.2.10. WIRING DIAGRAM

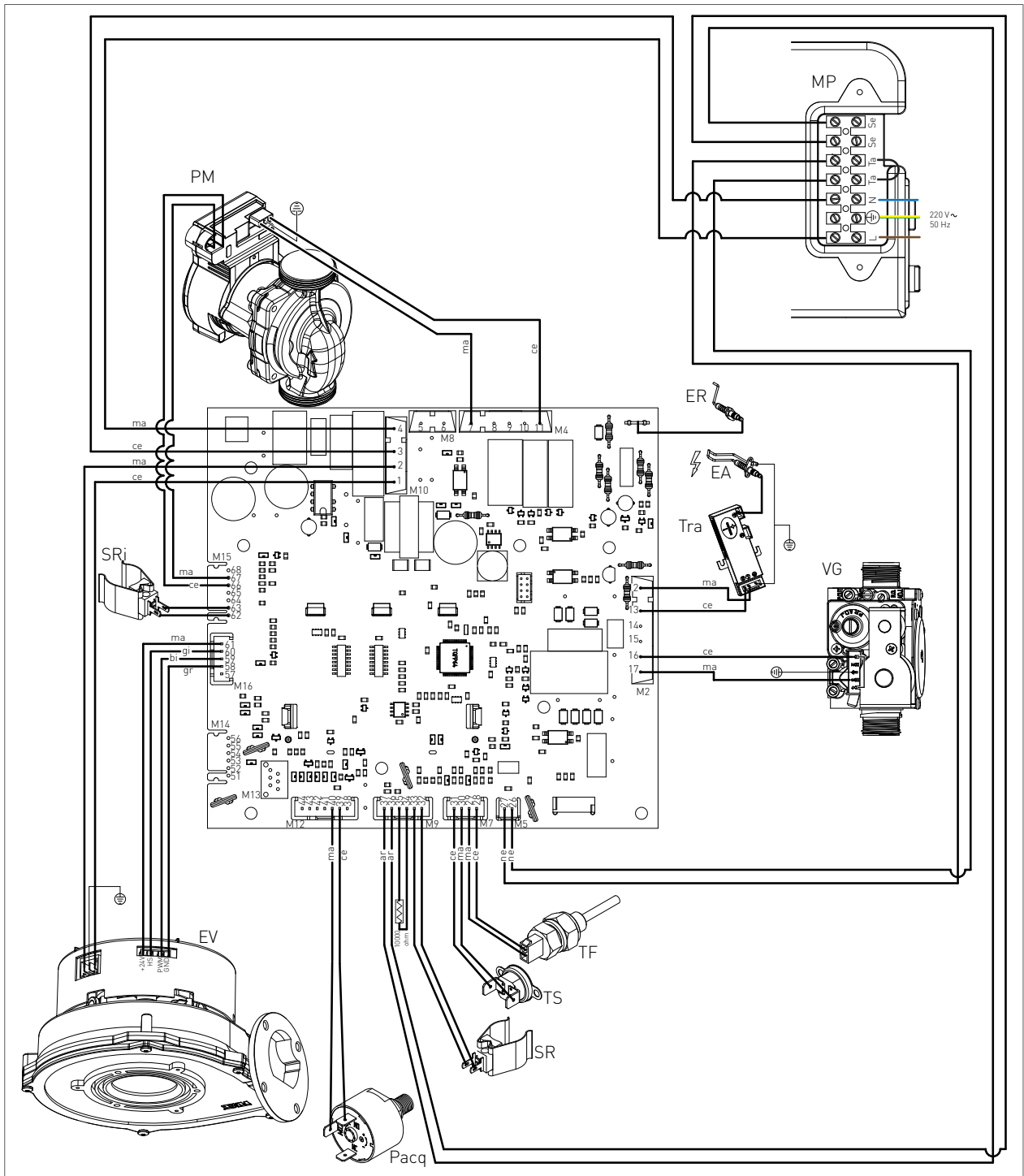

ER: DETECTION ELECTRODE	TS: SAFETY THERMOSTAT	MP: PANEL TERMINAL	CE: BLUE
EA: START-UP ELECTRODE	PACQ: WATER PRESSURE SWITCH	SE: EXTERNAL PROBE	MA: BROWN
PM: MODULATING PUMP	TF: FUMES THERMOFUSE (102°C)	TA: ENVIRONMENT THERMOSTAT	AR: ORANGE
VG: GAS VALVE	SR: HEATING PROBE	L: LINE	GI: YELLOW
TRA: START-UP TRANSFORMER	EV: ELECTRIC FAN	N: NEUTRAL	BI: WHITE
SRI: RETURN SENSOR		NE: BLACK	GR: GREY

2.2.11. ACCESSING THE BOILER

For the majority of the control and maintenance operations you have to remove one or more panels of the casing.

To intervene on the front of the boiler proceed as follows:

- > open the Locks (1-Fig. 1) with a triangle wrench;
- > pull out the front panel.

To intervene on the side panels of the boiler proceed as follows:

- > remove the fastening screws (2) placed laterally to the ABS cover and pull it out;
- > remove the fastening screws (3) placed on the bottom side of the boiler and remove the bottom cover;
- > remove the fastening screws (4) placed in the front edge of the side panel;
- > grasp the base of the panel and, after moving it sideways, pull it down.

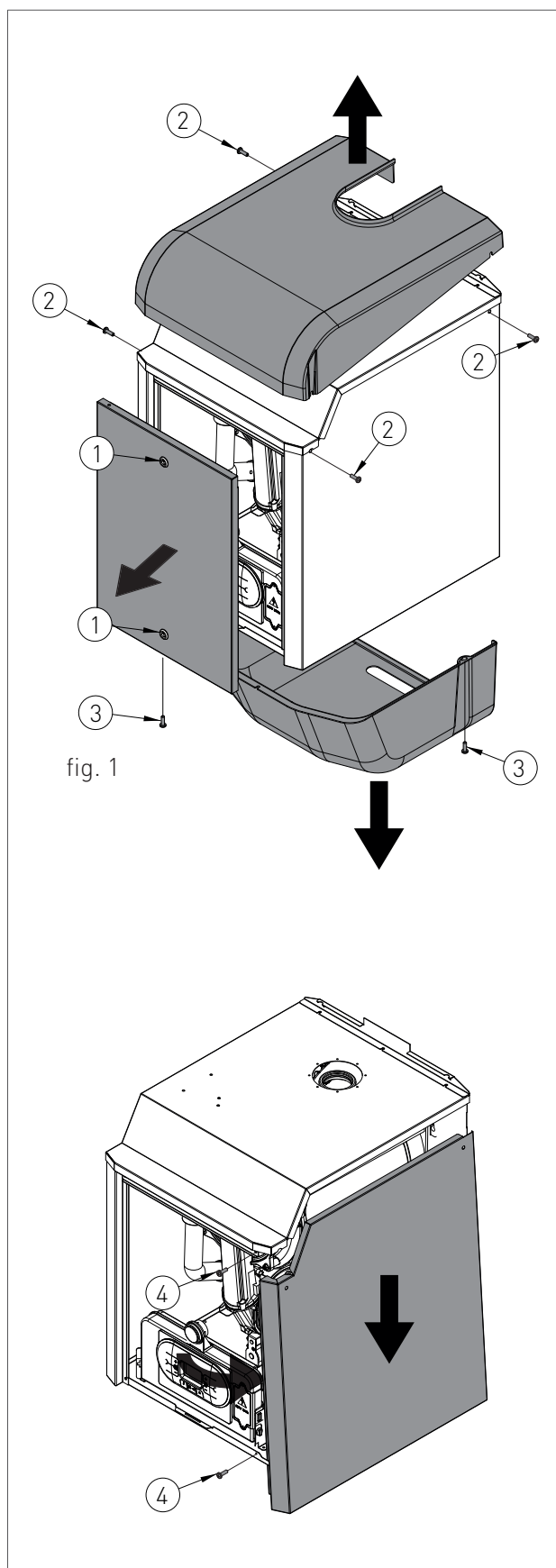

2.2.12. ACCESSING THE ELECTRONIC BOARD

In order to intervene on the wirings of the control panel, please proceed as follows:



DANGER

Cut off the voltage from the main switch.

- › Grab at the same time the support brackets of the control panel (fig. 1) loosening them and turn the panel downwards;
- › unscrew the four fastening screws 1 - fig. 1;
- › remove the crankcase pulling it upwards.

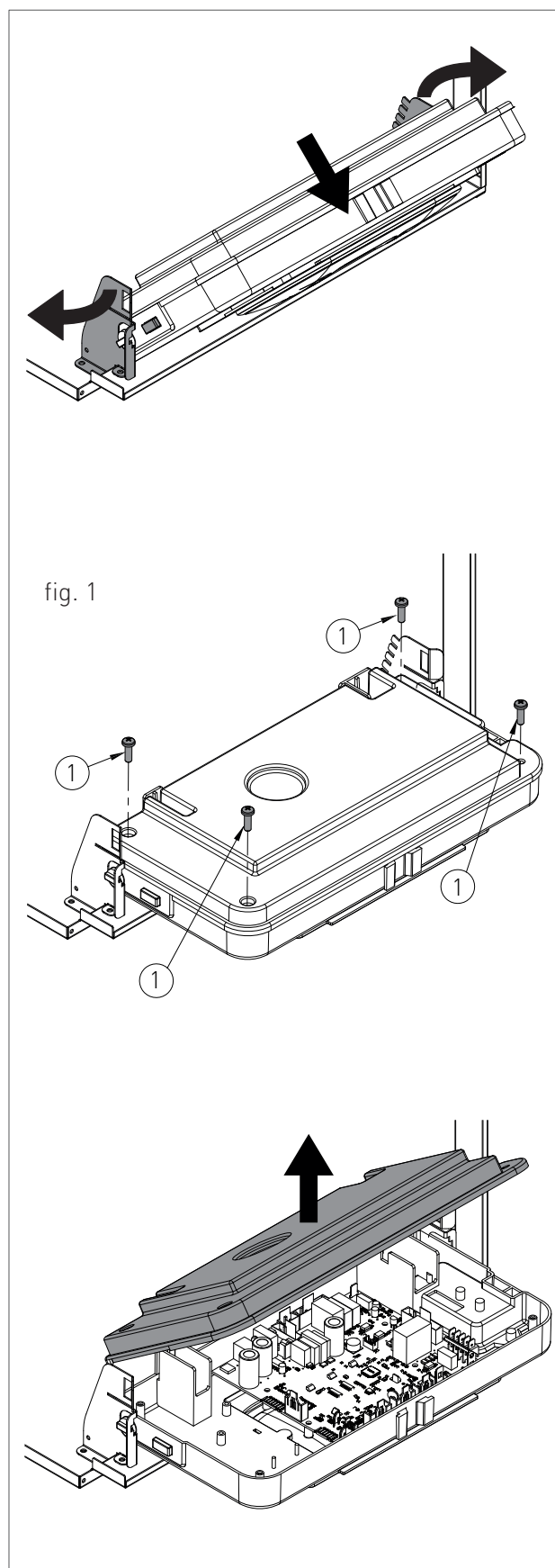

2.2.13. SYSTEM EMPTYING

HEATING SYSTEM EMPTYING

Whenever you need to empty the system, proceed as follows:

- › switch the boiler to “WINTER” mode and activate it;
- › turn off the main power supply switch;
- › wait for the boiler to cool down;
- › connect a flexible tube to the system emptying outlet and connect the other end of the tube to a suitable discharge;
- › turn the discharge tap of the system 'RS' (fig. 1);
- › open the relief valves of the radiators starting from the one at the top and continuing downwards;
- › after draining out all water, close the relief valves of the radiators and the emptying tap.

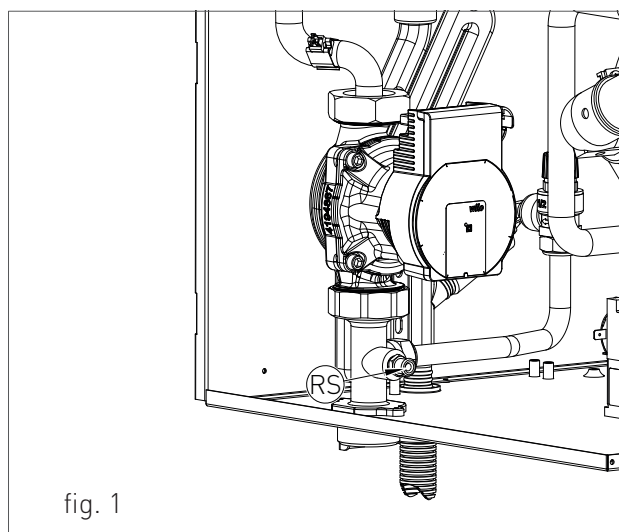



fig. 1

2.2.14. FAULT SIGNALLING CODES

To view the last 5 fault signalling codes chronologically, starting with the most recent one, activate the 'OFF' mode by pressing the FUNCTION **MON** key and hold the key INFO **i** for 5 seconds. Use keys **+** and **-** of the heating circuit **III** to scroll through the list of saved faults. To reset the fault history press the RESET **R** key. To exit display mode press the INFO **i** key.

CODE	FAULT	POSSIBLE CAUSE	SOLUTION	RESET
E01	FLAME BLOCK	NO FLAME LIGHT UP		MANUAL RESET (PRESS THE RESET R KEY).
		GAS MISSING;	CHECK THE ADDUCTION NETWORK;	
		MASS OR BROKEN START-UP ELECTRODE;	REPLACE IT;	
		GAS VALVE BROKEN;	REPLACE IT;	
		SLOW LIGHT UP TOO LOW ADJUSTMENT;	ADJUST MINIMUM OR SLOW LIGHT UP;	
		VALVE INFEED PRESSURE TOO HIGH (ONLY FOR GPL BOILERS).	CHECK THE MAXIMUM ADJUSTMENT PRESSURE	
		WITH FLAME LIGHT UP		
		NEUTRAL AND PHASE INVERTED POWER SUPPLY;	PROPERLY CONNECT THE POWER SUPPLY;	
		DETECTION ELECTRODE BROKEN;	REPLACE IT;	
		DETECTION ELECTRODE CABLE DISCONNECTED.	CHECK THE WIRING.	
ELECTRICAL CURRENT PHASE-PHASE	IF THE TENSION MEASURES BETWEEN NEUTRAL AND GROUND IS ALMOST EQUAL TO THE ONE MEASURED BETWEEN PHASE AND GROUND, YOU HAVE TO INSTALL A PHASE-PHASE TRANSFORMER KIT (COD. 88021LA)			

2. MAINTENANCE

CODE	FAULT	POSSIBLE CAUSE	SOLUTION	RESET
E02	SAFETY THERMOSTAT <i>(95°C)</i>	THERMOSTAT CABLE DISCONNECTED;	CHECK THE WIRING;	AUTOMATIC.
		BROKEN THERMOSTAT.	REPLACE IT.	
E03	FUMES SAFETY THERMOFUSE <i>(102°C)</i>	THERMOFUSE BROKEN;	REPLACE IT;	MANUAL RESET (PRESS THE RESET  KEY).
		THERMOFUSE CABLE DISCONNECTED.	CHECK THE WIRING.	
E04	WATER MISSING IN THE SYSTEM	INSUFFICIENT WATER PRESSURE INSIDE THE SYSTEM (LOWER THAN 0.3 BAR);	LOAD THE SYSTEM;	AUTOMATIC.
		WATER PRESSURE SWITCH CABLE DISCONNECTED;	CHECK THE WIRING;	
		WATER PRESSURE SWITCH BROKEN.	REPLACE IT.	
E05	HEATING PROBE	BROKEN OR INCORRECTLY CALIBRATED PROBE (RESISTANCE VALUE 10 KOHM AT 25 °C NTC);	REPLACE IT;	AUTOMATIC.
		DISCONNECTED OR WET PROBE CONNECTOR.	CHECK THE WIRING.	
E10	LOW FLOW RATE	THE FLOW RATE VALUE DETECTED BY THE FLOWMETER IS LOWER THAN THE VALUE SET AT PARAMETER P33.	INCREASE THE FLOW RATE OR LOWER THE VALUE AT PARAMETER P33.	AUTOMATIC.
E14	AIR PRESSURE SWITCH	AIR PRESSURE SWITCH CABLE DISCONNECTED;	CHECK THE WIRING;	MANUAL RESET (PRESS THE RESET  KEY).
		DISCHARGE OR SUCTION CLOSED;	CHECK THE FUMES DISCHARGE DUCT;	
		AIR PRESSURE SWITCH DEFECTIVE.	REPLACE IT.	

2. MAINTENANCE

CODE	FAULT	POSSIBLE CAUSE	SOLUTION	RESET
E15	RETURN PROBE	BROKEN OR INCORRECTLY CALIBRATED PROBE (RESISTANCE VALUE 10 KOHM AT 25 °C NTC);	REPLACE IT;	AUTOMATIC.
		DISCONNECTED OR WET PROBE CONNECTOR.	CHECK THE WIRING.	
E16	ELECTRIC FAN	ELECTRIC FAN BOARD BROKEN;	REPLACE IT;	AUTOMATIC.
		ELECTRIC FAN BROKEN;	REPLACE IT;	
		FAULTY POWER SUPPLY CABLE.	REPLACE IT.	
E18	INSUFFICIENT CIRCULATION	EXCHANGER OBSTRUCTED;	CLEAN OR REPLACE THE EXCHANGER;	AUTOMATIC.
		CIRCULATOR BROKEN OR DIRTY IMPELLER.	CLEAN THE IMPELLER OR REPLACE THE CIRCULATOR.	
E21	GENERAL INTERNAL BOARD ERROR	INCORRECT SIGNAL RECOGNITION BY THE MODULATION BOARD MICRO-PROCESSOR.	IF THE MODULATION BOARD DOES NOT RESET THE ERROR AUTOMATICALLY, REPLACE IT.	AUTOMATIC.
E22	PARAMETERS PROGRAMMING REQUEST	MICRO=PROCESSOR MEMORY LOSS.	PARAMETERS REPROGRAMMING.	MANUAL RESET (CUT OFF THE TENSION).
E31	INCOMPATIBLE REMOTE CONTROL	FUNCTION ACTIVE WHEN THE CONNECTED REMOTE CONTROL IS NOT COMPATIBLE WITH THE P.C.B.	REPLACE IT WITH A COMPATIBLE ONE.	AUTOMATIC.
E32	COMMUNICATION ERROR BETWEEN THE BOILER BOARD AND THE MODBUS BOARD	NO ELECTRICAL CONNECTION;	CHECK THE WIRING;	AUTOMATIC.
		MODBUS BOARD BROKEN;	REPLACE IT;	

2. MAINTENANCE

CODE	FAULT	POSSIBLE CAUSE	SOLUTION	RESET
E35	RESIDUAL FLAME	FAULTY DETECTION ELECTRODE;	CLEAN IT OR REPLACE IT;	MANUAL RESET (PRESS THE RESET  KEY).
		FAULTY DETECTION ELECTRODE CABLE;	REPLACE IT;	
		FAULTY MODULATION BOARD.	REPLACE IT.	
E40	SUPPLY VOLTAGE	SUPPLY VOLTAGE OFF THE OPERATION RANGE (≤ 160 VOLTS).	CHECK THE POWER SUPPLY NETWORK (THE ERROR DEACTIVATES AUTOMATICALLY AS SOON AS THE SUPPLY VOLTAGE FALLS BACK WITHIN THE REQUESTED LIMITS).	AUTOMATIC.
E52	COMMUNICATION FAULT BETWEEN MODBUS CONTROLLER AND MODBUS CONTROL UNIT	NO ELECTRICAL CONNECTION;	CHECK THE WIRING;	AUTOMATIC.
		MODBUS CONTROL UNIT BROKEN.	REPLACE IT;	

2. MAINTENANCE

2.2.15. ACTIVE FUNCTIONS SIGNALLING CODES

CODE	FUNCTION	DESCRIPTION
F07	CHIMNEY SWEEP ACTIVE	YOU CAN ACTIVATE IT BY HOLDING FOR 7 SECONDS THE RESET  KEY AND YOU CAN DEACTIVATE IT BY TURNING OFF THE BOILER. THIS FUNCTION BRINGS THE BOILER TO ITS MINIMUM AND MAXIMUM HEATING POWER FOR 15 MINUTES DEACTIVATING THE MODULATION FUNCTION. GENERALLY USED FOR PERFORMING THE COMBUSTION AND CALIBRATION TESTS.
F08	HEATING CIRCUIT ANTI-FREEZE	IT ACTIVATES AUTOMATICALLY WHEN THE HEATING PROBE DETECTS A TEMPERATURE OF 12°C. THE BOILER OPERATES AT MINIMUM GAS PRESSURE WITH THE DIVERTER VALVE SET TO 'WINTER' MODE. IT DEACTIVATES WHEN THE HEATING FLOW WATER TEMPERATURE REACHES THE 30°C AND, IN PRESENCE OF A RETURN SENSOR, WHEN THE HEATING RETURN WATER TEMPERATURE REACHES THE 20°C.
F33	SYSTEM AIR RELEASE CYCLE	IT ACTIVATES AUTOMATICALLY AT FIRST BOILER START-UP, PERFORMING FOR 5 MINUTES A SERIES OF CYCLES DURING WHICH THE PUMP IS ACTIVATED FOR 40 SECONDS AND DEACTIVATED FOR 20 SECONDS. REGULAR OPERATION IS ALLOWED ONLY AFTER THIS FUNCTION IS COMPLETED. IT CAN ALSO ACTIVATE DURING NORMAL BOILER OPERATION, IF THE WATER PRESSURE SWITCH CONFIRMATION IS MISSING, WHEN THE CONTACT IS RE-CLOSED, A 2 MINUTES RELEASE CYCLE WILL BE PERFORMED.

2.2.16. GAS CONVERSION

**ATTENTION**

Make sure that the gas adduction tube is suitable for the new type of fuel with which the boiler is supplied.

- › loosen the two screws '1' (fig.1) from the fastening bush, and remove the air suction tube;
- › unscrew the tube coupling that connects the gas valve to venturi;
- › unscrew the three fastening screws '2' (fig.1) of the venturi 'V' (fig.1) using a 10 key, as shown in figure 2;
- › remove the two screws '3' (fig.3) and apply pressure on the rear side of venturi 'C' (fig.3);
- › replace the body venturi with the one suitable for the type of supply gas (cod. 30-00225 for Natural gas / cod. 30-00226 for Universal LPG) and make sure the tooth 'D' (fig.3) is adjusted downwards on the aluminium ring nut (see fig.3);
- › remount the components following the demounting operations in reverse making sure that gasket 'G' is re-assembled as shown in fig.1;
- › set the boiler to operate with the new type of gas, changing the value of the parameter P02 'GAS TYPE SELECTION' from the control panel (see chapters 'DIGITECH CS PARAMETERS TABLE' and 'ACCESSING AND PROGRAMMING THE PARAMETERS');
- › adjust the CO₂ combustion value as indicated in chapter 'CO₂ VALUE CHECK AND CALIBRATION'.

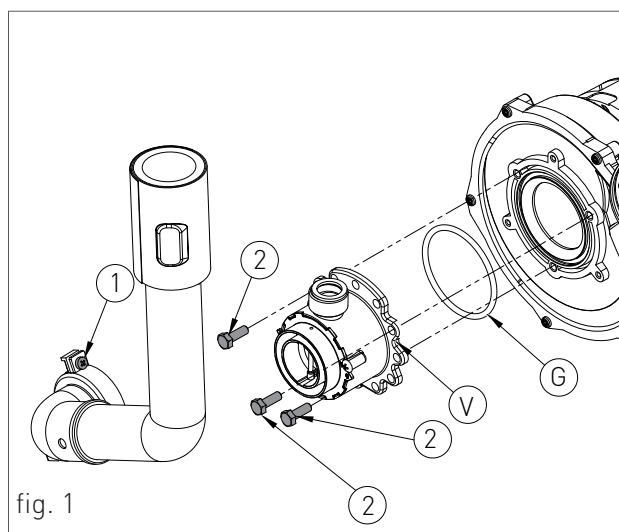

fig. 1

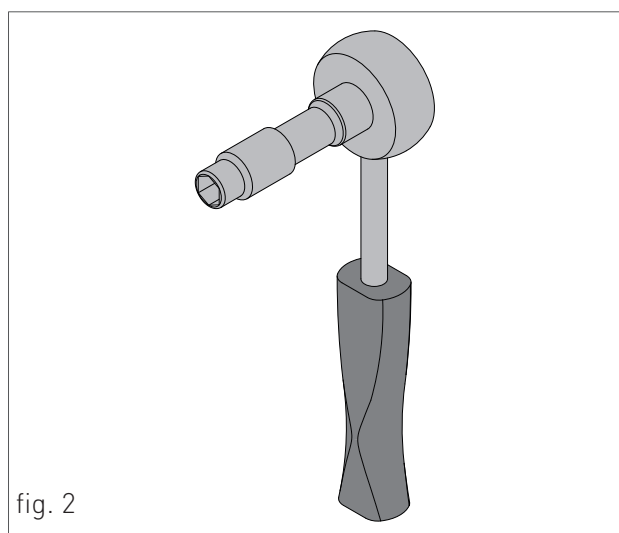

fig. 2

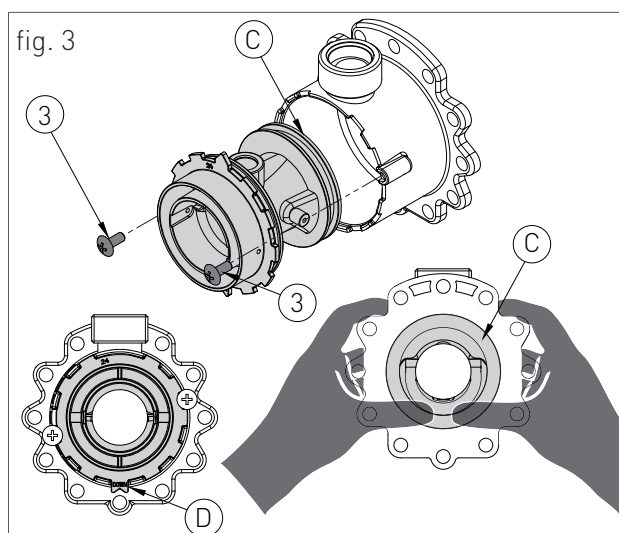

fig. 3

3. USER SECTION

The operations described in this section are addressed to all those who will use the machine. The machine must be used and accessed only by qualified operators that fully read and understood the User section, paying particular attention to the warnings.

3.1. USE

3.1.1. GENERAL USE WARNINGS

**WARNING**

Before starting the boiler the User must make sure that the First start-up certificate has the stamp of the technical Support Centre proving the testing and the first start-up of the boiler.

**WARNING**

In order to take advantage of the guarantee provided by the manufacturer, the customer should carefully and exclusively observe the instructions given in the USER section of the manual.

**ATTENTION**

This machine may be used only for the purpose for which it has been designed: heat water to a temperature below boiling point at atmospheric pressure. Any other use is considered wrong and dangerous. The manufacturer is excluded from any contractual or out of contract responsibility for damage caused to people, animals or property due to incorrect use.

**DANGER**

The boiler should not be used by persons (including children) with reduced physical, sensory or mental capacities or without suitable knowledge or experience unless they are instructed on the device use or monitored by a person responsible for their safety.

**DANGER**

DO NOT obstruct the air vents of the location in which the gas device is installed to prevent the formation of toxic explosive mixes.

**DANGER**

If you sense a gas odour in the location in which the boiler is installed, proceed as follows:

- › DO NOT use electrical switches, the telephone or any other device that might generate electrical discharges or sparks;
- › Immediately open all doors and windows to create an air exchange that can quickly clean the location;
- › Close the gas valves;
- › Request immediate intervention of qualified staff.

**DANGER**

The use of the electrical power boiler implies respecting some fundamental rules such as:

- › DO NOT touch the device with wet and/or humid parts and/or with bare feet;
- › DO NOT pull the electrical cables;
- › DO NOT leave the device exposed to atmospheric agents (rain, sun, etc.) unless specifically intended;
- › in case of cable damage, turn off the device and contact qualified professional staff to replace it.

3.1.2. CONTROL PANEL

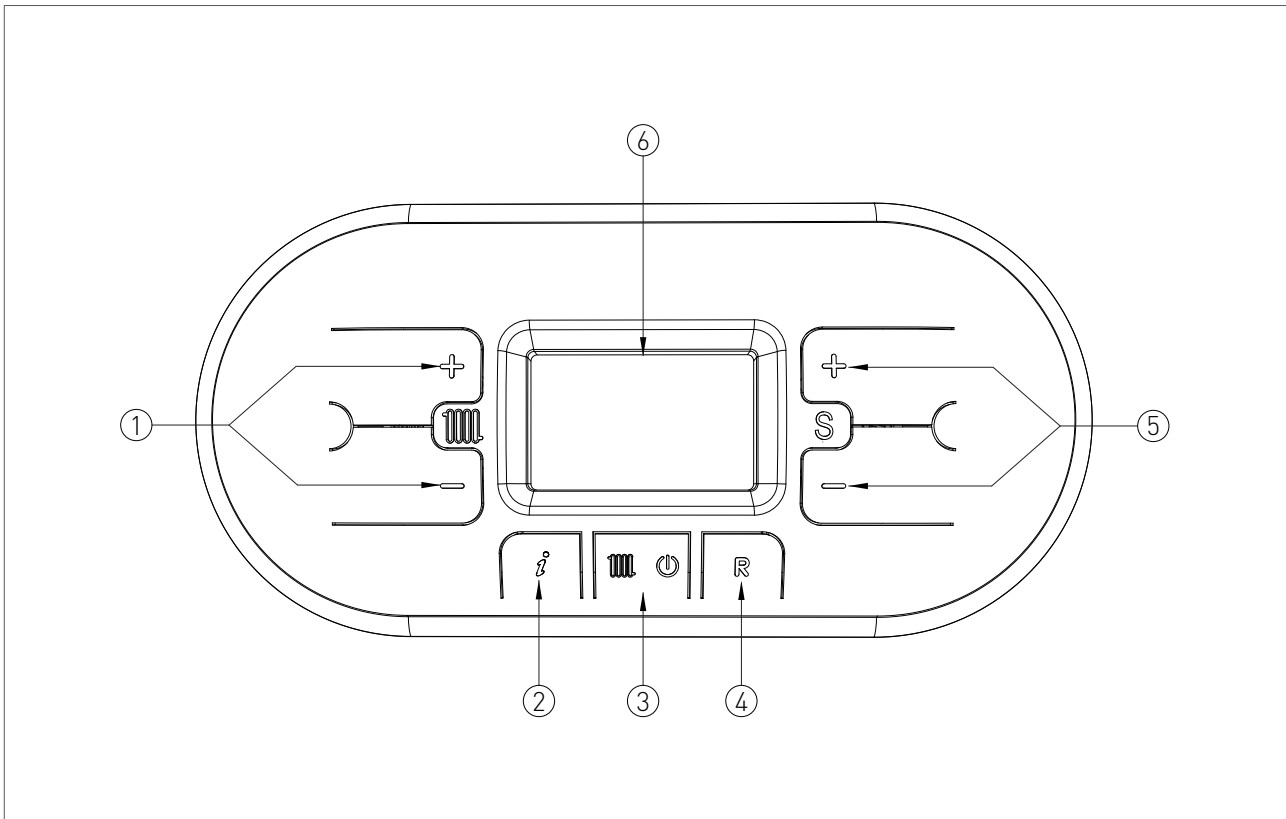





KEY







6. DISPLAY

1. HEATING TEMPERATURE ADJUSTMENT KEYS
2. INFO KEY: PRESS ONCE TO VIEW THE TEMPERATURES AND OTHER INFORMATION (see chapter 'INFO MENU DISPLAY') - HOLD FOR 5 SECONDS, IN OFF OPERATING MODE, TO VIEW THE LAST 5 FAULTS
3. OPERATING MODE SELECTION KEY: ONLY HEATING / OFF
4. RESET KEY: FAULTS RESET - CHIMNEY SWEEP FUNCTION ACTIVATION (HOLD FOR 7 SECONDS)
5. VALUE OF THE PARAMETERS ADJUSTMENT KEY / HOLD THE KEYS AT THE SAME TIME FOR 5 SECONDS TO ACTIVATE DISPLAY BACK LIGHT FOR 10 MINUTES

3.1.4. INFO MENU DISPLAY DATA

To view the boiler data from info menu you just have to press the INFO  key. The info code will be displayed on the left side of the screen and its relative value will be displayed on the centre of the screen. Use keys  and  of the heating circuit  to scroll through the list of displayed data. To exit display mode press the INFO  key.

LIST OF DISPLAYED DATA

INFO CODE	ICON	DESCRIPTION
d0		DOMESTIC CIRCUIT PROBE TEMPERATURE
d1		EXTERNAL PROBE TEMPERATURE
d2		FAN SPEED
d3		BOTTOM AREA PROBE TEMPERATURE [IF AREA BOARD INSTALLED]
d4		RETURN PROBE TEMPERATURE
d5		SOLAR COLLECTOR TEMPERATURE [IF SOLAR BOARD INSTALLED] (SCS)
d6		SOLAR BOILER TEMPERATURE (BOTTOM) [IF SOLAR BOARD INSTALLED] (SBS1)
d7		SOLAR BOILER TEMPERATURE (TOP) [IF SOLAR BOARD INSTALLED] (SBS2)
d8		SOLAR COLLECTOR PROBE TEMPERATURE 2 [IF SOLAR BOARD INSTALLED] (SCS2)
d9		EXTRA SOLAR BOILER TEMPERATURE [IF SOLAR BOARD INSTALLED] (SBS3)
dA		INERTIAL STORAGE SENSOR TEMPERATURE
dB		LOW-TEMPERATURE HEATING CIRCUIT RETURN SENSOR TEMPERATURE (IN HYBRID SYSTEM BOX MODE) - HEATING PUMP RETURN SENSOR TEMPERATURE (IN HYBRID DOMESTIC SYSTEM MODE)
dC		HYBRID SYSTEM BOX D.H.W. TANK SENSOR TEMPERATURE - HOT WATER TEMPERATURE OUT OF THE REMOTE TANK TO THE BOILER (ONLY FOR HYBRID DOMESTIC SYSTEM WITH OPTIONAL SENSOR)
dD		POWER SUPPLIED BY THE HEATING PUMP IN KW/H (ONLY FOR HYBRID DOMESTIC SYSTEM)
dE		HEATING FLOW RATE DISPLAY EXPRESSED IN L/MIN (IF THERE IS A FLOWMETER).

3.1.5. START-UP



Before starting the boiler make sure that it is powered and that the gas tap below the boiler is open.

To start the boiler press the function key  and select the desired operating mode. If the symbol is displayed fixed, it means that the function was activated.

3.1.6. OPERATING MODE



ONLY HEATING MODE



In this mode the boiler meets only the demands of heating.

To switch the boiler to ONLY HEATING operating mode, press the function key , the symbol  will appear fixed on the display, indicating that the function is enabled.

Whenever heating energy is needed to heat the rooms the automatic start-up system will start the burner; this is indicated by displaying the symbol  blinking.

ADJUSTING THE HEATING TEMPERATURE



You can adjust the temperature using keys  and  of the heating circuit .

- press key  to decrease the temperature.
- press key  to increase the temperature.

The heating temperature adjustment field ranges from 30 °C to 80 °C [25 °C – 45 °C for floor systems].

OFF MODE

In this mode the boiler no longer meets the heating demands, the anti-freeze and pump anti-locking systems still remain active.

To switch the boiler to OFF operating mode, press the function key , the symbol  will appear fixed on the display, indicating that the function is enabled (for non condensing models will appear the message 'OFF').

If the boiler was previously running, it will be turned off and the post-ventilation and post-circulation functions will be enabled.

If you have to deactivate the boiler for a long period of time, proceed as follows:

- › contact the Technical support centre that will empty the water system, where no anti-freeze is intended, and will cut off the power, water and gas supply.
- › Or leave the boiler in OFF operating mode keeping active the electrical and gas supplies so that the anti-freeze function may activate.

3.1.7. INFORMATIONAL NOTE ON ANTI-FREEZE FUNCTION

The boiler is protected against freezing thanks to the electronic board preparation with functions that start the burner and heat the concerned parts when their temperature goes below the minimum pre-set values.





WARNING

This function is available only if:

- › the boiler is powered;
- › the gas supply is open;
- › the pressure of the system is proper;
- › the boiler is not blocked.

3.1.8. FAULT SIGNALLING CODES

The boiler might signal some faults by displaying a code. Below you have a list of the codes and of the operations to be performed in order to unlock the boiler.

CODE	ICON	FAULT	INTERVENTION
E01	RESET	FLAME BLOCK	<p>MAKE SURE THAT THE BOILER AND CONTACTOR GAS VALVES ARE OPEN.</p> <hr/> <p>PRESS THE RESET  BUTTON ON THE CONTROL PANEL TO RESET THE FAULT, AS SOON AS THE ERROR CODE DISAPPEARS FROM THE DISPLAY, THE BOILER WILL START AUTOMATICALLY.</p> <hr/> <p>IF THE BLOCK PERSISTS CONTACT THE TECHNICAL SUPPORT CENTRE.</p>
E02	RESET	SAFETY THERMOSTAT (95 °C)	CONTACT THE TECHNICAL SUPPORT CENTRE.
E03	RESET	FUMES SAFETY THERMOFUSE (102 °C)	CONTACT THE TECHNICAL SUPPORT CENTRE.
E04		WATER MISSING IN THE SYSTEM	<p>IF THE SYSTEM PRESSURE IS BELOW 1.2 BAR, FILL THE SYSTEM AS DESCRIBED IN CHAPTER "SYSTEM FILLING".</p> <hr/> <p>IF THE BLOCK PERSISTS CONTACT THE TECHNICAL SUPPORT CENTRE.</p>
E05	SERVICE	HEATING PROBE	CONTACT THE TECHNICAL SUPPORT CENTRE.
E10	SERVICE	LOW FLOW RATE	CONTACT THE TECHNICAL SUPPORT CENTRE.
E14	SERVICE	AIR PRESSURE SWITCH	CONTACT THE TECHNICAL SUPPORT CENTRE.
E15	SERVICE	RETURN PROBE	CONTACT THE TECHNICAL SUPPORT CENTRE.
E16	SERVICE	ELECTRIC FAN	CONTACT THE TECHNICAL SUPPORT CENTRE.
E18	SERVICE	INSUFFICIENT CIRCULATION	CONTACT THE TECHNICAL SUPPORT CENTRE.
E21	SERVICE	GENERAL INTERNAL BOARD ERROR	<p>CUT OFF THE POWER SUPPLY FROM THE MAIN SWITCH AND THEN RESTORE IT, AS SOON AS THE ERROR CODE DISAPPEARS, THE BOILER WILL RESTART AUTOMATICALLY.</p> <hr/> <p>IF THE BLOCK PERSISTS CONTACT THE TECHNICAL SUPPORT CENTRE.</p>

3. USE

CODE	ICON	FAULT	INTERVENTION
E22	SERVICE	PARAMETERS REQUEST	PROGRAMMING CUT OFF THE POWER SUPPLY FROM THE MAIN SWITCH AND THEN RESTORE IT, AS SOON AS THE ERROR CODE DISAPPEARS, THE BOILER WILL RESTART AUTOMATICALLY. IF THE BLOCK PERSISTS CONTACT THE TECHNICAL SUPPORT CENTRE.
E31	SERVICE	INCOMPATIBLE REMOTE CONTROL	CONTACT THE TECHNICAL SUPPORT CENTRE.
E32	SERVICE	COMMUNICATION ERROR BETWEEN THE BOILER BOARD AND THE MODBUS BOARD	CONTACT THE TECHNICAL SUPPORT CENTRE.
E35	RESET	RESIDUAL FLAME	PRESS THE RESET  BUTTON ON THE CONTROL PANEL TO RESET THE FAULT, AS SOON AS THE ERROR CODE DISAPPEARS FROM THE DISPLAY, THE BOILER WILL START AUTOMATICALLY.
E40	SERVICE	SUPPLY VOLTAGE	CONTACT THE TECHNICAL SUPPORT CENTRE.
E52	SERVICE	COMMUNICATION FAULT BETWEEN MODBUS CONTROLLER AND MODBUS CONTROL UNIT	CONTACT THE TECHNICAL SUPPORT CENTRE.

3.1.9. ACTIVE FUNCTIONS SIGNALLING CODES

CODE	FUNCTION	INTERVENTION
F08	H E A T I N G A N T I - F R E E Z E F U N C T I O N A C T I V E	WAIT UNTIL THE OPERATION IS COMPLETED
F33	S Y S T E M A I R R E L E A S E C Y C L E I N P R O G R E S S	WAIT UNTIL THE OPERATION IS COMPLETED

3.1.10. COVER CLEANING

Clean the cover of the device using a wet cloth and come neutral soap.



WARNING

DO NOT use abrasive or powder detergents as they might damage the plastic cover and control elements.

3.1.11. DISPOSAL

The device and all its accessories must be differentiated, suitably disposed of in accordance with the standards in force.



The use of the symbol WEEE (Waste Electrical and Electronic Equipment) shows that this product cannot be dismantled as domestic waste. Proper dismantle of this product helps preventing potentially negative consequences on human health and environment.



FLEXIHEAT UK LTD

www.flexiheatuk.com

01202 822221