



**FLEXIHEAT UK LTD**

[www.flexiheatuk.com](http://www.flexiheatuk.com)

01202 82221



**LEO D S / LEO D S BMS / LEO DT S**  
**LEO D L / LEO D L BMS / LEO DT L**  
**LEO D XL / LEO D XL BMS / LEO DT XL**

---

**DESTRATIFICATOR**

TECHNICAL DOCUMENTATION OPERATION MANUAL

## TABLE OF CONTENTS

1. Purpose and Principle of Operation.....	2
2. Technical Data.....	3
3. Wiring diagrams.....	4
4. Installation.....	5
4.1. Montage distance.....	5
4.2. Method of installation.....	5
5. Start-up and operation.....	6
6. Service and warranty terms.....	7
7. Conformity with WEEE directive 2012/19/UE.....	9

## 1. PURPOSE AND PRINCIPLE OF OPERATION

Destratificator (under ceiling air mixer) co-operates with various devices of the heating system and is used for improving the efficiency of heating in high objects such as: industrial shops, storehouses, supermarkets, exhibition halls.

The primary function of the under ceiling air mixer is counteracting the accumulation of warm air in upper zones of the room. An axial fan draws warm air in and forces its flow downwards, i.e. towards the zone occupied by people (the thermal comfort zone). This results in a reduction of heat losses through the ceiling and causes a faster heating of the building.

Destratificator is designed for installation indoors, in an environment protected against weather conditions and in rooms in which there is no risk of explosion.

## 2. TECHNICAL DATA

### LEO D S | LEO D S BMS | LEO DT S

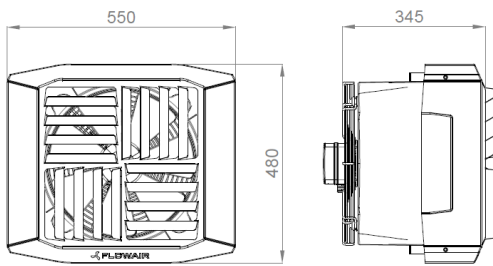

### LEO D L | LEO D L BMS | LEO DT L

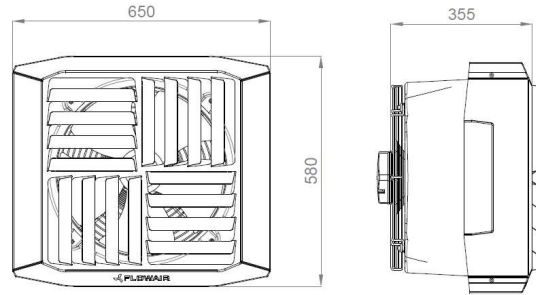

### LEO D XL | LEO D XL BMS | LEO DT XL

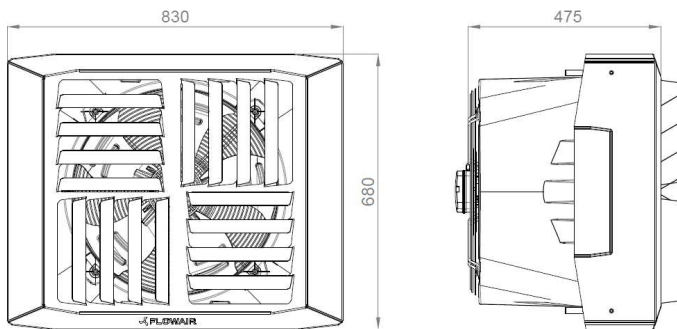

EN	LEO D S			LEO D L			LEO D XL		
	III	II	I	III	II	I	III	II	I
Gear									
Air flow [m <sup>3</sup> /h]	2500	2200	1900	5200	4200	2800	7200	6100	3900
Max. current consumption [A]	0,5	0,4	0,3	1,3	1,0	0,6	2,0	1,5	1,3
Maximum power consumption [W]	110	80	70	280	200	120	450	350	260
Electric power supply	230V / 50Hz								
Acoustic pressure level* [dB(A)]	56,9	55,2	49,4	65,7	58,4	44,9	72,8	66,9	53,7
Motor protection degree	IP 54								
Motor insulation class	F								
Weight [kg]	8,9			13,9			19,5		

\*Acoustic pressure level measured in the room of average sound absorption, capacity 1500m<sup>3</sup>, at distance of 5m from the unit.

### 3. WIRING DIAGRAMS

#### LEO D / LEO DT

Hi / N / Pe - 3rd fan speed  
 Med. / N / Pe - 2nd fan speed  
 Low / N / Pe - 1st fan speed

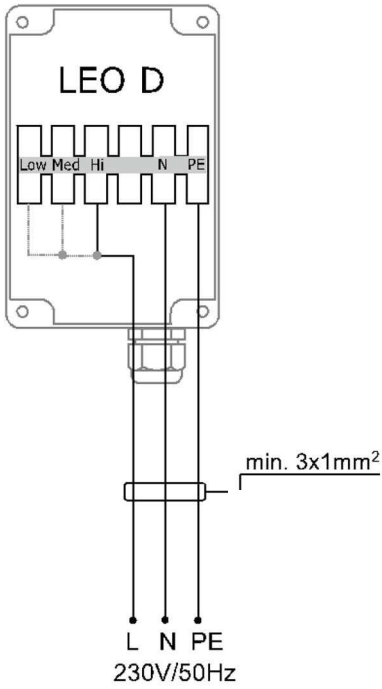

#### LEO D BMS

**When wiring the BMS Leo destratification fans- you 'Daisy Chain' them from one DRV module to the next - maximum cable length in between two units is 50 mtrs - cable size in yellow below**

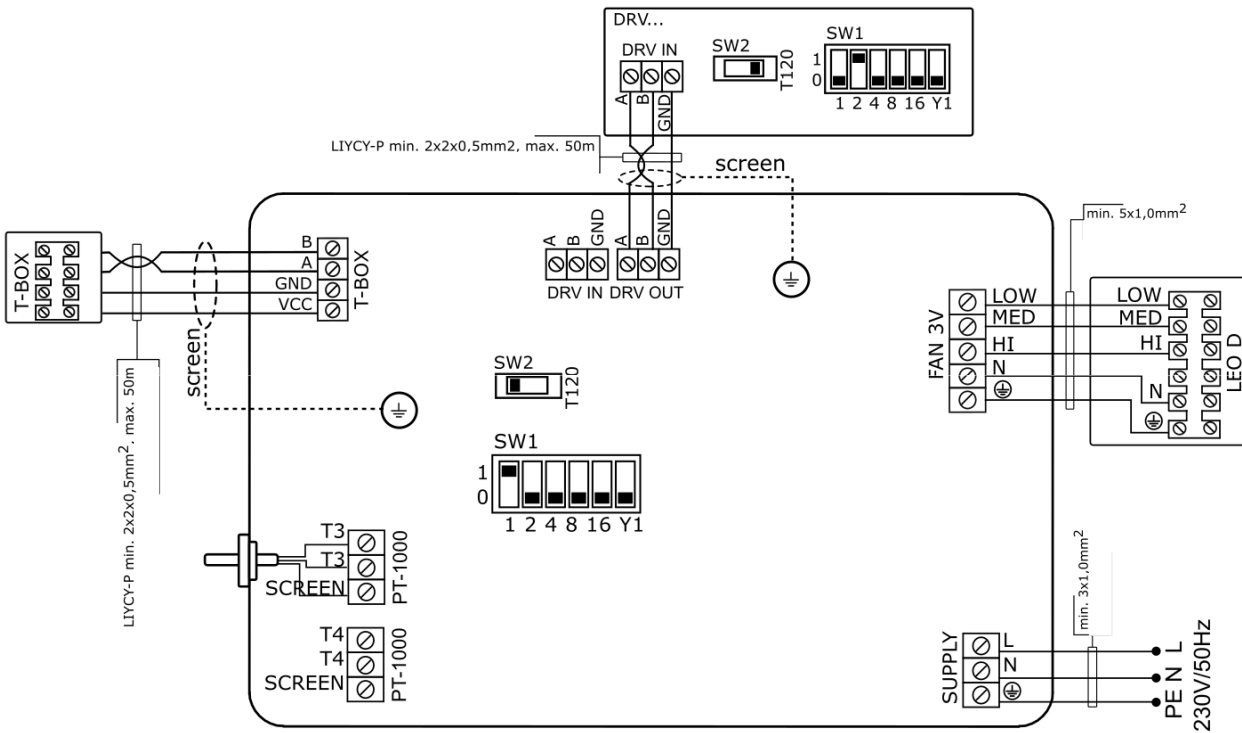

T-box – controller with touch screen connection  
 FAN 3V - 3-step fan connection  
 SUPPLY – supply connection

## 4. INSTALLATION

### 4.1. DISTANCE

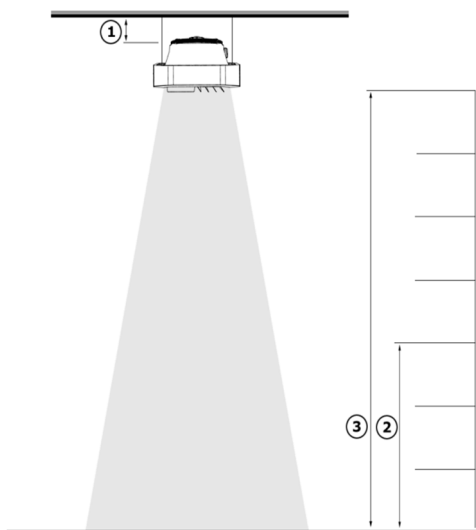

	LEO D / S	LEO D / L	LEO D / XL
①	min. 1m		
②	min. 6m		
③	max. 8 m*	max. 13 m*	max. 15 m*

\*with all blades directed downwards

In case of installation on surface which transfer vibrations is recommended to use vibration isolator.

### 4.2. METHODS OF INSTALLATION

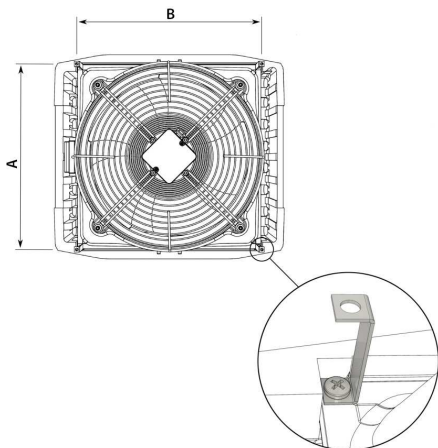

	LEO D S	LEO D L	LEO D XL
A	415	515	585
B	415	515	665

Under ceiling montage must be done using each (four) U-section profiles.

It is recommended that the mounting to the ceiling be executed keeping similar distance.

Unit can be hanged by pins. Instalation by ropes is not allowed.

Please mind distances of installation listed in paragraph 4.1.

## 5. START-UP AND OPERATION

### Start Up

- Before connecting the power supply check the correctness of connection of the fan motor and the controllers. These connections should be executed in accordance with their technical documentation.
- Before connecting the power supply check whether the mains voltage is in accordance with the voltage on the device data plate.
- The electrical system supplying the fan motor should be additionally protected with a circuit breaker against the effects of a possible short-circuit in the system.
- Starting the device without connecting the ground conductor is forbidden.

### Operation

- The device is designed for operation inside buildings, at temperatures above 0°C.
- The device must be inspected periodically. In the case of incorrect operation of the device it should be switched off immediately.

**It is forbidden to use a damaged device. The manufacturer bears no responsibility for damage resulting from the use of a damaged device.**

- For the time of performing inspection or cleaning the device, the electrical power supply should be disconnected.

## 6. SERVICE AND WARRANTY TERMS

**Please contact your dealer in order to get acquainted with the warranty terms and its limitation.**

In the case of any irregularities in the device operation, please contact the manufacturer's service department.

**The manufacturer bears no responsibility for operating the device in a manner inconsistent with its purpose, by persons not authorised for this, and for damage resulting from this!**

**Made in EU**

## 7. CONFORMITY WITH WEEE DIRECTIVE 2012/19/UE

Running a business without harming the environment and observing the rules of proper handling of waste electrical and electronic equipment is a priority for Flexiheat.

The symbol of the crossed out wheeled bin placed on the equipment, packaging or documents attached means that the product must not be disposed of with other wastes. It is the responsibility of the user to hand the used equipment to a designated collection point for proper processing. The symbol means at the same time that the equipment was placed on the market after August 13, 2005.

**For information on the collection system of waste electrical and electronic equipment, please contact the distributor.**

### **REMEMBER :**

- Do not dispose of used equipment together with other waste! There are financial penalties for this. Proper handling of used equipment prevents potential negative consequences for the environment and human health. At the same time, we save the Earth's natural resources, reusing resources obtained from the processing of equipment.







---

## **Declaration Of Conformity**

*Flexiheat hereby confirms that heating units*

- LEO D S / LEO D S BMS / LEO DT S
- LEO D L / LEO D L BMS / LEO DT L
- LEO D XL / LEO D XL BMS / LEO DT XL

*were produced in accordance to the following Europeans Directives*

1. **2014/30/UE** – *Electromagnetic Compatibility (EMC)*
2. **2006/42/WE** – *Machinery*
3. **2014/35/UE** – *Low Voltage Electrical Equipment (LVD)*
4. **2009/125/WE** – *Energy-related products (ErP 2015)*

*and harmonized norms ,with above directives*

**PN-EN ISO 12100:2012**    *Safety Of Machinery - General Principles For Design - Risk Assessment And Risk Reduction*

**PN-EN 60204-1:2018-12**    *Safety of machinery – Electrical equipment of machines – Part 1: General requirements*

**PN-EN 60034-1:2011**    *Rotating electrical machines — Part 1: Rating and performance*

**PN-EN 61000-6-2:2008**    *Electromagnetic compatibility (EMC). Generic standards. Immunity for industrial environments*

Gdynia, 14.01.2019  
Product Manager