



**FLEXIHEAT UK LTD**

[www.flexiheatuk.com](http://www.flexiheatuk.com)

01202 822221

# Installation, Use and Maintenance Manual for model

---

## **R2C 34**

---

Condensing boiler with integrated heat  
exchanger for domestic hot water side

**CE 0476**

R2C34-RAD-ING-Manuale-2101.1\_SKB1.3\_MIAB3013\_R7\_B3\_firm.H048D

# SUMMARY

**INTRODUCTION** ..... 4

## **1. INSTALLER SECTION** ..... 7

**1.1. INSTALLATION** ..... 8

1.1.1. GENERAL INSTALLATION WARNINGS ..... 8

1.1.2. BOILER LOCATION ENVIRONMENTAL REQUIREMENTS ..... 8

1.1.3. REFERENCE LEGISLATION ..... 9

1.1.4. UNPACKING ..... 10

1.1.5. OVERALL DIMENSIONS ..... 11

1.1.6. JIG ..... 11

1.1.7. FASTENING JIG ..... 11

1.1.8. POSITIONING AND MINIMAL TECHNICAL SPACES ..... 12

1.1.9. CIRCULATOR PREVALENCE/FLOW DIAGRAM ..... 14

1.1.10. HYDRAULIC CONNECTION ..... 15

1.1.11. SYSTEM FILLING ..... 16

1.1.12. FILLING THE CONDENSATE COLLECTION SIPHON ..... 17

1.1.13. ANTI-FREEZE PROTECTION ..... 18

1.1.14. GAS CONNECTION ..... 19

1.1.15. ELECTRICAL CONNECTION ..... 19

1.1.16. OPTIONAL ELECTRICAL CONNECTIONS ..... 20

1.1.17. FUME EXHAUST FITTINGS ..... 22

1.1.18. TYPES OF FUME EXHAUST SYSTEMS ..... 23

## **2. SUPPORT CENTER SECTION** ..... 27

**2.1. FIRST START-UP** ..... 28

2.1.1. PRELIMINARY OPERATIONS FOR FIRST START-UP ..... 28

2.1.2. BOILER COMMISSIONING ..... 29

2.1.3. CO2 VALUE CHECK AND CALIBRATION ..... 30

2.1.4. ACCESSING AND PROGRAMMING THE PARAMETERS ..... 31

2.1.5. MIAB3013 PARAMETERS TABLE ..... 34

2.1.6. ELECTRIC FAN FREQUENCY/HEAT CAPACITY DIAGRAM ..... 41

**2.2. MAINTENANCE** ..... 42

2.2.7. GENERAL MAINTENANCE WARNINGS ..... 42

2.2.8. TECHNICAL DATA ..... 43

2.2.9. TECHNICAL ASSEMBLY ..... 45

2.2.10. HYDRAULIC BOARD ..... 46

2.2.11. WIRING DIAGRAM ..... 47

2.2.12. ACCESSING THE BOILER ..... 48

2.2.13. ACCESSING THE ELECTRONIC BOARD ..... 49

2.2.14. SYSTEM EMPTYING .....	50
2.2.15. FAULT SIGNALLING CODES .....	51
2.2.16. ACTIVE FUNCTIONS SIGNALLING CODES .....	54
2.2.17. GAS TYPE TRANSFORMATION .....	55

## **3. USER SECTION 57**

<b>3.1. USE .....</b>	<b>58</b>
3.1.1. GENERAL USE WARNINGS .....	58
3.1.2. CONTROL PANEL .....	59
3.1.3. DISPLAY ICONS .....	60
3.1.4. INFO MENU DISPLAY DATA .....	61
3.1.5. START-UP .....	62
3.1.6. OPERATING MODE .....	62
3.1.7. INFORMATIONAL NOTE ON ANTI-FREEZE FUNCTION .....	63
3.1.8. SYSTEM FILLING .....	64
3.1.9. FAULT SIGNALLING CODES .....	65
3.1.10. ACTIVE FUNCTIONS SIGNALLING CODES .....	67
3.1.11. FAST H2O FUNCTION .....	67
3.1.12. MAINTENANCE .....	68
3.1.13. COVER CLEANING .....	68
3.1.14. DISPOSAL .....	68

# INTRODUCTION

### WARNING

Before starting any operation it is mandatory to read this instruction manual, in relation to the activities to be carried out as described in each relevant section. Proper operation and optimal performance of the boiler are ensured by strict compliance with all the instructions given in this manual.

The installation, use and maintenance manual is an integral and essential part of the product and must be delivered to the user.

### MANUAL USERS

The manual users are all those who install, use and maintain the boiler.

The boiler must be used and accessed only by qualified operators that fully read and understood the use and maintenance manual, paying particular attention to the warnings.

### READING AND SYMBOLS OF THE MANUAL

To ease the understanding of this manual, recurrent symbols where used, in particular:

- › On the outer margin of the page is placed a thumb index indicating the type of user to which the instructions in that section address.
- › The titles are differentiated by thickness and size in accordance with their hierarchy.
- › The images contain important parts described in the text, marked with numbers or letters.
- › (See chap “chapter name”): this entry indicates another section in the Manual that you should refer to.
- › Device: this term is used referring to the boiler.



### DANGER

*It identifies an information related to a general danger that if not complied with, may cause serious personal damage or even death.*



### ATTENTION

*It identifies an information that if not complied with may cause small or medium level lesions to the person or serious deterioration to the boiler.*



### WARNING

*It identifies a precaution information that must be observed in order to avoid damaging the machine or parts of it.*

### MANUAL STORAGE

The manual must be carefully stored and replaced in case of deterioration and/or low legibility.

If you misplace the use and maintenance manual, you can request it from the Technical Support Centre giving the serial number and model of the boiler indicated on the plate placed on the right side of its casing.

### MANUFACTURER WARRANTY AND RESPONSIBILITY

The technical and functional features of the device are ensured by its use in compliance:

1. with the use and maintenance instructions contained in the manuals accompanying the product, the content of which the customer certifies that he is aware;
2. with the conditions and purposes to which assets of the same type are intended.

For more information on the warranty validity, its duration, the obligations and the exemptions, please consult the First start-up certificate attached to this manual.

The manufacturer reserves:

- › the right to modify the tools and relative technical documentation without any obligation to third parties; neither will the company be held responsible for any inaccuracies in this handbook deriving from printing or translation errors;
- › the material and intellectual ownership of this manual and forbids its distribution and duplication, even partial, without prior written authorization.

### PRODUCT CONFORMITY

**Flexiheat** declares that its gas boilers comply with the European Directives and with the requirements provided in the European standards below:

- › Eco-design Directive 2009/125 CE,

- › Energy labeling Directive 2010/30/CE,
- › Regulation EU 811/2013,
- › Regulation EU 813/2013,
- › Regulation EU 2016/426,
- › Electromagnetic compatibility Directive 2014/30/CE,
- › Performance Directive 92/42/CE,
- › Low voltage Directive 2014/35/CE.

The materials used such as copper, brass, stainless steel create a homogeneous, compact and functional assembly, easy to install and manage. In its simplicity, the boiler is equipped with all accessories necessary to render it a veritable independent heating unit. All boilers are tested and delivered with a quality certificate signed by the tester.



# 1. INSTALLER SECTION

The installation operations described in this section should be performed only by qualified personnel, having the appropriate technical training in the field for the installation and maintenance of components of civil and industrial domestic hot water production and heating plants.

## 1.1. INSTALLATION

### 1.1.1. GENERAL INSTALLATION WARNINGS



#### ATTENTION

*This machine may be used only for the purpose for which it has been designed: heat water to a temperature below boiling point at atmospheric pressure. Any other use is considered wrong and dangerous. The manufacturer is excluded from any contractual or out of contract responsibility for damage caused to people, animals or property due to errors during installation.*



#### ATTENTION

*This boiler should be installed only by qualified personnel, having the appropriate technical training in the field for the installation and maintenance of components of civil and industrial domestic hot water production and heating plants.*



#### ATTENTION

*After having removed the packing, make sure the equipment is intact. In case of doubt, do not use the equipment and contact the supplier.*

**BEFORE INSTALLING THE BOILER, THE INSTALLER MUST MAKE SURE THAT THE FOLLOWING CONDITIONS ARE MET:**

- › The device is connected to a heating plant and a water supply network appropriate for its power and performance.
- › The location must be properly vented through an air vent.
- › The air vent must be placed at floor level to prevent it from being obstructed, protected by a grid that does not hamper the useful section of passage.

- › The device is suitable for use with the type of gas available by checking the boiler data plate (placed on the inner side of the front casing).
- › Make sure that the tubes and couplings are perfectly sealed, without any gas leaks.
- › Make sure that the grounding system works properly.
- › Make sure that the electrical systems is suitable for the maximum power absorbed by the equipment, value indicated on the data plate.

### 1.1.2. BOILER LOCATION ENVIRONMENTAL REQUIREMENTS

The device's installation location should be vented due to the presence of threaded joints on the gas adduction line. The location should be therefore provided with vents as to ensure air exchange, with output grid in the natural accumulation area of eventual gas losses.



#### WARNING

*DO NOT install the boiler in a technical compartment near a swimming pool or a laundry, to avoid that the combustion air is exposed to chlorine, ammonia or alkaline agents that may worsen the corrosion phenomenon of the heat exchanger. Failure to observe this caution will void the warranty of the heat exchanger.*

**THIS BOILER HAS BEEN DESIGNED FOR OUTDOOR INSTALLATION IN A PARTIALLY PROTECTED**

LOCATION (SEE FIG.2 AT CHAPTER 'POSITIONING AND MINIMAL TECHNICAL SPACES').

THIS BOILER IS ABLE TO OPERATE IN A PARTIALLY PROTECTED PLACE, WITH SURROUNDING TEMPERATURES WITHIN A MIN. OF -10 °C AND A MAX. OF 60 °C.



**WARNING**

*If the temperature in the boiler installation location goes below -10° centigrades, please fill the plant with anti-freeze liquid and insert and electrical resistances kit (see chapter 'ANTI-FREEZE PROTECTION').*



**WARNING**

*The manufacturer will not be held responsible for damages caused by incorrect installation not in conformity with the over mentioned instructions and not protected adequately from the freeze.*

---

### 1.1.3. REFERENCE LEGISLATION

The installation must be realized according to the requirements of current legislation and in compliance with local technical regulations, according to the indications of the good technique.

## 1. INSTALLATION

### 1.1.4. UNPACKING



**WARNING**

*Please unpack the boiler just before installing it. The Company is not responsible for the damages caused to the device due to incorrect storage.*



**WARNING**

*The packing elements (cardboard box, wooden crate, nails, fasteners, plastic bags, expanded polystyrene, etc.) must be kept out of the reach of children as they may be dangerous. Therefore they should be dismantled suitably differentiating them in accordance with the standards in force.*

To unpack the boiler, proceed as follows:

- > Place the packed boiler on the floor (fig. 1-A) and remove the fasteners opening the four flaps of the box outwards.
- > Turn the boiler at 90° holding it with your hand (fig. 1-B).
- > Lift the box (fig. 1-C) and remove the guards (fig. 1-D).

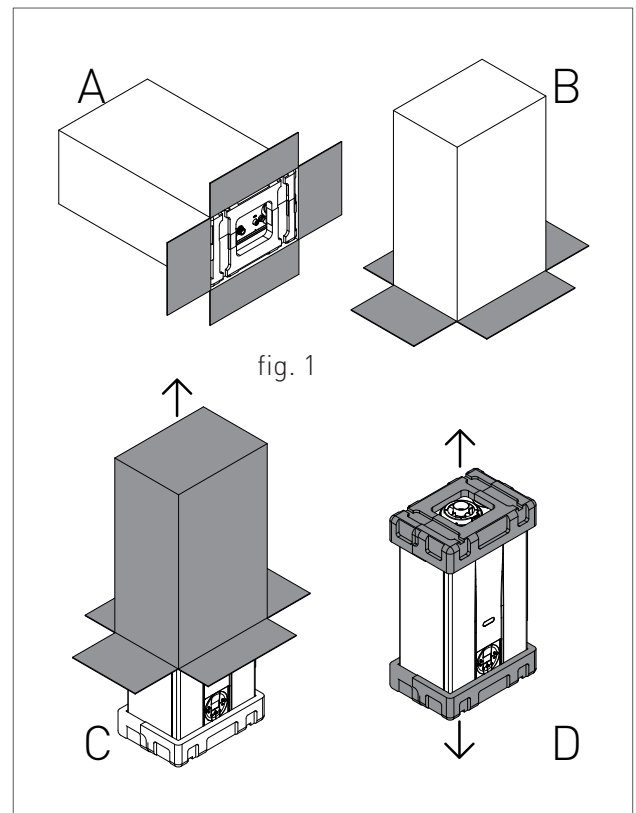

1.1.5. OVERALL DIMENSIONS

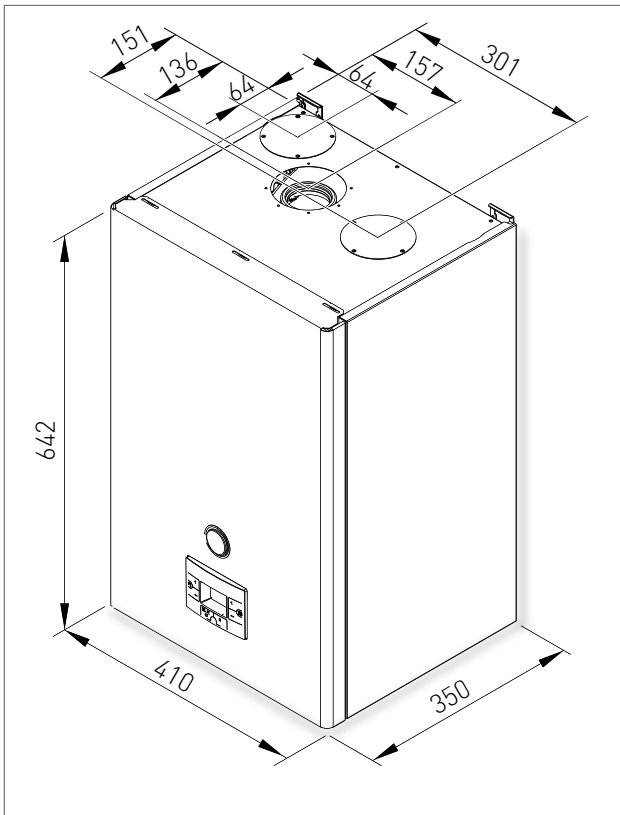

1.1.7. FASTENING JIG

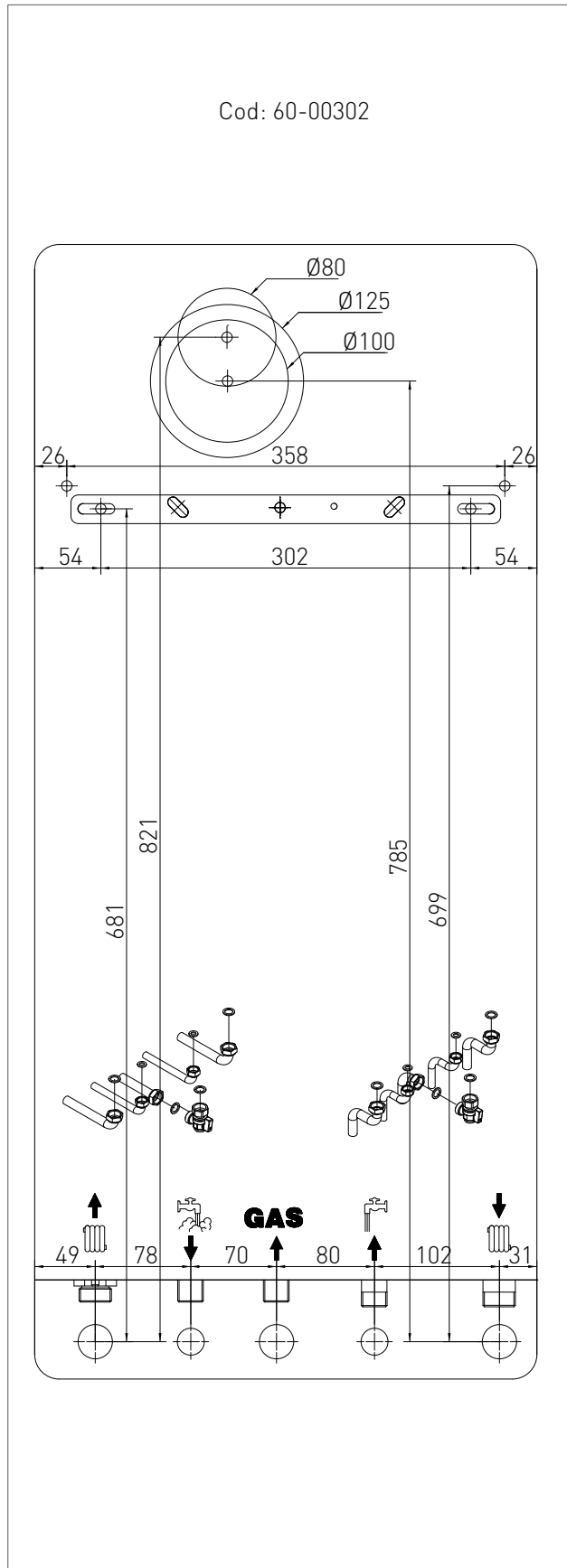

1.1.6. JIG

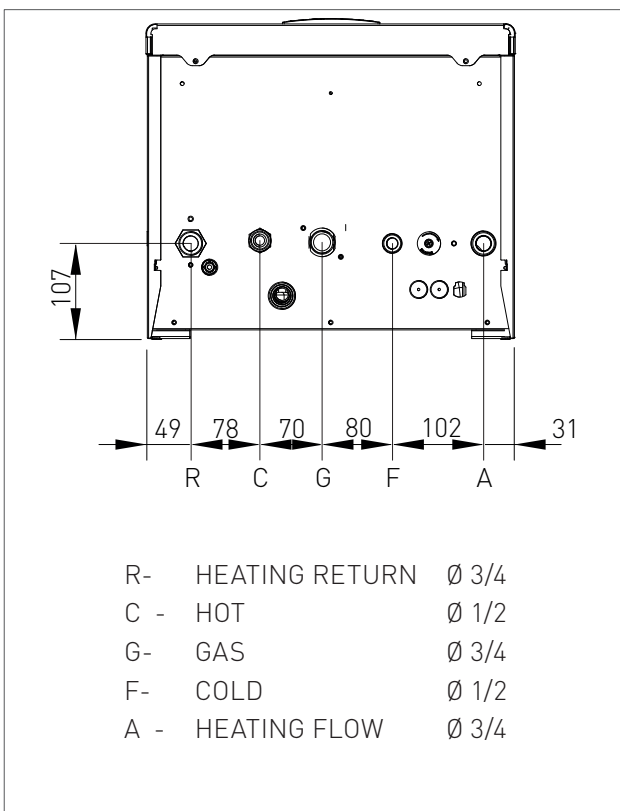

1. INSTALLATION

1.1.8. POSITIONING AND MINIMAL TECHNICAL SPACES

The boiler must be installed only on a vertical solid wall, able to sustain its weight.

In order to allow the access inside the boiler for maintenance operations, you have to respect the minimum technical spaces indicated in figure 1.

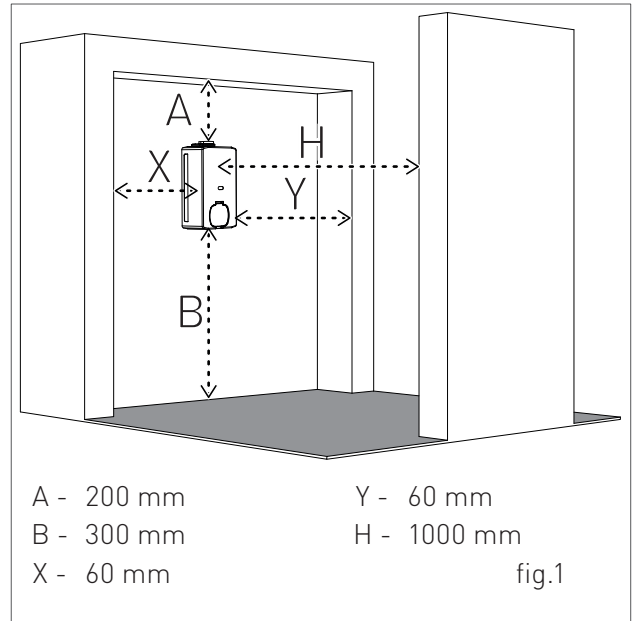

It is allowed an outdoor installation in a partially protected location (i.e. shelter, balcony) that respect the minimum measure indicated in figure 2.

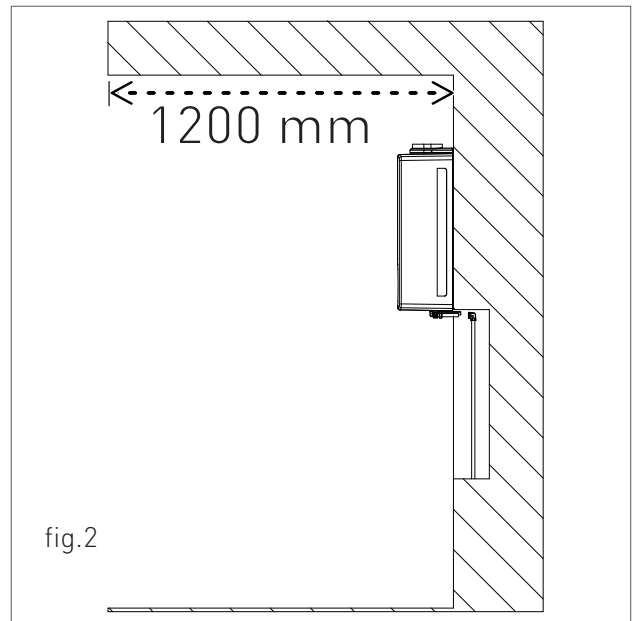

## 1. INSTALLATION

To facilitate the installation, the boiler is provided with a jig that allows setting in advance the connections to the tubes offering you the possibility of connecting the boiler to completed masonry works.

For machine positioning, proceed as follows (see fig. 3):

1. Trace a line using a spirit level (min. length 25 cm) on the installation wall.
2. place the top of the jig along the traced line respecting the distances of the water connections; then mark the two points to insert the two knobs or the fasteners, then trace the points for the fume exhaust fittings;
3. remove the jig and drill the wall;
4. hang the device using the knobs or the bracket and perform the connections.

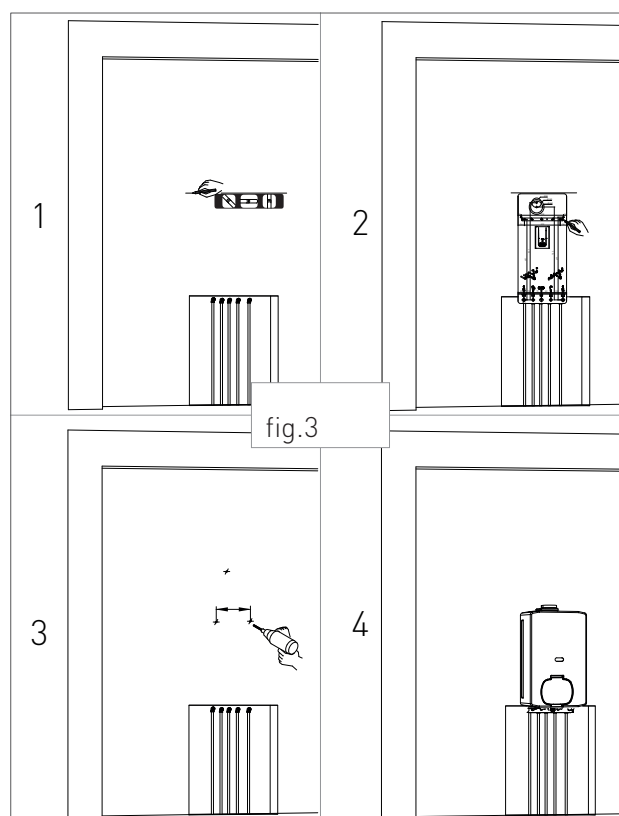

1. INSTALLATION



**WARNING**

Make sure, using a level, that the boiler is properly inclined being levelled (see fig.1) so as to allow the condense to drain.

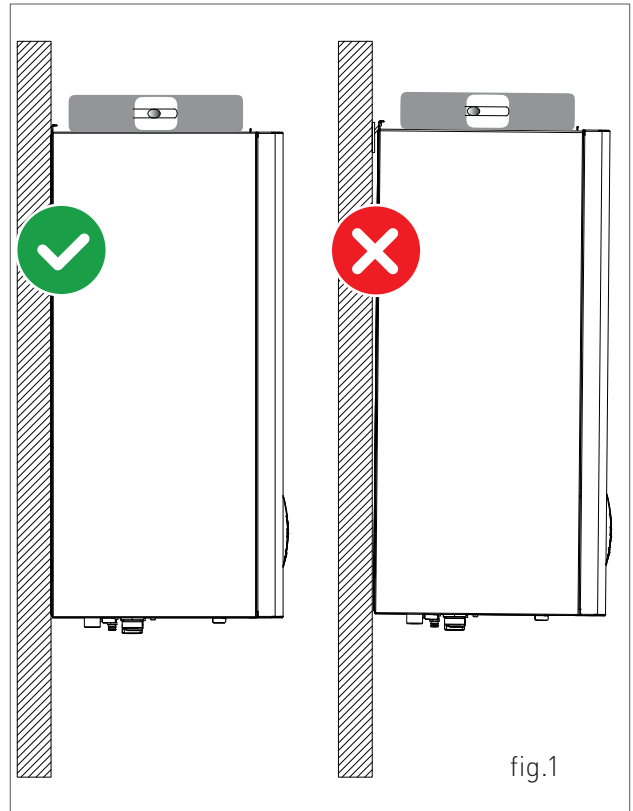
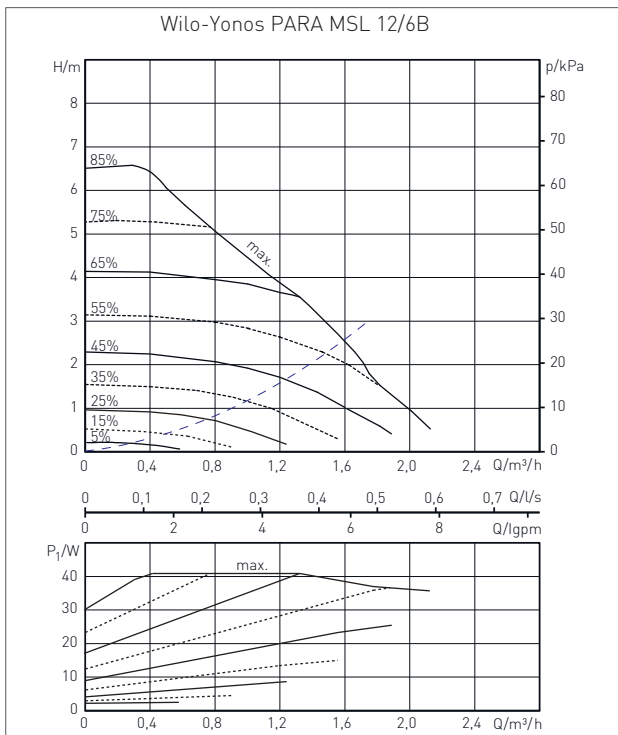

fig.1

1.1.9. CIRCULATOR PREVALENCE/  
FLOW DIAGRAM



--- Appliance Loss

## 1. INSTALLATION

### 1.1.10. HYDRAULIC CONNECTION



#### DANGER

*Make sure that the tubes of the water and heating plant are not used as grounding system for the electrical plant. There are not suitable for such use.*



#### WARNING

*To prevent voiding the warranty and to ensure the proper operation of the boiler, please wash the plant (if possible when hot) with suitable pickling or descaling solutions in order to remove the impurities coming from tubes and radiators.*



#### WARNING

*If the boiler is installed in a hydrostatic position lower than those of the user devices (radiators, fan coils, etc.), mount the shut-off valves on the domestic water heating circuit to ease the performance of the maintenance operations if it is necessary only to empty the boiler.*



#### WARNING

*When connecting the equipment to water supply, avoid excessive bending and recovery operations from any off axis positioning that may damage the tubes causing leaks, malfunction or early wear.*



#### WARNING

*In order to avoid any vibrations and noises, do not use tubes with small diameters or elbows with small radius and significant cut-off of the passage sections.*



#### WARNING

*Connect the boiler safety drains to a discharge funnel. The manufacturer is not responsible for any floods due to safety valve opening in case of plant overpressure.*

### DOMESTIC CIRCUIT

In order to prevent limestone build-up and damages to the domestic water heat exchanger, the hardness of the domestic supply water should not exceed 15 °f. However, please check the characteristics of the water used and install suitable treating devices.

The heat exchanger coil cleaning frequency depends on the hardness of the supply water and on the presence of solid residues or impurities inside the water that are often present in case of recently installed plants. Based on the characteristics of the infeed water, you should install suitable water treating devices, for residues presence please install a line filter.

The pressure of the cold infeed water should be between 0.5 and 6 bar. In case of greater pressure values, please install a pressure reducer upstream from the boiler.

### HEATING CIRCUIT

In order to avoid any scale or deposits on the primary exchanger, the hardness of the heating circuit infeed water should not exceed 25 °f. However, please check the characteristics of the water used and install suitable treating devices.

This treatment is mandatory if frequent episodes of return water or partial or total emptying of the plant occur.



#### WARNING

*In case the boiler is installed as part of a low temperature circuit, please install a safety thermostat on the heating flow, which can stop the boiler activity in case of high heating flow temperature. The company assumes no liability for damage caused to persons or for failure to comply with these instructions.*

## 1. INSTALLATION

### 1.1.11. SYSTEM FILLING



**WARNING**

*For system filling use only clean tap water.*



**WARNING**

*If the system is filled by adding ethylene glycol-type chemical agents you have to install on the loading system a hydraulic trip unit in order to separate the heating circuit from the domestic circuit.*

Before powering up the boiler, fill the system as follows:

1. slightly loosen the cap of the circulator jolly valve [1-fig. 1] to release the air from the system;
2. slightly loosen the cap of the jolly valve placed on the top of the condensing block (fig. 3) to release the air form the top of the system;
3. open the feeding tap "R" (fig. 2);
4. release all the air;
5. use pressure gauge "M" (fig. 2) to make sure that the system pressure reaches 1.2 bar (fig. 4);
6. after performing this operation, make sure that the loading tap "R" (fig. 2) is properly closed.

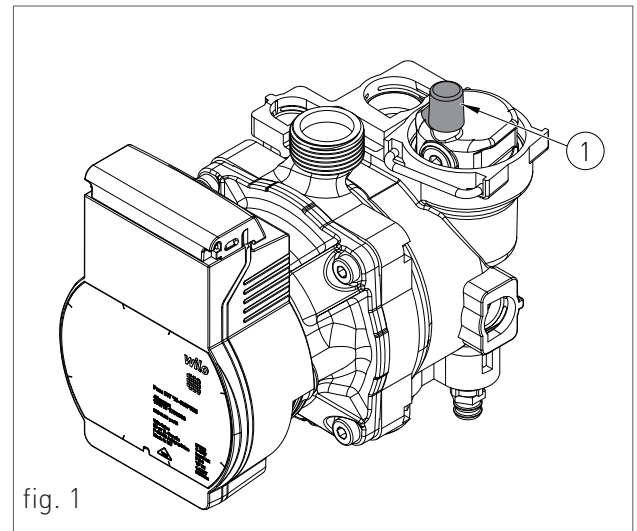

fig. 1

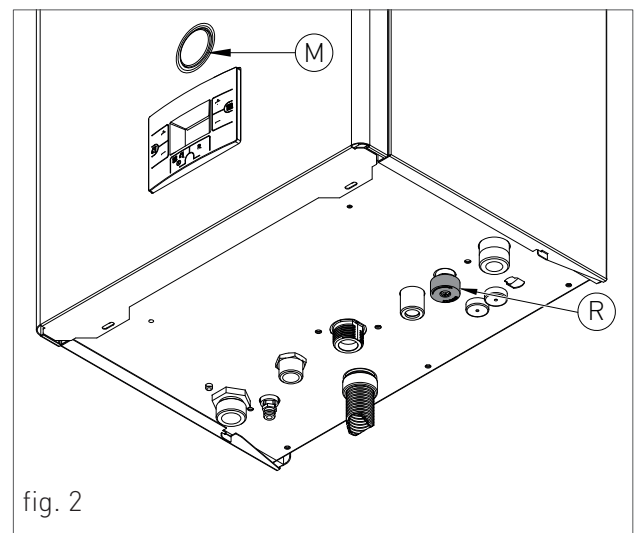

fig. 2

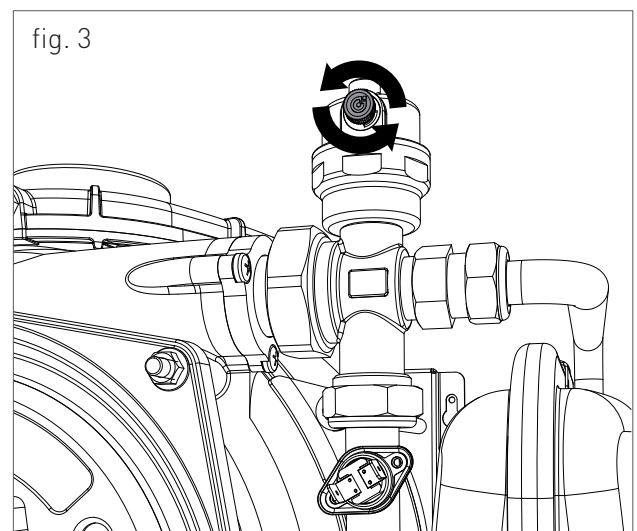
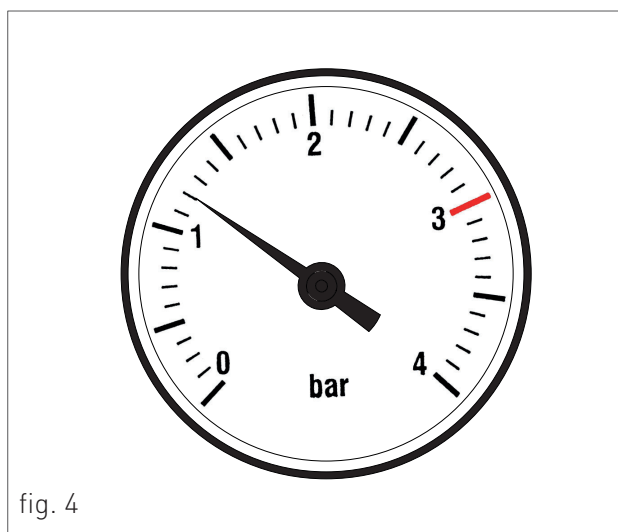

fig. 3

7. open the air relief valves of the radiators and check the air removal process. When the water starts to leak close the radiators air relief valves.
8. if after performing these operations you observe a decrease of the water pressure inside the system, open once again the loading tap "R" until the pressure gauge indicates the value of 1.2 bar (fig. 4).



### 1.1.12. FILLING THE CONDENSATE COLLECTION SIPHON

Before starting the boiler you have to fill the condensate collection siphon in order to avoid flue reflux through the siphon.

Fill the condensate collection siphon as follows (see fig. 5):

- › With a glass pour the water in the heat exchanger's flue exhaust duct outlet (see fig. 5), up to fill the condensate trap to the highest point "T" (fig. 5);
- › Connect the dedicated flexible condensate draining tube to a waste disposal system. The condensate can be drained directly in the sewerage system by inserting an easily serviceable siphon.

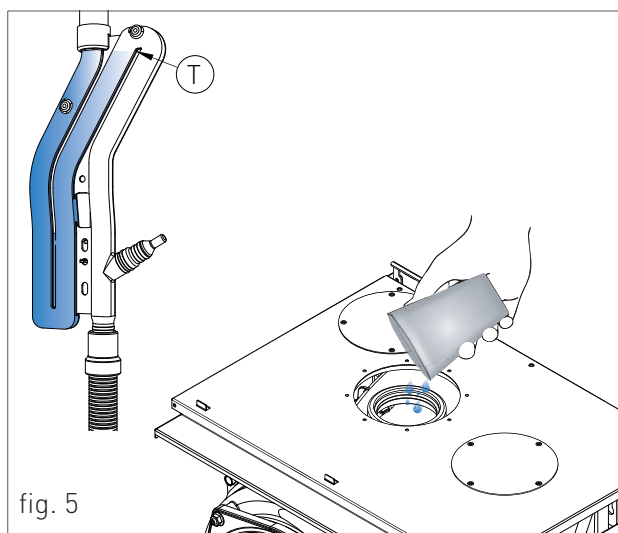

## 1. INSTALLATION

### 1.1.13. ANTI-FREEZE PROTECTION

The boiler is protected against freezing thanks to the electronic board preparation with functions that start the burner and heat the concerned parts when their temperature goes below the minimum pre-set values, protecting the boiler up to an external temperature of -10 °C.

The device starts when the hot water temperature goes below 5 °C, automatically starting the burner until the water reaches the temperature of 30 °C.

The system starts even if on the display appears "OFF", as long as the boiler is connected to the power (230 V) and gas supply.

For long periods of standby, please empty the boiler and the plant.

If the temperature goes below -10° centigrades, please fill the plant with anti-freeze liquid (CLEANPASS FLUIDO AG cod. 98716LA) and insert and electrical resistances kit (cod. 82259LP).

#### DILUTION PERCENTAGE OF CLEANPASS FLUIDO AG

ANTIFREEZE - ETHYLENE GLYCOL (%) VOLUME	TEMPERATURE FREEZING POINT (°C)
20	-7.5
30	-13
35	-18
40	-22.5
45	-28
50	-33.5
55	-42
60	-50

RECOMMENDED MINIMUM PERCENTAGE OF GLYCOL : 20 %

## 1. INSTALLATION

### 1.1.14. GAS CONNECTION



#### DANGER

*In order to connect the gas connector of the boiler to the supply pipe use a stop seal of an appropriate size and material. The use of hemp, teflon tape or similar materials is strictly forbidden.*

#### **BEFORE PERFORMING THE GAS CONNECTION, MAKE SURE THAT:**

- › the gas adduction line complies with the standards and regulations in force;
- › the tubing's section suits the requested capacity and its length;
- › the tubing is equipped with all safety and control devices required by the standards in force;
- › the internal and external seals of the gas infeed plant are checked;
- › the device is suitable for use with the type of gas available by checking the boiler data plate (placed on the inner side of the front casing. If they do not match you must take the necessary measures to adapt the boiler to another type of gas (see chapter GAS TRANSFORMATION);
- › the gas supply pressure falls within the values indicated on the data plate.

### 1.1.15. ELECTRICAL CONNECTION



#### DANGER

*The equipment is electrically safe only if it is properly connected to an efficient grounding system, performed in compliance with the safety standards in force. You should check this essential safety requirement. If in doubt, request an accurate check of the electrical system performed by qualified staff, as the manufacturer is not responsible for any damages caused by lack of grounding system.*

- › Make sure that the electrical systems is suitable for the maximum power absorbed by the equipment, value indicated on the data plate.
- › make sure that the cables section is appropriate for the maximum power absorbed by the equipment and that it is however not lower than 1 mm<sup>2</sup>.
- › The equipment works with alternating current of 230 V and 50 Hz.



#### WARNING

*Make sure that the phase and neutral cables connection is performed in compliance with the wiring diagram (see chapter WIRING DIAGRAM).*



#### WARNING

*It is strictly forbidden the use of adaptors, multiple plugs and/or extensions for the general power supply of the equipment from the electrical network.*

## 1. INSTALLATION

### 1.1.16. OPTIONAL ELECTRICAL CONNECTIONS

The cables should be inserted inside the boiler using the cable glands 'P1' and 'P2' placed under the board (see fig. 1). Make a hole on the cable gland, smaller than the cable diameter, to make sure that the air cannot pass through.

To wire the optionals below:

- **(SE) EXTERNAL TEMPERATURE PROBE COD. 73518LA**

- **(TA) ENVIRONMENT THERMOSTAT**

- **(CR) REMOTE CONTROL OPEN THERM COD. 40-00017**

use the electronic board placed inside the control panel as follows:



**DANGER**

*Cut off the voltage from the main switch.*

- › remove the boiler's front casing (refer to chapter ACCESSING THE BOILER);
- › remove the crankcase of the control panel (see chapter ACCESSING THE ELECTRONIC BOARD).

- For the external temperature Probe connect the two non-polarized conductors to the contacts of the terminal M0904 (see 'SE' fig. 2).
- For the environment Thermostat or Remote control, first remove the bridge on the contacts of the terminal M0904 and then connect the two non-polarized conductors of the environment Thermostat or Remote control (see 'TA' or 'CR' fig. 2).

After performing these operations, remount the crankcase and the front casing.

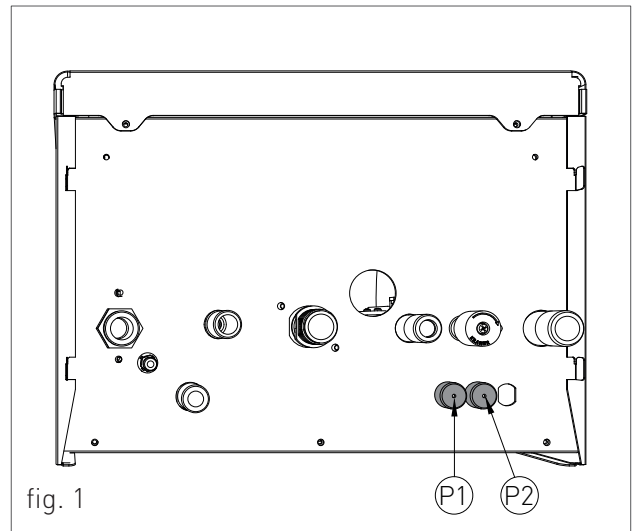

fig. 1

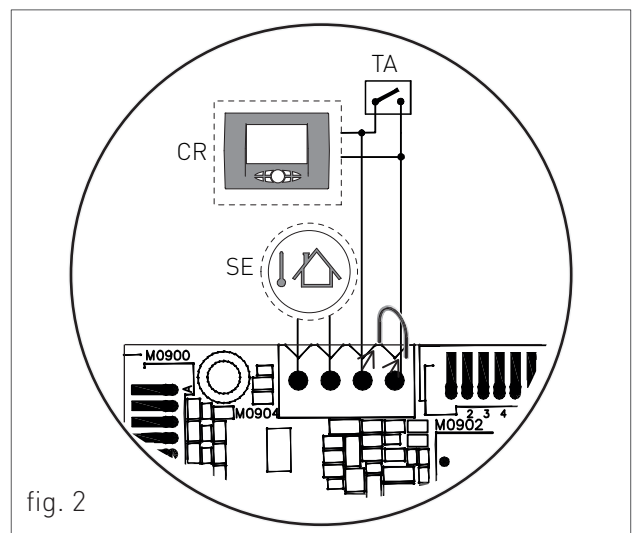

fig. 2

## 1. INSTALLATION

To wire the optionals below:

- (TP) DOMESTIC HOT WATER PRE-HEATING DEACTIVATION TIMER
- (SVZ) CONTROL BOARD FOR AREA VALVES
- (AG) AUXILIARY RELAY FOR GENERIC DEVICE. MAXIMUM CURRENT 3A WITH 250VAC (SEE RELAY MANAGEMENT AT PARAMETER P24)

use the electronic board placed inside the control panel as follows:

- > remove the boiler's front casing (refer to chapter ACCESSING THE BOILER).
- > remove the crankcase of the control panel (see chapter ACCESSING THE ELECTRONIC BOARD).
- > after removing the crankcase, connect the items below to the electronic board (see fig. 1):

After performing these operations, remount the crankcase and the front casing.



### DANGER

*Cut off the voltage from the main switch.*

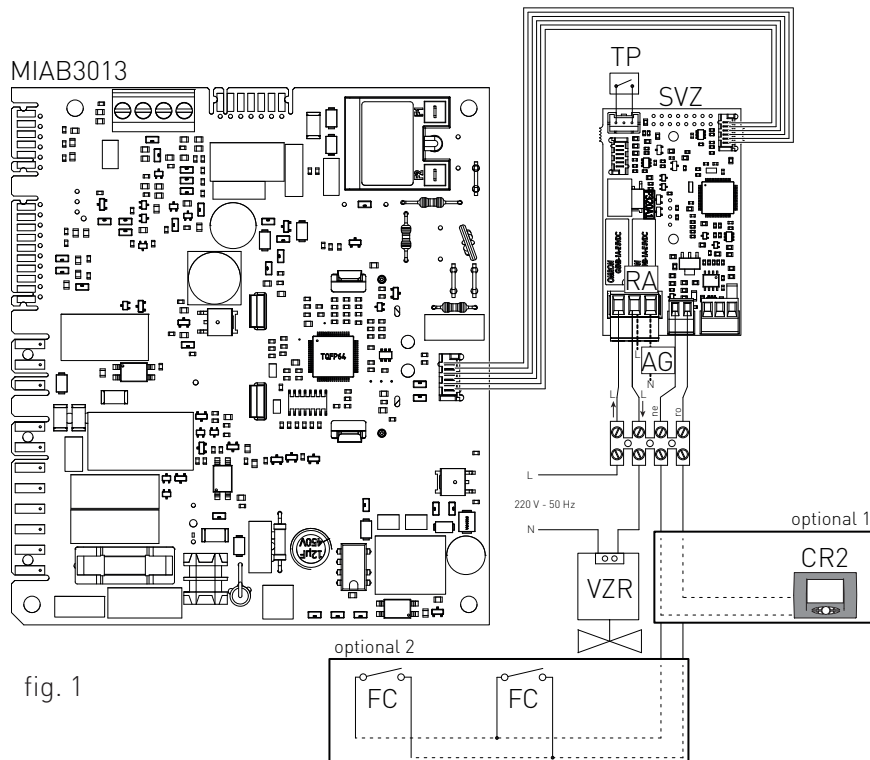

fig. 1

RA:	AUXILIARY RELAY	CR2:	CONTROLLO REMOTO SLAVE
VZR:	REMOTE CONTROLLED AREA VALVE	NE:	BLACK
FC:	AREA VALVES LIMIT SWITCH	RO:	RED

## 1. INSTALLATION

### 1.1.17. FUME EXHAUST FITTINGS



#### WARNING

*In order to ensure proper operation and efficiency of the device you have to connect the boiler fume exhaust fitting to the fume exhaust duct using appropriate polypropylene flue fittings for condensing boilers.*



#### WARNING

*You cannot use traditional flue fittings for the discharge ducts of the condensing boilers, nor vice versa.*



#### WARNING

*For fumes exhaust and condensate collection, please follow the technical standards in force.*

- › For all discharge ducts, with regard to the fumes path, you should provide an uphill slope (outwards) so as to favour the reflux of the condensate towards the combustion chamber, suitably realized to collect and drain acid condensate.
- › For all air suction ducts, with regard to the air path, you should provide an uphill slope (towards the boiler) so as to avoid the protrusion inside the duct of rain water, dust or foreign objects.
- › In case of horizontal co-axial system installation, correctly place the horizontal co-axial terminal suitably realized to respect the slopes inside the fumes duct and to protect the air suction duct from adverse weather conditions.
- › In order to discharge the fumes through a fumes exhaust duct carefully follow the technical standards in force.
- › Make sure that the discharge tube does not protrude inside the fumes exhaust duct, stop before it reaches the inner surface of the latter.

- › The discharge duct must be perpendicular with the opposite internal wall of the chimney or of the fumes exhaust duct (fig. 1).

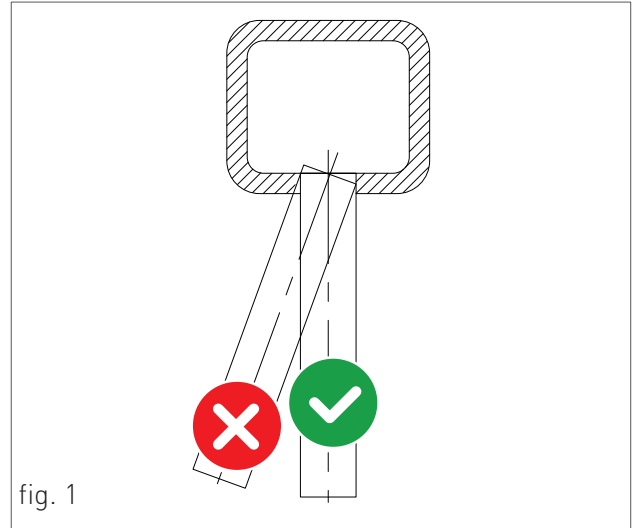
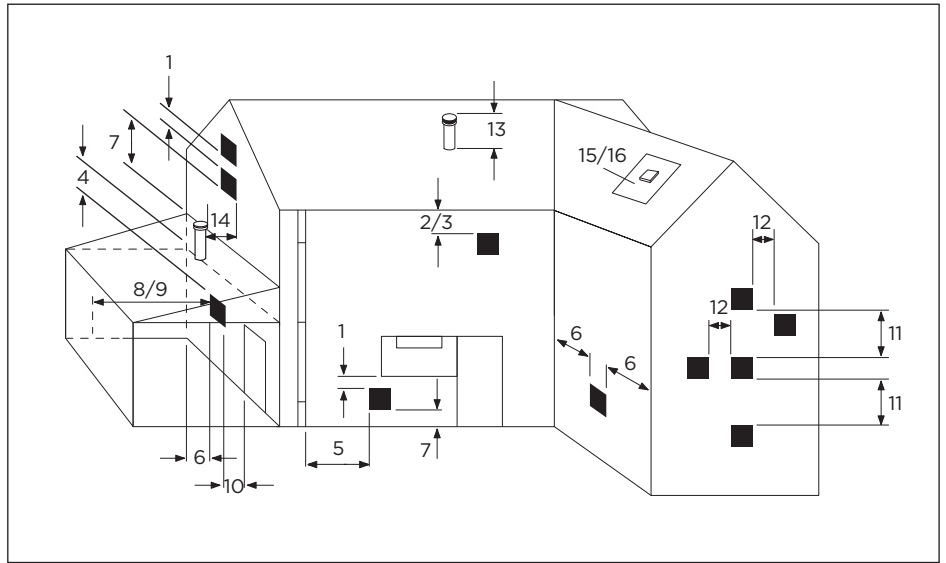

fig. 1

# FLUE EXIT SITING.

Following are the basic flue regulations as required by part 'J' of the 2010 building regulations. Please do your own due diligence to ensure these are up to date



FLUE TERMINAL POSITION	MIN. SPACING
1. Directly below, above or alongside an opening window, air vent or other ventilation opening.	300mm (12")
2. Below guttering, drain pipes or soil pipes.	75mm (3")
3. Below eaves.	200mm (8")
4. Below balconies or car port roof.	200mm (8")
5. From vertical drain pipes or soil pipes.	150mm (6")
6. From an internal or external corner or to a boundary alongside the terminal.	300mm (12")
7. Above ground, roof or balcony level.	300mm (12")
8. From a surface or a boundary facing a terminal.	600mm (24")
9. From a terminal facing a terminal.	1200mm (48")
10. From an opening in a car port (eg. door or window) into dwelling.	1200mm (48")
11. Vertically from a terminal on the same wall.	1500mm (60")
12. Horizontally from a terminal on the wall.	300mm (12")
<b>VERTICAL FLUES</b>	
13. Above the roof pitch with roof slope of all angles. Above flat roof.	300mm (12") 300mm (12")
14. From a single wall face. From corner walls.	300mm (12") 300mm (12")
15. Below velux window.	2000mm (79")
16. Above or side of velux window.	600mm (24")

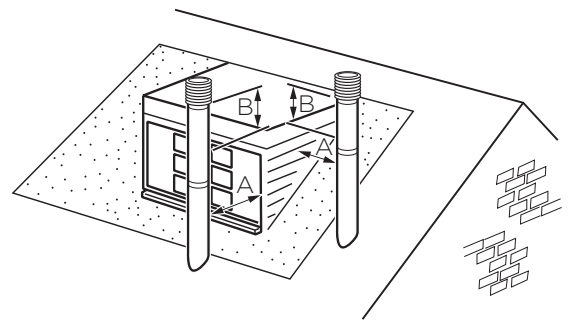
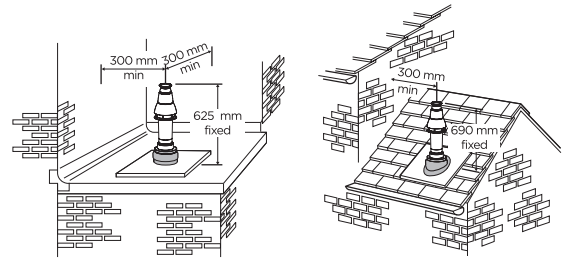

If chimney penetrates dotted area such that A is less than 300mm, B shall not be less than 300mm.

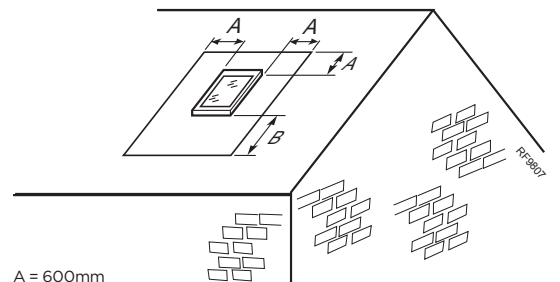

A = 600mm  
B = 2000mm

The flue terminal shall not penetrate the shaded area of the roof.

1.1.18. TYPES OF FUME EXHAUST SYSTEMS

**KIT AK 50 - HORIZONTAL CO-AXIAL SYSTEM  
Ø80/125 INTERNAL POLYPROPYLENE DUCT  
ADJUSTABLE AT 360°.**

It allows fumes discharge and air intake from external wall.

Suitable only for condensing boilers.

It allows fuel gas discharge and air intake for combustion through co-axial ducts, the external one for air intake, the plastic internal one for fumes discharge.

PLEASE SEE THE MAXIMUM DISCHARGE LENGTH IN THE TABLE IN CHAPTER "TECHNICAL DATA".

The maximum discharge length (or linear reference length) can be calculated summing the length of the linear tube and that equivalent to each additional curve with respect to the first.

Subsequent addition of a curve is similar to adding a linear length of tube according to the indications below:

co-axial curve Ø80/125 at 90° = 0.8 m

co-axial curve Ø80/125 at 45° = 0.5 m

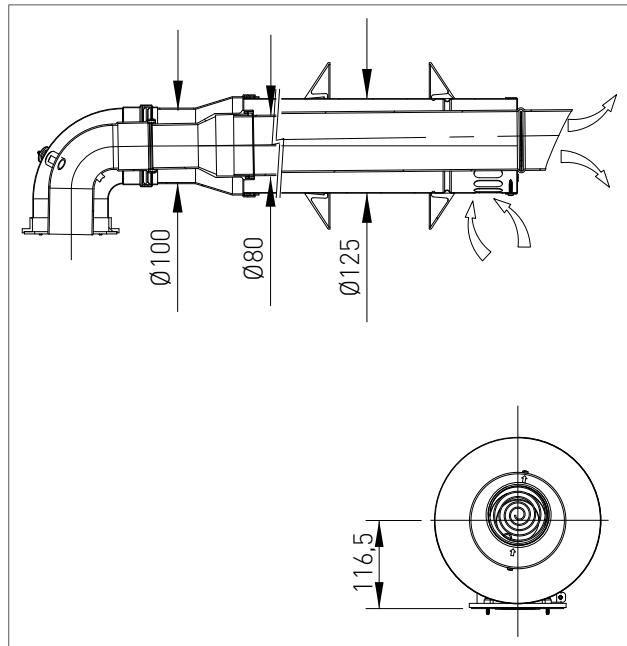
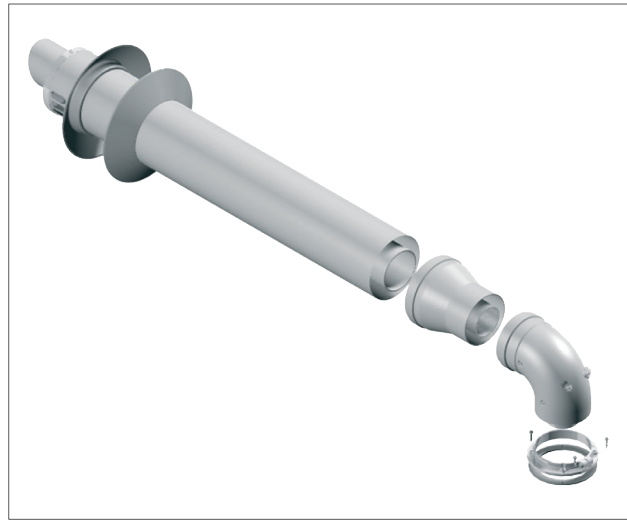

1. INSTALLATION

**KIT H – HORIZONTAL TWIN PIPE FLUE KIT Ø80/80, IN POLYPROPYLENE, ADJUSTABLE AT 360°.**

The twin pipe allows flue discharge through the flue exhaust duct and air intake from outside.

Suitable only for condensing boilers.

It allows discharging fuel gas and air suctioning for combustion through two separated ducts.

PLEASE SEE THE MAXIMUM DISCHARGE AND INTAKE LENGTH IN THE TABLE IN CHAPTER "TECHNICAL DATA".

The maximum discharge and intake length (or linear reference length) can be calculated summing the length of the linear tube and that equivalent to each additional curve with respect to the first.

Subsequent addition of a curve is similar to adding a linear length of tube according to the indications below:

curve Ø80 at 90°= 1.5 m

curve Ø80 at 45°= 0.8 m

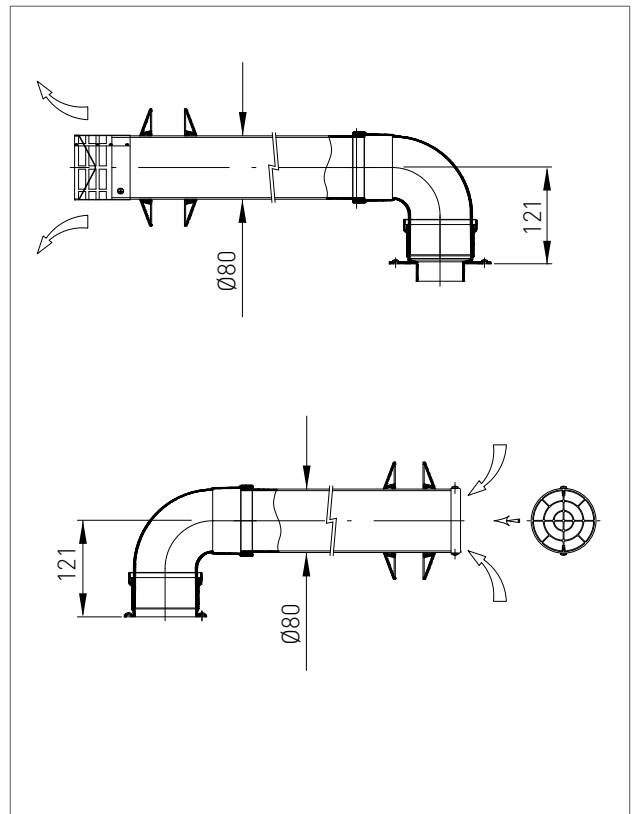
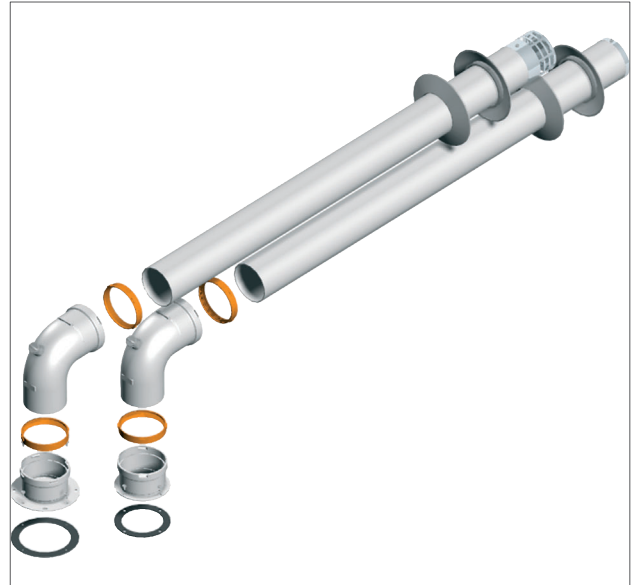

### KIT CK 50 - VERTICAL CO-AXIAL SYSTEM Ø80/125 INTERNAL POLYPROPYLENE DUCT.

It allows fumes discharge and air intake directly from roof.

Suitable only for condensing boilers.

It allows fuel gas discharge and air intake for combustion through co-axial ducts, the external one for air intake, the plastic internal one for fumes discharge.

PLEASE SEE THE MAXIMUM DISCHARGE LENGTH IN THE TABLE IN CHAPTER "TECHNICAL DATA".

The maximum discharge length (or linear reference length) can be calculated summing the length of the linear tube and that equivalent to each additional curve with respect to the first.

Subsequent addition of a curve is similar to adding a linear length of tube according to the indications below:

curve Ø80/125 at 90° = 0.8 m

curve Ø80/125 at 45° = 0.5 m

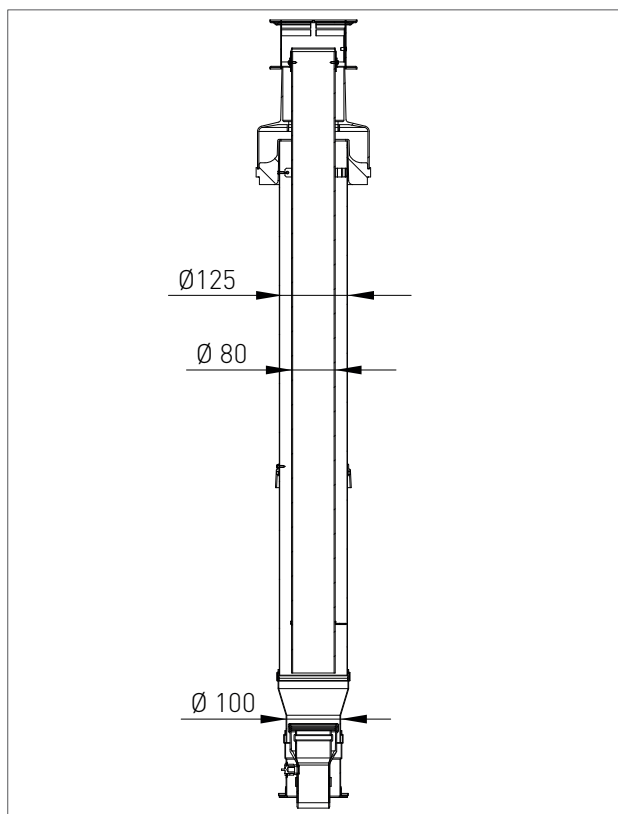
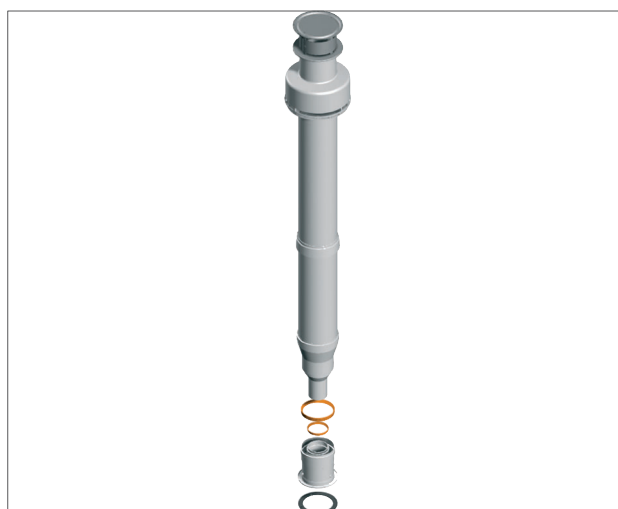



## 2. SUPPORT CENTER SECTION

All operations described below relative to first start-up, maintenance and replacement should be performed only by qualified personnel

### 2.1. FIRST START-UP

#### 2.1.1. PRELIMINARY OPERATIONS FOR FIRST START-UP

The first start-up operations consist in checking the correct installation, adjustment and operation of the device. Proceed as follows:

- › check the inner system sealing in accordance with the indications provided by standard and regulations in forced;
- › check if the gas used is suitable for the boiler;
- › check if the gas capacity and relative pressures comply with those on the plate;
- › check the intervention of the safety device in case of lack of gas;
- › make sure that the device supply voltage corresponds with that on the plate (230 V – 50 Hz) and that the wiring is correct;
- › make sure that the grounding system works properly;
- › make sure that the combustion air adduction and fumes and condensate discharge take place properly in compliance with the Local and National Laws and Standards in force;
- › make sure that the fumes discharge tube and its connection to the fume exhaust duct comply with the requirements of the Local and National Laws and Standards;
- › make sure that the heating system gate valves are open;
- › make sure that there is no intake of gaseous products within the system;
- › make sure that there are no flammable liquids or materials near the device;
- › open the boiler gas tap and make sure that there are no gas leaks upstream from the device (the burner gas connection must be checked while the machine is running);
- › in case of new installation of the gas supply network, the air inside the tubes may block the device at its first start-up. You might have to repeat the start-up procedure to purge all the air inside the tube.

### 2.1.2. BOILER COMMISSIONING



#### WARNING

*Make sure that the system is correctly filled.*

Proceed with boiler commissioning as follows:

Make sure the gas feed valve is switched off

- › Power the boiler.

THE START-UP SYSTEM WILL AUTOMATICALLY ACTIVATE THE SYSTEM AIR RELIEF CYCLE FUNCTION DISPLAYED ON SCREEN WITH CODE "F33" (ONLY AT FIRST START-UP WILL LAST FOR 5 MINUTES\*). When function "F33" is active, the pump is enabled and the burner start-up request is disabled. The boiler can work normally only after completing the operation.

- › Make sure the circulating pump is unblocked.
- › If it should be blocked, wait for the circulating pump to activate the automatic reset (lasting 3 min.)
- › If the circulating pump should be still blocked, activate the circulating pump automatic reset again (further 3 minutes), and switch off the power supply and switch it on again.
- › Open the gas tap.
- › Use the button  to select the desired operation mode. If the symbol is displayed fixed, it means that the function has been activated.
- › The burner will start as soon as the thermostat contact is closed ;
- › If the flame is missing, the board will repeat the start-up operations after post-ventilation (20 seconds).
- › You might have to repeat the start-up operation several times to release all the air inside the gas

tube. Before repeating the operation, wait at least 5 seconds from the last start-up attempt and unlock the boiler from "E01" error code by pressing the Reset  key.

(\*) The boiler performs the system venting cycle function (5 minutes) only during the first starting. After every water pressure reset the boiler will automatically perform a reduced system venting cycle (2 minutes). During this function the display shows F33 code. The correct boiler operation will be allowed only after this operation has been completed.

### 2.1.3. CO<sub>2</sub> VALUE CHECK AND CALIBRATION



#### WARNING

The CO<sub>2</sub> value should be checked with the casing assembled, while the gas valve should be adjusted with the casing open.

To check and calibrate the CO<sub>2</sub> value to minimum and maximum heating power proceed as follows:

#### FOR MINIMUM HEATING POWER

- › Enable chimney-sweep function (F07) by pressing 'F07' and 'R' (maximum operating time is 15 minutes), then press key '−' of the heating circuit to set minimum power for heating function, the display will show 'Lo'.
- › Insert the fumes analyser probe in the suitable 'PF' fumes inlet (fig. 1), then make sure that the CO<sub>2</sub> value complies with the requirements indicated in chapter "Technical data", otherwise unscrew the protection screw 'A' (fig. 2) and adjust using a 4 Allen wrench the screw '2' (fig. 2) of the Off-Set adjuster. To increase the CO<sub>2</sub> value, turn the screw clockwise and vice-versa if you want to decrease it. Once completed the adjustment, tighten the protection screw 'A' (fig. 2) on the Off-Set adjuster.

#### FOR MAXIMUM HEATING POWER

- › Press key '+ ' of the heating circuit to set maximum power for heating function, the display will show 'HI'.
- › Make sure that the CO<sub>2</sub> value complies with the indications in "Technical data", otherwise adjust using screw '1' (fig. 2) of the gas flow adjuster. To increase the CO<sub>2</sub> value, turn the screw anti-clockwise and vice-versa if you want to decrease it.
- › After each adjustment variation on screw '1' (fig. 2) of the gas flow adjuster you have to wait

for the boiler to stabilize itself to the set value (about 30 seconds).

- › Then press key '−' of the heating circuit and check that CO<sub>2</sub> value hasn't changed, in case it has changed, please repeat the setting as described previously.
- › To disable chimney-sweep function, press key 'R'.

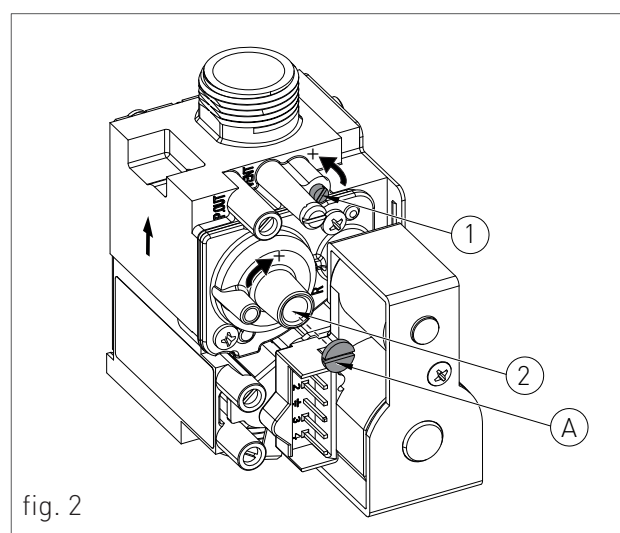
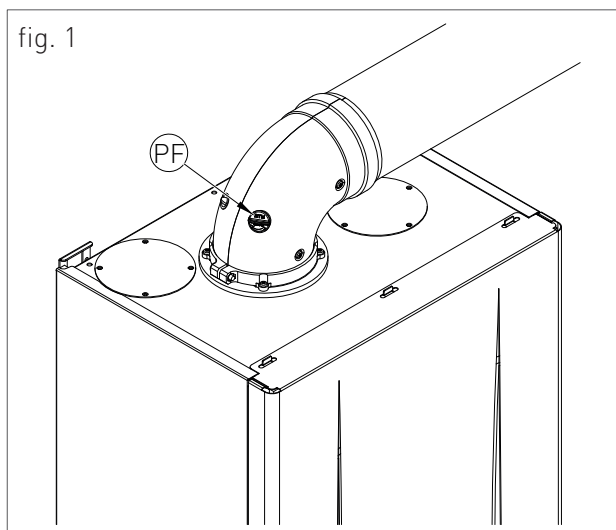

### 2.1.4. ACCESSING AND PROGRAMMING THE PARAMETERS

To access the parameters menu and adjust their values, follow the procedure below:

1. Press the "OFF" button to select the OFF mode.

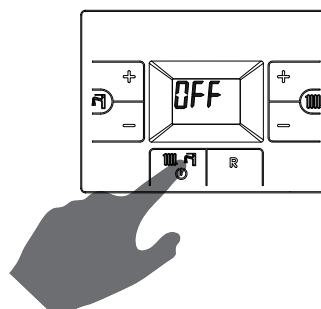

2. Press and hold both the 'R' and '-' heating circuit buttons and wait for 'P00' to appear on the display, then release the buttons.

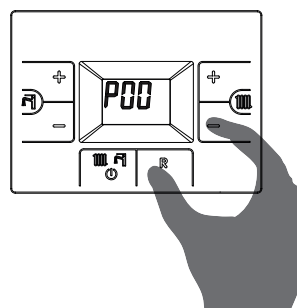

3. Use the keys '+' and '-' of the heating circuit to select the parameter to be edited.

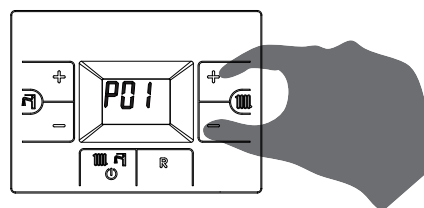

4. Keep the  button pressed until the parameter value is displayed.

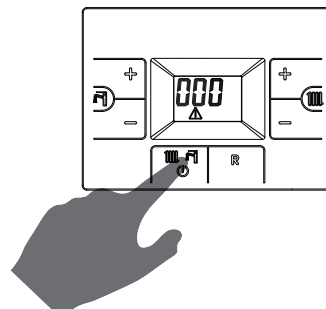

5. Use the  and  buttons of the heating circuit  to change the parameter value.

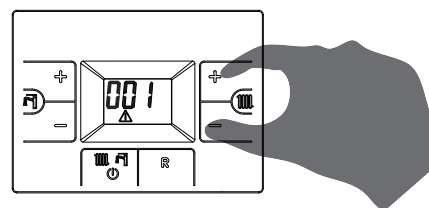

6. Keep the  button pressed until the parameter is displayed in order to confirm the modified value.

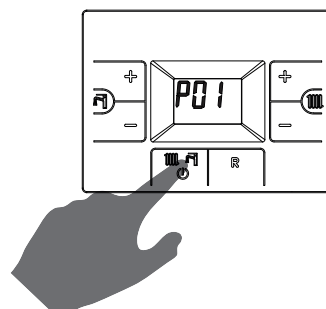

7. To quit the parameters menu, press the **(R)** button until 'OFF' is displayed.

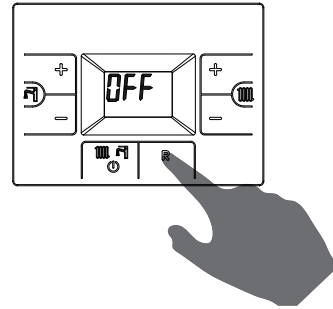

## 2. FIRST START-UP

### 2.1.5. MIAB3013 PARAMETERS TABLE

PARAMETER	DESCRIPTION	RANGE	FUNCTION
<b>P00</b>	<b>BOILER MODEL SELECTION</b>	00 - 04	00 = 24 kW 01 = 25 kW (HEAT.) / 28 kW (DOMESTIC) 02 = 34 kW 03 = 50 kW 04 = 24 kW - WITH HONEYWELL GAS VALVE
<b>P01</b>	<b>BOILER TYPE SELECTION</b>	00 - 03	00 = INSTANTANEOUS WITH INTEGRATED HEAT EXCHANGER FOR D.H.W. SIDE 01 = INSTANTANEOUS WITH D.H.W. PLATES EXCHANGER 02 = ACCUMULATION 03 = HEATING ONLY
<b>P02</b>	<b>GAS TYPE SELECTION</b> <b>ATTENTION:</b> READ THE INSTRUCTION IN CHAPTER 'GAS TRANSFORMATION' BEFORE CHANGING THIS PARAMETER.	00 - 01	00 = METHANE 01 = LPG
<b>P03</b>	<b>SETTING THE HEATING TEMPERATURE</b> IN CASE THE BOILER IS INSTALLED AS PART OF A LOW TEMPERATURE CIRCUIT, PLEASE INSTALL A SAFETY THERMOSTAT ON THE HEATING FLOW, WHICH CAN STOP THE BOILER ACTIVITY IN CASE OF HIGH HEATING FLOW TEMPERATURE. THE COMPANY ASSUMES NO LIABILITY FOR DAMAGE CAUSED TO PERSONS OR FOR FAILURE TO COMPLY WITH THESE INSTRUCTIONS.	00 - 01	00 = STANDARD (30-80 °C) (SET BY DEFAULT) 01 = REDUCED (25-45 °C) FOR FLOOR SYSTEMS

## 2. FIRST START-UP

PARAMETER	DESCRIPTION	RANGE	FUNCTION
<b>P04</b>	<b>HEATING RUN-UP</b> THROUGH THIS PARAMETER YOU CAN SET THE TIME, DURING START-UP PHASE, NECESSARY FOR THE BOILER TO REACH THE MAXIMUM SET POWER (ON THE HEATING SIDE).	00 - 04	00 = (DISABLED) 01 = 50 SECONDS 02 = 100 SECONDS 03 = 200 SECONDS (SET BY DEFAULT) 04 = 400 SECONDS
<b>P05</b>	<b>ANTI-WATER HAMMER SELECTION</b> ONCE THIS FUNCTION IS ENABLED, THE DHW CONTACT WILL BE DELAYED FOR A TIME EQUAL TO THE SET VALUE.	00 - 20	00 = DISABLED 01 - 20 = THE VALUE IS EXPRESSED IN SECONDS
<b>P06</b>	<b>DOMESTIC CIRCUIT PRESERVATION FUNCTION (ONLY FOR INSTANTANEOUS BOILERS)</b> THROUGH THIS PARAMETER YOU CAN PRESERVE THE CIRCULATOR THE DIVERTER VALVE IN DOMESTIC POSITION FOR A PERIOD OF TIME EQUAL TO THE POST-CIRCULATION (SEE PARAMETER P09), SO AS TO MAINTAIN THE SECONDARY EXCHANGER HOT.	00 - 01	00 = DISABLED (SET BY DEFAULT) 01 = ENABLED
<b>P07</b>	<b>HEATING TIMING</b> THROUGH THIS PARAMETER YOU CAN SET THE MINIMUM TIME FOR WHICH THE BURNER WILL BE TURNED OFF ONCE THE HEATING TEMPERATURE REACHED THE USER SET TEMPERATURE.	00 - 90	VALUE EXPRESSED IN MULTIPLES OF 5 SECONDS (PRE-SET AT 36 X 5 = 180 SECONDS)
<b>P08</b>	<b>POST-CIRCULATION HEATING TIMING</b> THROUGH THIS PARAMETER YOU CAN SET THE PUMP DURATION OF OPERATION DURING HEATING CYCLE, AFTER THE MAIN BURNER TURNS OFF DUE TO THE ENVIRONMENT THERMOSTAT.	00 - 90	VALUE EXPRESSED IN MULTIPLES OF 5 SECONDS (PRE-SET AT 36 X 5 = 180 SECONDS)
<b>P09</b>	<b>POST-CIRCULATION DOMESTIC / BOILER TIMING</b> THROUGH THIS PARAMETER YOU CAN SET THE PUMP OPERATION DURATION ON THE DOMESTIC CIRCUIT, AFTER THE TAP IS CLOSED.	00 - 90	VALUE EXPRESSED IN MULTIPLES OF 5 SECONDS (PRE-SET AT 24 X 5 = 120 SECONDS)

## 2. FIRST START-UP

PARAMETER	DESCRIPTION	RANGE	FUNCTION
<b>P10</b>	<b>DOMESTIC FAN MINIMUM SPEED ADJUSTMENT</b> THROUGH THIS PARAMETER YOU CAN SET THE FAN MINIMUM SPEED IN DOMESTIC PHASE, THAT CORRESPONDS TO THE MINIMUM BURNER POWER DURING A REQUEST TO OPERATE IN DOMESTIC MODE. THE VALUE IS PRE-SET BASED ON THE SET POWER (SEE PARAMETER P00) AND ON THE GAS TYPE (SEE PARAMETER P02).	SEE CHAPTER ' H E A T C A P A C I T Y D I A G R A M (KW) - ELECTRIC FAN FREQUENCY (HZ)	THE VALUE IS EXPRESSED IN HERTZ (1HZ = 30 RPM)
<b>P11</b>	<b>DOMESTIC FAN MAXIMUM SPEED ADJUSTMENT</b> THROUGH THIS PARAMETER YOU CAN SET THE FAN MAXIMUM SPEED IN DOMESTIC PHASE, THAT CORRESPONDS TO THE MAXIMUM BURNER POWER DURING A REQUEST TO OPERATE IN DOMESTIC MODE. THE VALUE IS PRE-SET BASED ON THE SET POWER (SEE PARAMETER P00) AND ON THE GAS TYPE (SEE PARAMETER P02).	SEE CHAPTER ' H E A T C A P A C I T Y D I A G R A M (KW) - ELECTRIC FAN FREQUENCY (HZ)	THE VALUE IS EXPRESSED IN HERTZ (1HZ = 30 RPM)
<b>P12</b>	<b>HEATING FAN MINIMUM SPEED ADJUSTMENT</b> THROUGH THIS PARAMETER YOU CAN SET THE FAN MINIMUM SPEED IN HEATING PHASE, THAT CORRESPONDS TO THE MINIMUM BURNER POWER DURING A REQUEST TO OPERATE IN HEATING MODE. THE VALUE IS PRE-SET BASED ON THE SET POWER (SEE PARAMETER P00) AND ON THE GAS TYPE (SEE PARAMETER P02).	SEE CHAPTER ' H E A T C A P A C I T Y D I A G R A M (KW) - ELECTRIC FAN FREQUENCY (HZ)	THE VALUE IS EXPRESSED IN HERTZ (1HZ = 30 RPM)
<b>P13</b>	<b>HEATING FAN MAXIMUM SPEED ADJUSTMENT</b> THROUGH THIS PARAMETER YOU CAN SET THE FAN MAXIMUM SPEED IN HEATING PHASE, THAT CORRESPONDS TO THE MAXIMUM BURNER POWER DURING A REQUEST TO OPERATE IN HEATING MODE. THE VALUE IS PRE-SET BASED ON THE SET POWER (SEE PARAMETER P00) AND ON THE GAS TYPE (SEE PARAMETER P02).	SEE CHAPTER ' H E A T C A P A C I T Y D I A G R A M (KW) - ELECTRIC FAN FREQUENCY (HZ)	THE VALUE IS EXPRESSED IN HERTZ (1HZ = 30 RPM)

## 2. FIRST START-UP

PARAMETER	DESCRIPTION	RANGE	FUNCTION
<b>P14</b>	<p><b>STARTING STEP ADJUSTMENT</b></p> <p>THROUGH THIS PARAMETER YOU CAN SET THE FAN SPEED DURING START-UP. THE VALUE IS PRE-SET BASED ON THE SET POWER (SEE PARAMETER P00) AND ON THE GAS TYPE (SEE PARAMETER P02).</p>	<p>SEE CHAPTER ' H E A T C A P A C I T Y D I A G R A M (KW) - ELECTRIC FAN FREQUENCY (HZ)</p>	<p>THE VALUE IS EXPRESSED IN HERTZ (1HZ = 30 RPM)</p>
<b>P15</b>	<p><b>ANTI-LEGIONELLA FUNCTION (FOR STORAGE BOILERS ONLY)</b></p> <p>THROUGH THIS PARAMETER YOU CAN ACTIVATE/DEACTIVATE THE "ANTILEGIONELLA" HEAT TREATMENT OF THE STORAGE TANK AND SET THE DAYS AFTER THAT THIS FUNCTION CAN BE AUTOMATICALLY ACTIVATED. THE DEFAULT VALUE IS 7 DAYS. STARTING FROM THAT MOMENT THE WATER TEMPERATURE INSIDE THE STORAGE IS HEATED BEYOND 60 °C THUS GENERATING A BURNING HAZARD. KEEP UNDER CONTROL SUCH DOMESTIC HOT WATER TREATMENT (AND INFORM THE USERS) TO AVOID UNFORSEEABLE DAMAGES TO PERSONS, ANIMALS AND PROPERTY. A THERMOSTATIC VALVE SHOULD BE INSTALLED AT THE DOMESTIC HOT WATER OUTLET TO AVOID ANY BURNS.</p>	<p>00 - 15</p>	<p>00 = DISABLED</p> <p>01-15 = DAYS AFTER THAT THE FUNCTION IS AUTOMATICALLY ACTIVATED</p>

## 2. FIRST START-UP

PARAMETER	DESCRIPTION	RANGE	FUNCTION
<b>P16</b>	<p><b>CLIMATE COMPENSATION CURVE</b> <b>(ONLY WITH EXTERNAL PROBE CONNECTED)</b></p> <p>YOU CAN CONNECT AN EXTERNAL TEMPERATURE PROBE (SEE CHAPTER 'ELECTRICAL CONNECTIONS') THAT AUTOMATICALLY CHANGES THE DELIVERY TEMPERATURE BASED ON THE EXTERNAL MEASURED TEMPERATURE. THE NATURE OF THE CORRECTION DEPENDS ON THE THERMO-ADJUSTMENT VALUE KD SET (SEE CHART).</p> <p>THE SELECTION OF THE CURVE IS DETERMINED BY THE MAXIMUM DELIVERY TEMPERATURE <math>T_m</math> AND THE MINIMUM EXTERNAL TEMPERATURE <math>T_e</math> TAKING INTO ACCOUNT THE HOUSE INSULATION DEGREE.</p> <p>THE VALUES OF THE DELIVERY TEMPERATURES <math>T_m</math>, REFER TO STANDARD SYSTEMS 30-80 °C OR FLOOR SYSTEMS 25-45 °C. THE SYSTEM TYPE CAN BE SET FROM PARAMETER P03.</p>	00 - 30	(SET BY DEFAULT AT 25) THE NUMBERING OF THE VALUE CORRESPONDS TO 'KD' CURVES ON THE CHART (SEE CHART BELOW).

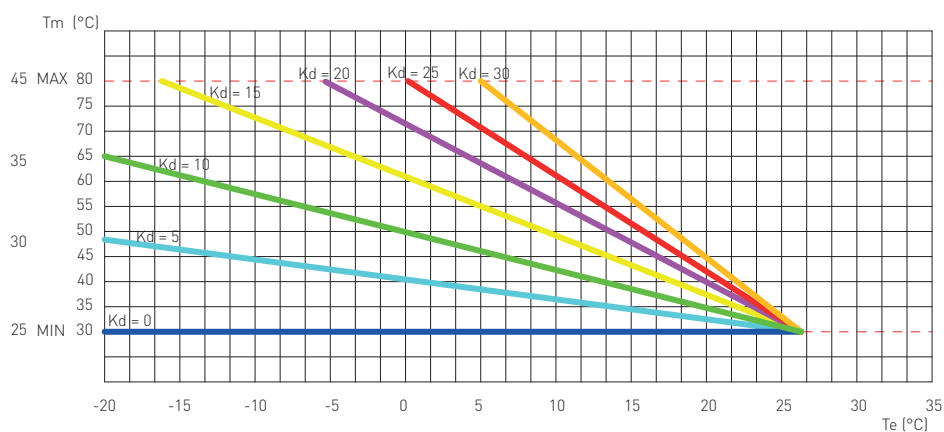

<b>P17</b>	<p><b>SET POINT <math>\Delta T</math> DELIVERY-RETURN</b> <b>(ONLY WITH MODULATING PUMP AND RETURN PROBE CONNECTED)</b></p> <p>THROUGH THIS PARAMETER YOU CAN SET THE TEMPERATURE DIFFERENCE BETWEEN DELIVERY AND RETURN.</p>	00 - 40	00 = DISABLED  THE VALUE IS EXPRESSED IN °C
------------	---	---------	---

## 2. FIRST START-UP

PARAMETER	DESCRIPTION	RANGE	FUNCTION
P18	<p><b>MODULATING PUMP MINIMUM SPEED</b> <i>(ONLY WITH MODULATING PUMP AND RETURN PROBE CONNECTED)</i></p> <p>THROUGH THIS PARAMETER YOU CAN SET THE MINIMUM SPEED VALUE OF THE MODULATING PUMP DURING A REQUEST TO OPERATE IN HEATING MODE.</p>	50 - 70	THE VALUE IS EXPRESSED IN PERCENTAGE
P19	<p><b>MODULATING PUMP MAXIMUM SPEED</b> <i>(ONLY WITH MODULATING PUMP AND RETURN PROBE CONNECTED)</i></p> <p>THROUGH THIS PARAMETER YOU CAN SET THE MAXIMUM SPEED VALUE OF THE MODULATING PUMP DURING A REQUEST TO OPERATE IN HEATING MODE.</p>	70 - 100	THE VALUE IS EXPRESSED IN PERCENTAGE
P20	<p><b>CONTROL PERIOD <math>\Delta T</math> DELIVERY-RETURN</b> <i>(ONLY WITH MODULATING PUMP AND RETURN PROBE CONNECTED)</i></p> <p>THROUGH THIS PARAMETER YOU CAN SET THE RESPONSE TIME TO THE PUMP MODULATION.</p>	20 - 100	THE VALUE IS EXPRESSED IN SECONDS
P21	<p><b>D.H.W STORAGE TANK TEMPERATURE SETPOINT</b> <i>(FOR STORAGE BOILERS ONLY)</i></p> <p>THROUGH THIS PARAMETER YOU CAN SET THE PRIORITY STARTING VALUE OF THE STORAGE TANK, COMPARED TO THE USER ADJUSTABLE D.H.W SETPOINT.</p>	03 - 09	THE VALUE IS EXPRESSED IN °C (PRE-SET AT 9°C)
P22	<b>TYPE OF VISUALIZATION</b>	00 - 01	<p>00 = HEATING CIRCUIT TEMPERATURE ONLY</p> <p>01 = TEMPERATURE ACCORDING TO THE TYPE OF OPERATION (D.H.W. OR HEATING)</p>

## 2. FIRST START-UP

PARAMETER	DESCRIPTION	RANGE	FUNCTION
<b>P23</b>	<p><b>DISABLEMENT OF DOMESTIC HOT WATER LINE BY MEANS OF SWITCH (ONLY FOR FAST BOILERS)</b></p> <p>BY ENABLING THIS PARAMETER IN THE PRESENCE OF A CONNECTION (FOR EXAMPLE A BOILER CLOCK OR A TEMPERATURE THERMOSTAT) ON BOILER CLOCK SWITCH ON THE BOARD, THE REQUEST FOR BURNER IGNITION ON THE DOMESTIC HOT WATER LINE WILL BE DISABLED UPON BOILER CLOCK SWITCH CLOSURE.</p> <p><b>EXAMPLE 1:</b> WITH THE BOILER CLOCK SWITCH OPEN, UPON THE REQUEST FOR DOMESTIC HOT WATER, THE FLOW SWITCH AND THE BOILER WILL TURN ON.</p> <p><b>EXAMPLE 2:</b> WITH THE BOILER CLOCK SWITCH CLOSE, UPON THE REQUEST FOR DOMESTIC HOT WATER, THE FLOW SWITCH AND THE BOILER WILL NOT TURN ON.</p>	0 - 1	<p>0 = DISABLED (SET BY DEFAULT)</p> <hr/> <p>1 = ENABLED</p>
<b>P24</b>	<p><b>ACTIVATION OF THE AUXILIARY RELAY ON THE "SVZ" P.C.B. (SEE CHAPTER: OPTIONAL ELECTRICAL CONNECTIONS)</b></p> <p>THROUGH THIS PARAMETER IT IS POSSIBLE TO MANAGE THE TYPE OF FUNCTIONING OF THE AUXILIARY RELAY ON THE "SVZ" P.C.B. (CLAMP M4, PIN 5-6).</p> <p>WHEN THE VALUE OF THE PARAMETER IS SET TO '3', THE ENABLING OR DISABLING OF THE AUXILIARY RELAY IS GIVEN BY THE "TP" CONTACT (SEE CHAPTER: OPTIONAL ELECTRICAL CONNECTIONS). WHEN THE "TP" CONTACT IS OPEN, THE RELAY STAYS ENERGIZED (WORKING RECIRCULATION PUMP) WHILE WHEN THE "TP" CONTACT IS CLOSED, THE RELAY IS DE-ENERGIZED (NOT WORKING RECIRCULATION PUMP).</p>	0 - 4	<p>0 = DISABLED (SET BY DEFAULT)</p> <p>1 = HEATING CIRCUIT BOOSTER PUMP</p> <p>2 = D.H.W. BOOSTER PUMP</p> <p>3 = RECIRCULATION PUMP</p> <p>4 = REMOTE LED FOR SIGNALLING BOILER BLOCK</p> <p>(SEE CHAPTER: OPTIONAL ELECTRICAL CONNECTIONS)</p>

2.1.6. ELECTRIC FAN FREQUENCY/HEAT CAPACITY DIAGRAM

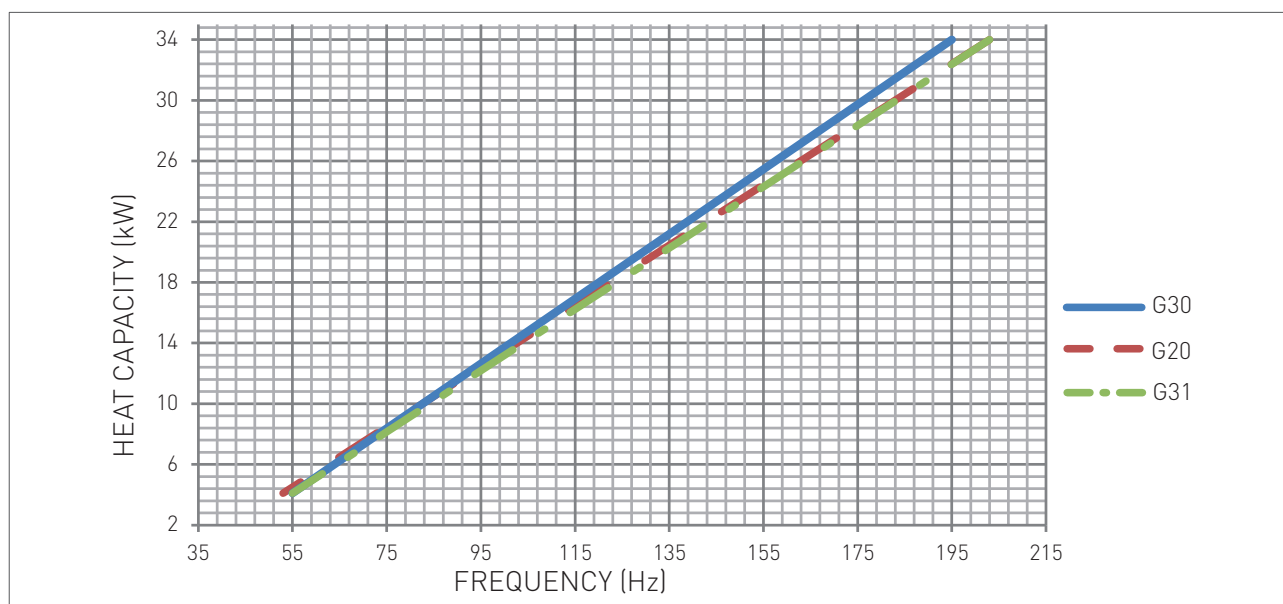

GAS TYPE	MINIMUM FREQUENCY	MAXIMUM FREQUENCY	STARTING STEP ADJUSTMENT
G20	Hz 53	203	110
G30	Hz 55	195	130
G31	Hz 55	203	130

## 2.2. MAINTENANCE

## 2.2.7. GENERAL MAINTENANCE WARNINGS

**DANGER**

*Before each components cleaning or replacement operation, ALWAYS cut off the POWER, WATER and GAS supply of the boiler.*

**WARNING**

*To ensure greater life span and proper operation of the device, during the maintenance operations use only original spare parts.*

**ATTENTION**

*To ensure the efficiency and safety of the device, the maintenance operations must be realized on an annual basis. The operations described below, are essential to the validity of the standard Flexiheat warranty and must be performed by professionally qualified personnel*

Please perform the following operations once a year:

- › Check that the system's water PH is between 6.5 and 8.5;
- › check the pre-load pressure of the expansion vessel;
- › check the sealing of the water components, and replace if necessary the gaskets;
- › check that the wiring is performed in compliance with the requirements in the boiler instruction manual;
- › check the wiring inside the control panel;
- › remove and clean the burner from oxidation;
- › check the integrity and the position of the sealed chamber sealing gasket;
- › check the primary exchanger, if necessary, clean it;
- › check the operation of the gas light up and safety systems. If necessary, remove and clean the flame detection and light up electrodes from incrustations paying attention to respect the distances with respect to the burner;
- › check the sealing of the gas components, and replace if necessary the gaskets;
- › visually check the flame and the condition of the combustion chamber;
- › if necessary make sure that the combustion is suitably adjusted and if required proceed as indicated in section "CO2 VALUE CHECK AND CALIBRATION";
- › periodically check the integrity of the fume exhaustion system for safety and proper operation;
- › make sure that the permanent ventilation outlets are present, correctly sized and functioning, based on the installed devices. Respect the requirements provided by Local and National legislation;
- › check the heating circuit safety systems: limit temperature safety thermostat; limit pressure safety;
- › check the proper operation of the condensate draining system, including the devices outside the boiler such as condensate collection devices installed along the path of the fume exhaust duct or neutralization devices for acid condensate. Check that the liquid flow is not obstructed and that there are no combustion gas refluxes inside the internal system;
- › check the flow and temperature of domestic hot water.

## 2.2.8. TECHNICAL DATA

Model		R2C 34
Maximum nominal heat capacity in heating circuit	kW	34
Maximum nominal heat capacity in domestic circuit	kW	34
Minimum nominal heat capacity in heating circuit	kW	4,1
Minimum nominal heat capacity in domestic circuit	kW	4,1
Useful thermal power - 60/80°C	kW	33,35
Minimum useful thermal power - 60/80°C	kW	3,94
Useful thermal power - 30/50°C	kW	36,19
Performance at 100% Pn - 60/80°C	%	98,08
Performance at 30% Pm - return 47°C	%	102,14
Performance at 30% Pm - return 30°C	%	108,6
Performance at 100% Pn - 30/50°C	%	106,43
Maximum combustion Performance	%	97,6
Fumes temperature at nominal heat capacity	°C	69,4
Fumes temperature at minimum heat capacity	°C	61,3
CO2 at nominal heat capacity - G20	%	9,45 - 9,25
CO2 at minimum heat capacity - G20	%	9,05 - 8,85
CO2 at nominal heat capacity - G30	%	11,4 - 11,2
CO2 at minimum heat capacity - G30	%	10,75 - 10,55
CO2 at nominal heat capacity - G31	%	10,55 - 10,35
CO2 at minimum heat capacity - G31	%	9,9 - 9,7
CO at nominal heat capacity	ppm	75
Fumes mass at nominal heat capacity	g/s	14,96
Fumes mass at minimum heat capacity	g/s	1,88
NOx class	class	6
Weighted Nox (0% O2) mg/kWh	mg/kWh	55
<b>Heating circuit</b>		
Adjustable heating temperature	°C	30-80 / 25-45
Maximum operating temperature for heating circuit	°C	80
Maximum operating pressure for heating circuit	bar	3
Minimum operating pressure for heating circuit	bar	0,3
Capacity of the system expansion vessel	litres	8
<b>Domestic circuit</b>		
Adjustable domestic temperature	°C	35-60
Maximum pressure for domestic circuit	bar	6
Minimum pressure for domestic circuit	bar	0,5
Specific capacity in continuous service - Δt 30°C	litres/min	16
<b>Dimensional characteristics</b>		
Width	mm	410
Depth	mm	350
Height	mm	642
Gross weight	Kg	44
<b>Water connections</b>		
Flow	∅	3/4"
Cold water	∅	1/2"

## 2. MAINTENANCE

Hot water	Ø	1/2"
Gas	Ø	3/4"
Return	Ø	3/4"

### Fume exhaust fittings

Maximum electric fan pressure available	Pa	91
Minimum electric fan pressure available	Pa	5,8
Max discharge length Ø60/100 - Hor Co-ax	m	2
Max discharge length Ø80/125 - Hor Co-ax	m	10
Max discharge length Ø50/50 - Hor Split	m	3
Max discharge length Ø60/60 - Hor Split	m	18
Max discharge length Ø80/80 - Hor Split	m	60
Max discharge length Ø50 - Hor duct	m	3
Max discharge length Ø60 - Hor duct	m	14
Max discharge length Ø80 - Hor duct	m	35
Max discharge length Ø60/100 - Vert Co-ax	m	2
Max discharge length Ø80/125 - Vert Co-ax	m	10
Max discharge length Ø50/50 - Vert Split	m	3
Max discharge length Ø60/60 - Vert Split	m	18
Max discharge length Ø80/80 - Vert Split	m	60
Max discharge length Ø50 - Vert duct	m	3
Max discharge length Ø60 - Vert duct	m	14
Max discharge length Ø80 - Vert duct	m	35

### Electrical specifications

Voltage-frequency	V/Hz	230/50
Max Absorbed Power	W	78
Insulation rate	IP	X5D

### Gas supply

Nominal supply pressure - G20	mbar	20
Heating Max. fan speed - G20	Hz	203
D.H.W Max fan speed - G20	Hz	203
Heating Min. fan speed - G20	Hz	53
D.H.W Min. fan speed - G20	Hz	53
Fuel consumption - G20	m <sup>3</sup> /h	3,60
Nominal Supply pressure - G30	mbar	28-30
Heating Max. fan speed - G30	Hz	195
D.H.W Max fan speed - G30	Hz	195
Heating Min. fan speed - G30	Hz	55
D.H.W Min. fan speed - G30	Hz	55
Fuel consumption - G30	kg/h	2,68
Nominal Supply pressure - G31	mbar	37
Heating Max. fan speed - G31	Hz	203
D.H.W Max fan speed - G31	Hz	203
Heating Min. fan speed - G31	Hz	55
D.H.W Min. fan speed - G31	Hz	55
Fuel consumption - G31	kg/h	2,64

## 2.2.9. TECHNICAL ASSEMBLY

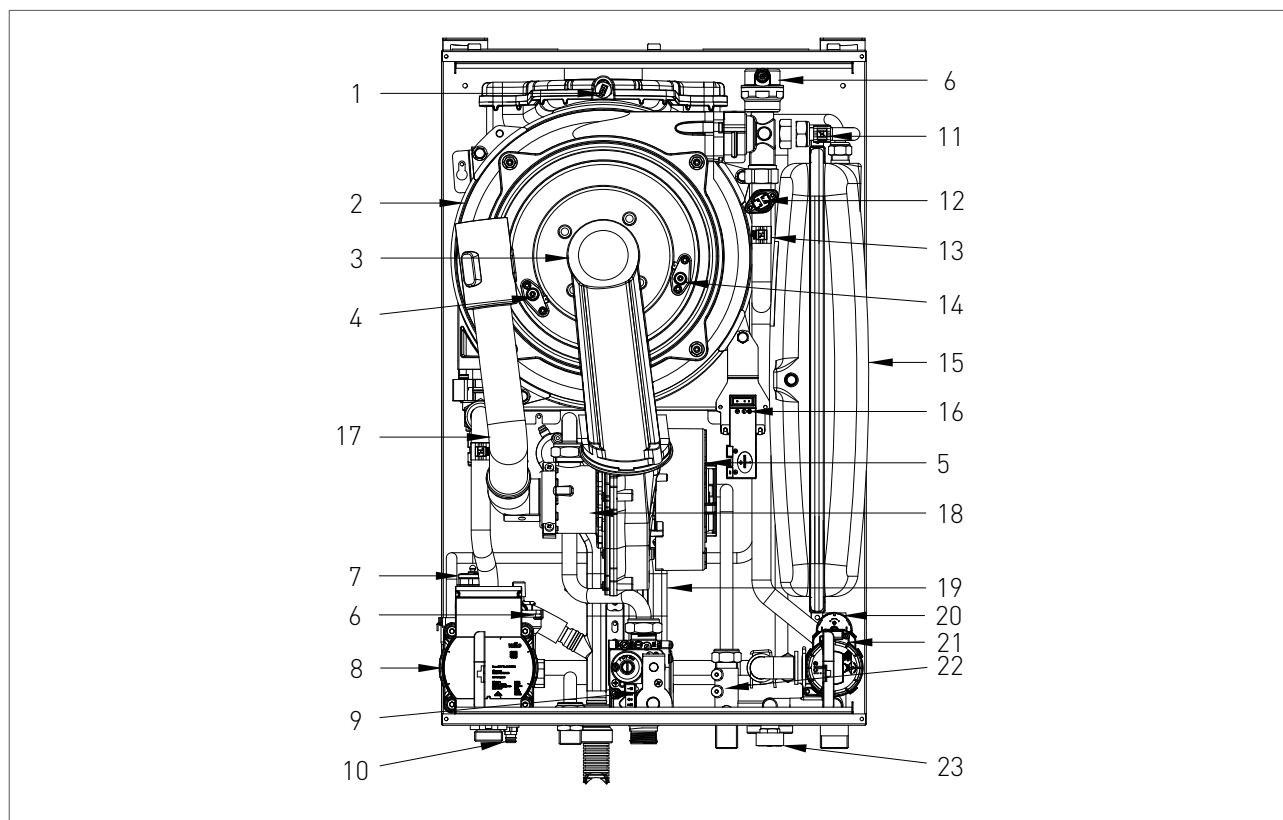
**KEY**

1. FUMES SAFETY THERMOFUSE
2. INTEGRATED HEAT EXCHANGER
3. BURNER UNIT
4. DETECTION ELECTRODE
5. ELECTRIC FAN
6. AIR RELIEF VALVE
7. SAFETY VALVE 3 bar
8. CIRCULATOR
9. GAS VALVE
10. SYSTEM DRAINING TAP
11. DOMESTIC CIRCUIT PROBE
12. SAFETY THERMOSTAT
13. HEATING PROBE
14. LIGHT UP ELECTRODE
15. EXPANSION TANK
16. START-UP TRANSFORMER
17. AIR SUCTION TUBE
18. PROPORTIONAL VENTURI
19. CONDENSATE COLLECTION SIPHON
20. WATER PRESSURE SWITCH
21. DIVERTER VALVE
22. FLOW SWITCH

23. SYSTEM FILLING TAP

2.2.10. HYDRAULIC BOARD

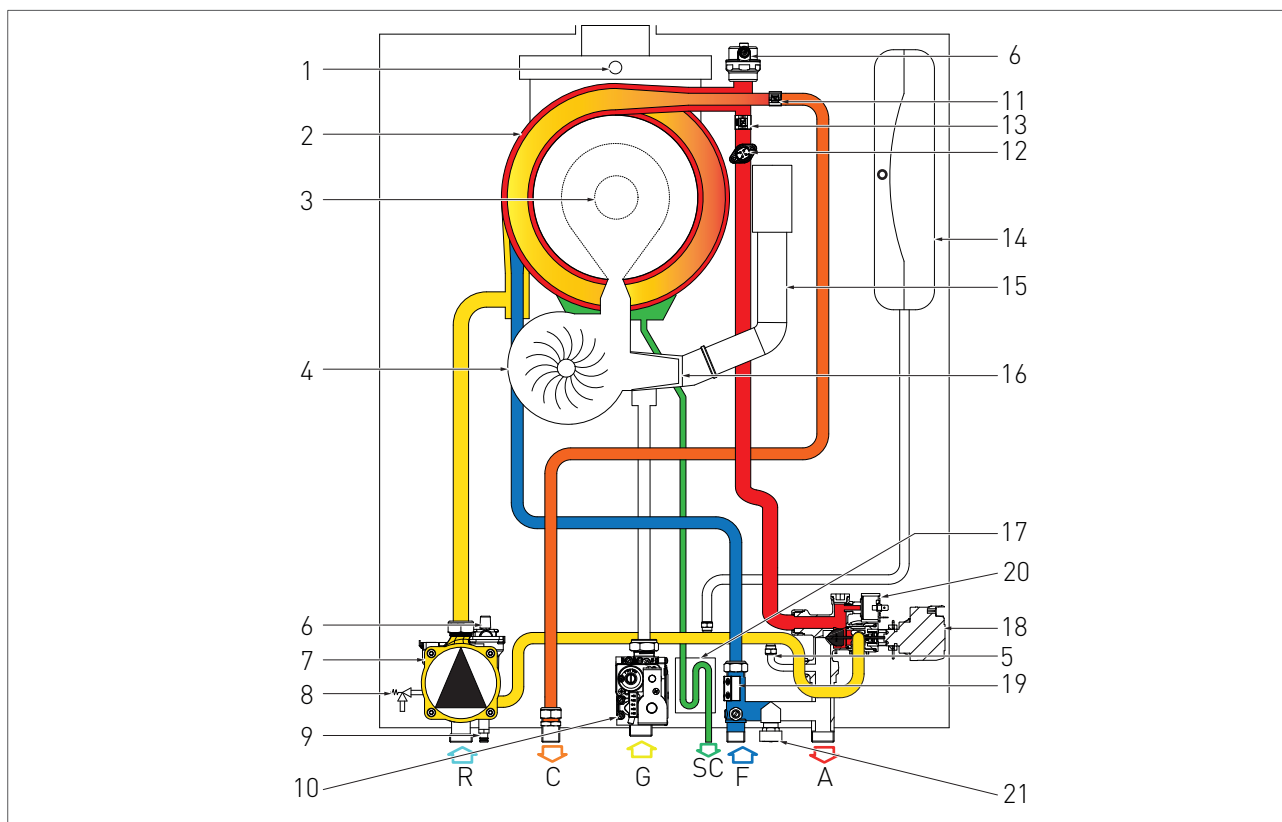

**KEY**

- |                              |                                  |
|------------------------------|----------------------------------|
| R. HEATING RETURN            | 16. PROPORTIONAL VENTURI         |
| C. DOMESTIC HOT WATER OUTLET | 17. CONDENSATE COLLECTION SIPHON |
| G. GAS INLET                 | 18. DIVERTER VALVE               |
| SC. CONDENSATE DRAIN         | 19. FLOW SWITCH                  |
| F. COLD WATER INLET          | 20. WATER PRESSURE SWITCH        |
| A. HEATING FORWARD           | 21. SYSTEM FILLING TAP           |
- 
1. FUMES SAFETY THERMOFUSE
  2. INTEGRATED HEAT EXCHANGER
  3. BURNER UNIT
  4. ELECTRIC FAN
  5. BY-PASS
  6. AIR RELIEF VALVE
  7. CIRCULATOR
  8. SAFETY VALVE 3 bar
  9. SYSTEM DRAINING TAP
  10. GAS VALVE
  11. DOMESTIC CIRCUIT PROBE
  12. SAFETY THERMOSTAT
  13. HEATING PROBE
  14. EXPANSION TANK
  15. AIR SUCTION TUBE

2.2.11. WIRING DIAGRAM

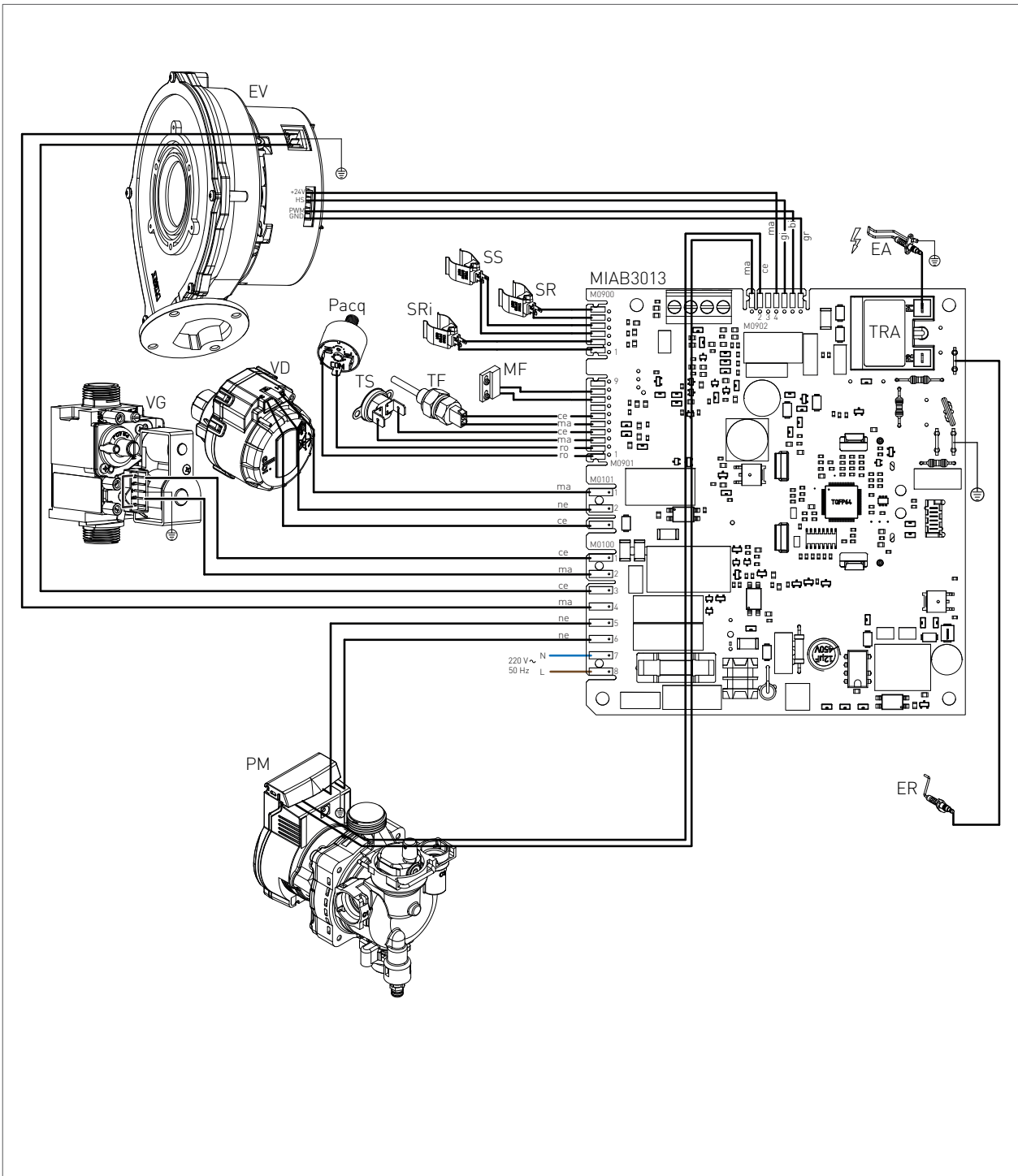

ER: DETECTION ELECTRODE  
 EA: START-UP ELECTRODE  
 PM: MODULATING PUMP  
 VG: GAS VALVE  
 TRA: START-UP TRANSFORMER  
 TF: FUMES THERMOFUSE (102°C)  
 VD: DIVERTER VALVE

TS: SAFETY THERMOSTAT  
 PACQ: WATER PRESSURE SWITCH  
 MF: MICRO-FLOW SWITCH  
 SR: HEATING PROBE  
 SS: DOMESTIC CIRCUIT PROBE  
 EV: ELECTRIC FAN  
 SRI: RETURN SENSOR

L: LINE  
 N: NEUTRAL  
 NE: BLACK

CE: BLUE  
 MA: BROWN  
 AR: ORANGE  
 GI: YELLOW  
 BI: WHITE  
 GR: GREY

### 2.2.12. ACCESSING THE BOILER

For the majority of the control and maintenance operations you have to remove one or more panels of the casing.

The side panels can be removed only after removing the front panel.

To intervene on the front of the boiler proceed as follows:

- › remove the fastening screws (1 - fig.1) placed on the lower edge of the front panel;
- › grab the front panel from the bottom and remove it pulling it to yourself and then upwards (see fig. 1).

To intervene on the side panels of the boiler proceed as follows:

- › remove the fastening screws (2 - fig.1) placed on the front edge of the side panel;
- › grab the bottom of the panel and remove it by moving it sideways and then pulling it upwards (see fig. 1).

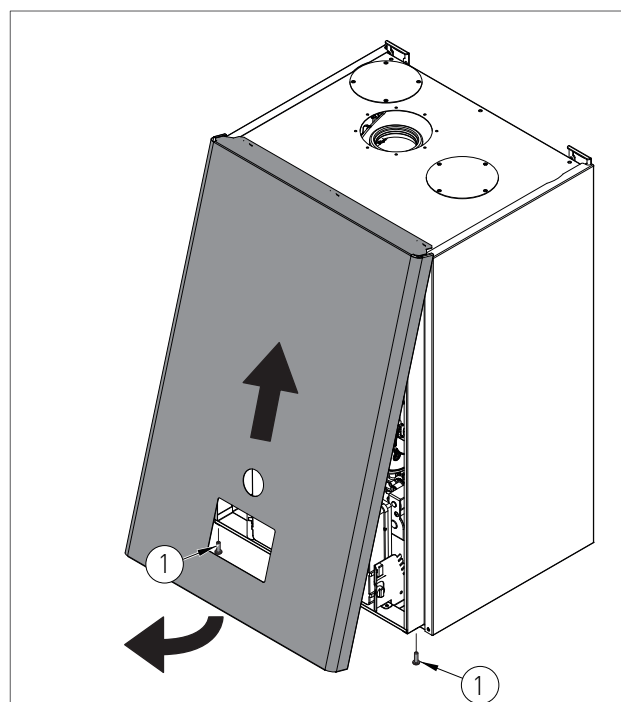
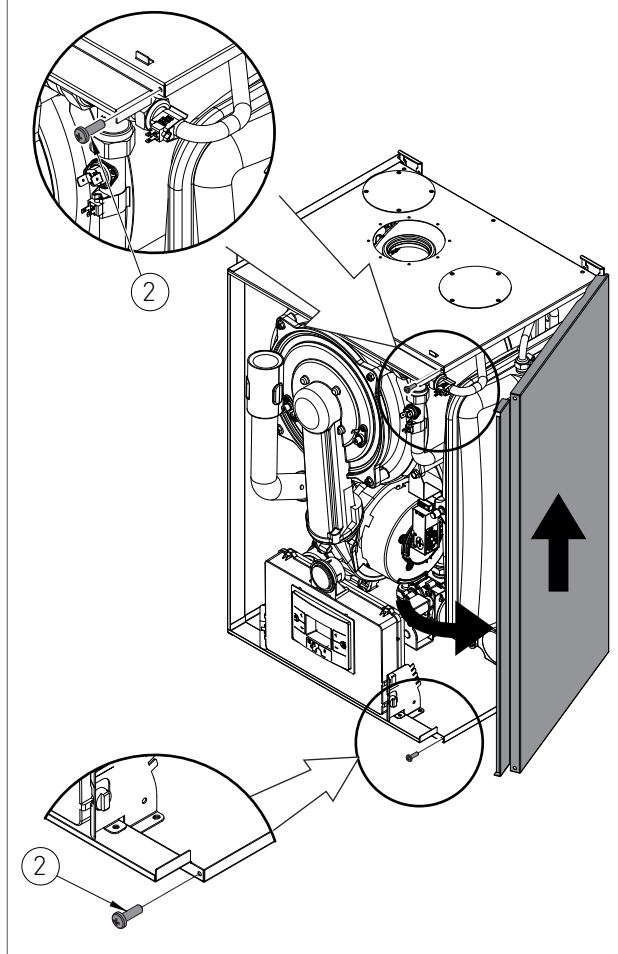

fig. 1



### 2.2.13. ACCESSING THE ELECTRONIC BOARD

In order to intervene on the wirings of the control panel, please proceed as follows:



#### **DANGER**

*Cut off the voltage from the main switch.*

- > Grab at the same time the support brackets of the control panel (fig. 1) loosening them and turn the panel downwards;
- > unscrew the two fastening screws 1 - fig. 1;
- > disengage the four hooks '2' - fig. 1;
- > remove the crankcase pulling it upwards.

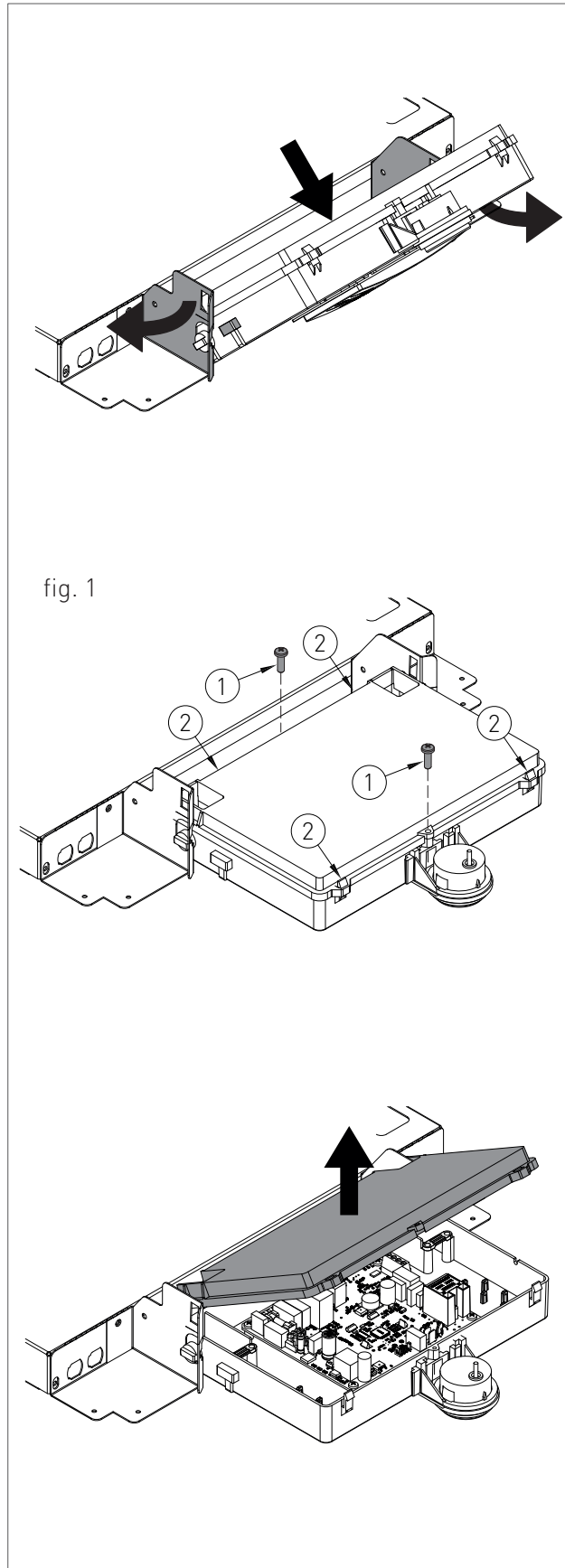

### 2.2.14. SYSTEM EMPTYING

#### HEATING SYSTEM EMPTYING

Whenever you need to empty the system, proceed as follows:

- › switch the boiler to “WINTER” mode and activate it;
- › turn off the main power supply switch;
- › wait for the boiler to cool down;
- › connect a flexible tube to the system emptying outlet and connect the other end of the tube to a suitable discharge;
- › turn the discharge tap of the system 'RS' (fig. 1);
- › open the relief valves of the radiators starting from the one at the top and continuing downwards;
- › after draining out all water, close the relief valves of the radiators and the emptying tap.

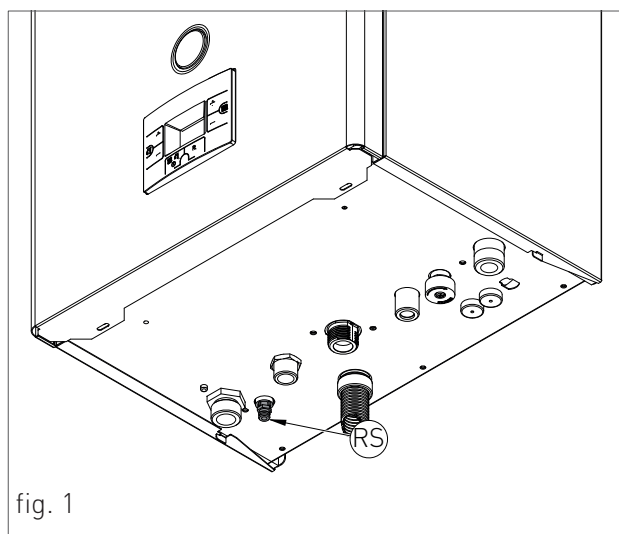

#### EMPTYING THE DOMESTIC SYSTEM

If there is freezing risk, you have to empty the domestic system as follows:

- › close the main supply tap of the water supply network;
- › open all cold and hot water taps;
- › after completing all operations, close the discharge tap and all previously opened water taps.

2.2.15. FAULT SIGNALLING CODES

CODE	FAULT	POSSIBLE CAUSE	SOLUTION	RESET	
E01	<b>FLAME BLOCK</b>	<b>NO FLAME LIGHT UP</b>		MANUAL RESET (PRESS THE RESET Ⓡ KEY).	
		GAS MISSING;	CHECK THE ADDUCTION NETWORK;		
		MASS OR BROKEN START-UP ELECTRODE;	REPLACE IT;		
		GAS VALVE BROKEN;	REPLACE IT;		
		SLOW LIGHT UP TOO LOW ADJUSTMENT;	ADJUST MINIMUM OR SLOW LIGHT UP;		
		VALVE INFEEED PRESSURE TOO HIGH (ONLY FOR GPL BOILERS).	CHECK THE MAXIMUM ADJUSTMENT PRESSURE		
		<b>WITH FLAME LIGHT UP</b>			
		NEUTRAL AND PHASE INVERTED POWER SUPPLY;	PROPERLY CONNECT THE POWER SUPPLY;		
		DETECTION ELECTRODE BROKEN;	REPLACE IT;		
		DETECTION ELECTRODE CABLE DISCONNECTED.	CHECK THE WIRING.		
ELECTRICAL CURRENT PHASE-PHASE	IF THE TENSION MEASURES BETWEEN NEUTRAL AND GROUND IS ALMOST EQUAL TO THE ONE MEASURED BETWEEN PHASE AND GROUND, YOU HAVE TO INSTALL A PHASE-PHASE TRANSFORMER KIT (COD. 88021LA)				
E02	<b>SAFETY THERMOSTAT (95°C)</b>	THERMOSTAT CABLE DISCONNECTED;	CHECK THE WIRING:	AUTOMATIC.	
		BROKEN THERMOSTAT.	REPLACE IT.		

## 2. MAINTENANCE







CODE	FAULT	POSSIBLE CAUSE	SOLUTION	RESET
E03	<b>FUMES SAFETY</b> <b>THERMOFUSE (102°C)</b>	THERMOFUSE BROKEN;	REPLACE IT;	MANUAL RESET (PRESS THE RESET Ⓡ KEY).
		THERMOFUSE CABLE DISCONNECTED.	CHECK THE WIRING.	
E04	<b>WATER MISSING IN THE SYSTEM</b>	INSUFFICIENT WATER PRESSURE INSIDE THE SYSTEM (LOWER THAN 0.3 BAR);	LOAD THE SYSTEM;	AUTOMATIC.
		WATER PRESSURE SWITCH CABLE DISCONNECTED;	CHECK THE WIRING;	
		WATER PRESSURE SWITCH BROKEN.	REPLACE IT.	
E05	<b>HEATING PROBE</b>	BROKEN OR INCORRECTLY CALIBRATED PROBE (RESISTANCE VALUE 10 KOHM AT 25 °C NTC);	REPLACE IT;	AUTOMATIC.
		DISCONNECTED OR WET PROBE CONNECTOR.	CHECK THE WIRING.	
E06	<b>DOMESTIC PROBE</b>	BROKEN OR INCORRECTLY CALIBRATED PROBE (RESISTANCE VALUE 10 KOHM AT 25 °C NTC);	REPLACE IT;	AUTOMATIC.
		DISCONNECTED OR WET PROBE CONNECTOR.	CHECK THE WIRING.	
E15	<b>RETURN PROBE</b>	BROKEN OR INCORRECTLY CALIBRATED PROBE (RESISTANCE VALUE 10 KOHM AT 25 °C NTC);	REPLACE IT;	AUTOMATIC.
		DISCONNECTED OR WET PROBE CONNECTOR.	CHECK THE WIRING.	

## 2. MAINTENANCE

CODE	FAULT	POSSIBLE CAUSE	SOLUTION	RESET
E16	<b>ELECTRIC FAN</b>	ELECTRIC FAN BOARD BROKEN;	REPLACE IT;	AUTOMATIC.
		ELECTRIC FAN BROKEN;	REPLACE IT;	
		FAULTY POWER SUPPLY CABLE.	REPLACE IT.	
E22	<b>P A R A M E T E R S PROGRAMMING REQUEST</b>	MICRO=PROCESSOR MEMORY LOSS.	PARAMETERS REPROGRAMMING.	MANUAL RESET (CUT OFF THE TENSION).
E31	<b>REMOTE CONTROLLER INCOMPATIBLE</b>	INDICATES THAT THE REMOTE CONTROLLER CONNECTED TO THE BOILER IS NOT COMPATIBLE WITH THE CIRCUIT BOARD	REPLACE IT WITH A COMPATIBLE MODEL.	AUTOMATIC.
E98	<b>SUPPLY VOLTAGE</b>	SUPPLY VOLTAGE OFF THE OPERATION RANGE ( $\leq 160$ VOLTS).	CHECK THE POWER SUPPLY NETWORK (THE ERROR DEACTIVATES AUTOMATICALLY AS SOON AS THE SUPPLY VOLTAGE FALLS BACK WITHIN THE REQUESTED LIMITS).	AUTOMATIC.
E99	<b>GENERAL INTERNAL BOARD ERROR</b>	INCORRECT SIGNAL RECOGNITION BY THE MODULATION BOARD MICRO-PROCESSOR.	IF THE MODULATION BOARD DOES NOT RESET THE ERROR AUTOMATICALLY, REPLACE IT.	AUTOMATIC.

## 2. MAINTENANCE

### 2.2.16. ACTIVE FUNCTIONS SIGNALLING CODES

CODE	FUNCTION	DESCRIPTION
F07	<b>CHIMNEY SWEEP ACTIVE</b>	YOU CAN ACTIVATE IT, BY KEEPING HOLD AT THE SAME TIME AND FOR 3 SECONDS THE KEYS  AND  YOU CAN DEACTIVATE IT BY PRESSING THE KEY  . THIS FUNCTION BRINGS THE BOILER TO ITS MINIMUM AND MAXIMUM HEATING POWER FOR 15 MINUTES DEACTIVATING THE MODULATION FUNCTION. GENERALLY USED FOR PERFORMING THE COMBUSTION AND CALIBRATION TESTS.
F08	<b>HEATING CIRCUIT ANTI-FREEZE</b>	IT ACTIVATES AUTOMATICALLY WHEN THE HEATING PROBE DETECTS A TEMPERATURE OF 5°C. THE BOILER OPERATES AT MINIMUM GAS PRESSURE WITH THE DIVERTER VALVE SET TO 'WINTER' MODE. IT DEACTIVATES WHEN THE HEATING PROBE DETECTS A TEMPERATURE OF 30°C.
F09	<b>D.H.W CIRCUIT ANTI-FREEZE</b>	THE FUNCTION IS AUTOMATICALLY ENABLED WHEN THE D.H.W SENSOR DETECTS A TEMPERATURE OF 5 °C. THE BOILER OPERATES AT MINIMUM GAS PRESSURE WITH THE DIVERTER VALVE IN THE 'SUMMER' POSITION. THE FUNCTION IS DISABLED WHEN THE TEMPERATURE DETECTED BY THE SENSOR IS 10 °C IN THE D.H.W CIRCUIT.
F33	<b>SYSTEM AIR RELEASE CYCLE</b>	IT ACTIVATES AUTOMATICALLY AT FIRST BOILER START-UP, PERFORMING FOR 5 MINUTES A SERIES OF CYCLES DURING WHICH THE PUMP IS ACTIVATED FOR 40 SECONDS AND DEACTIVATED FOR 20 SECONDS. REGULAR OPERATION IS ALLOWED ONLY AFTER THIS FUNCTION IS COMPLETED. IT CAN ALSO ACTIVATE DURING NORMAL BOILER OPERATION, IF THE WATER PRESSURE SWITCH CONFIRMATION IS MISSING, WHEN THE CONTACT IS RE-CLOSED, A 2 MINUTES RELEASE CYCLE WILL BE PERFORMED.
FH	<b>FAST H2O</b>	YOU CAN ACTIVATE/DEACTIVATED IT BY HOLDING SIMULTANEOUSLY AND FOR 7 SECONDS THE RESET  AND  OF THE HEATING CIRCUIT  . THE "FAST H2O" FUNCTION GUARANTEES THE IMMEDIATE D.H.W SUPPLY AT THE REQUESTED TEMPERATURE.

## 2.2.17. GAS TYPE TRANSFORMATION

**ATTENTION**

*Make sure that the gas adduction tube is suitable for the new type of fuel with which the boiler is supplied.*

- › loosen the two screws '1' (fig.1) from the fastening bush, and remove the air suction tube;
- › unscrew the tube coupling that connects the gas valve to venturi;
- › unscrew the three fastening screws '2' (fig.1) of the venturi 'V' (fig.1) using a 10 key, as shown in figure 2;
- › remove the two screws '3' (fig.3) and apply pressure on the rear side of venturi 'C' (fig.3);
- › replace the body venturi with the one suitable for the type of supply gas (cod. 30-00207 for methane / cod. 30-00201 for GPL) and make sure the tooth 'D' (fig.3) is adjusted downwards on the aluminium ring nut (see fig.3);
- › remount the components following the demounting operations in reverse making sure that gasket 'G' is re-assembled as shown in fig.1;
- › set the boiler to operate with the new type of gas, changing the value of the parameter P02 'GAS TYPE SELECTION' from the control panel (see chapters 'MIAB3013 PARAMETERS TABLE' and 'ACCESSING AND PROGRAMMING THE PARAMETERS');
- › adjust the CO<sub>2</sub> combustion value as indicated in chapter 'CO<sub>2</sub>VALUE CHECKANDCALIBRATION'.

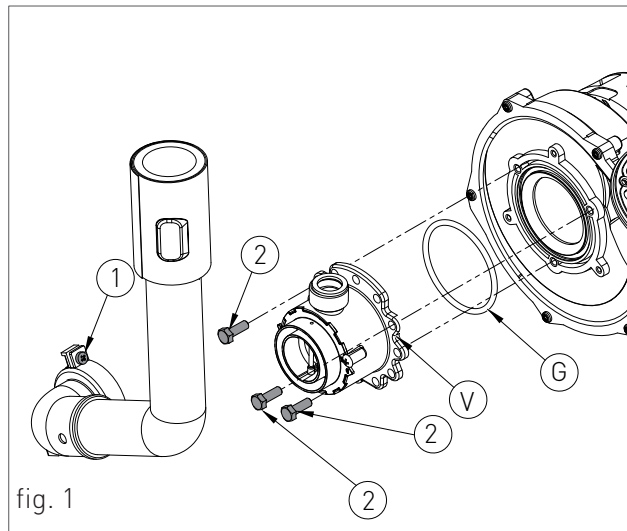

fig. 1

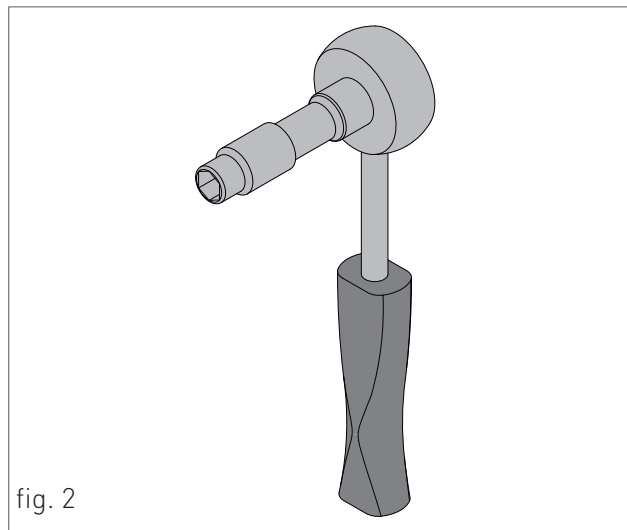

fig. 2

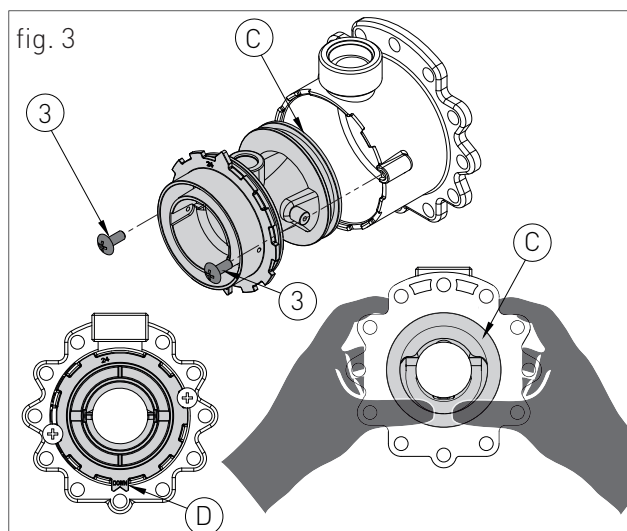

fig. 3



## 3. USER SECTION

The operations described in this section are addressed to all those who will use the machine. The machine must be used and accessed only by qualified operators that fully read and understood the User section, paying particular attention to the warnings.

## 3.1. USE

## 3.1.1. GENERAL USE WARNINGS

**WARNING**

*Before starting the boiler the User must make sure that the First start-up certificate has the stamp of the technical Support Centre proving the testing and the first start-up of the boiler.*

**WARNING**

*In order to take advantage of the guarantee provided by the manufacturer, the customer should carefully and exclusively observe the instructions given in the USER section of the manual.*

**ATTENTION**

*This machine may be used only for the purpose for which it has been designed: heat water to a temperature below boiling point at atmospheric pressure. Any other use is considered wrong and dangerous. The manufacturer is excluded from any contractual or out of contract responsibility for damage caused to people, animals or property due to incorrect use.*

**DANGER**

*The boiler should not be used by persons (including children) with reduced physical, sensory or mental capacities or without suitable knowledge or experience unless they are instructed on the device use or monitored by a person responsible for their safety.*

**DANGER**

*DO NOT obstruct the air vents of the location in which the gas device is installed to prevent the formation of toxic explosive mixes.*

**DANGER**

*If you sense a gas odour in the location in which the boiler is installed, proceed as follows:*

- › DO NOT use electrical switches, the telephone or any other device that might generate electrical discharges or sparks;
- › Immediately open all doors and windows to create an air exchange that can quickly clean the location;
- › Close the gas valves;
- › Request immediate intervention of qualified staff.

**DANGER**

*The use of the electrical power boiler implies respecting some fundamental rules such as:*

- › DO NOT touch the device with wet and/or humid parts and/or with bare feet;
- › DO NOT pull the electrical cables;
- › DO NOT leave the device exposed to atmospheric agents (rain, sun, etc.) unless specifically intended;
- › in case of cable damage, turn off the device and contact qualified professional staff to replace it.

## 3.1.2. CONTROL PANEL

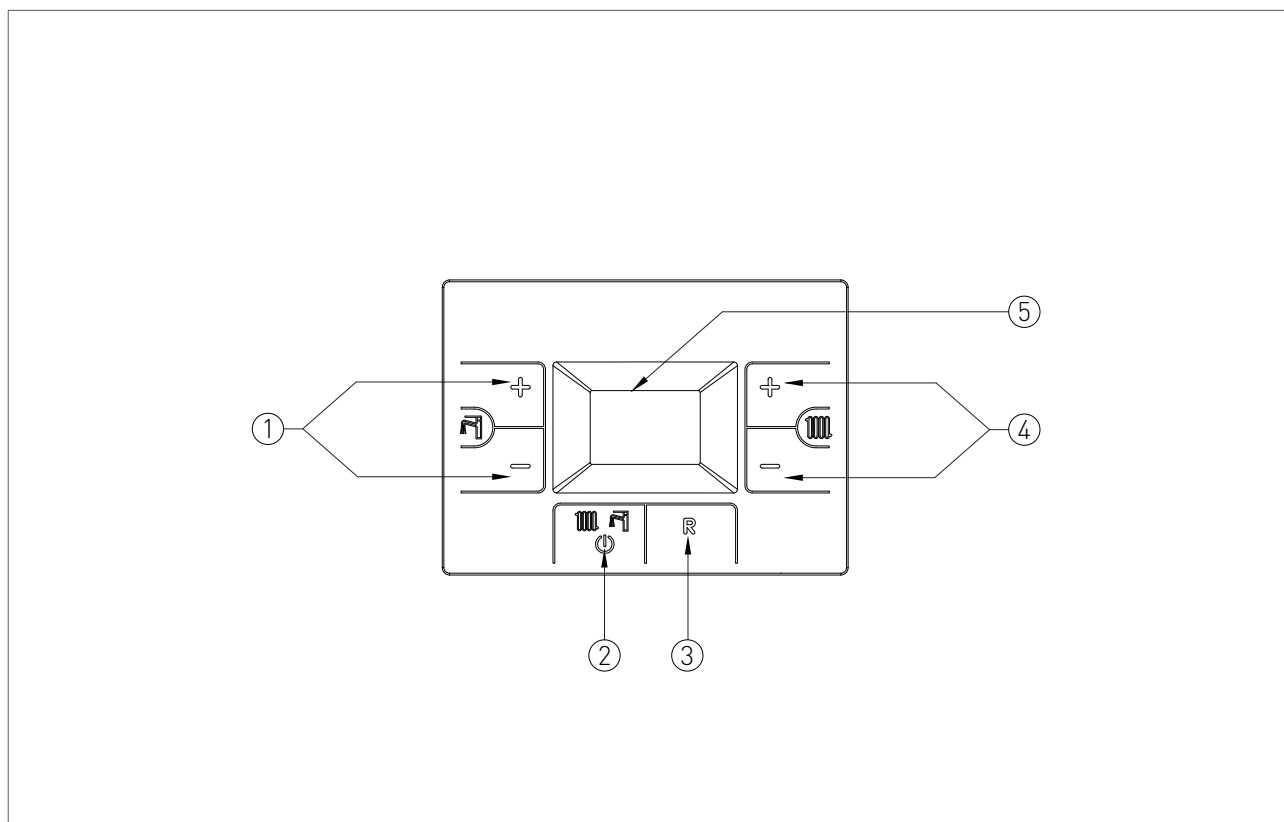

## KEY

1. DOMESTIC HOT WATER TEMPERATURE ADJUSTMENT KEYS
2. OPERATING MODE SELECTION KEY: SUMMER / HEATING ONLY / WINTER / OFF
3. RESET KEY: ANOMALY RESET
4. HEATING TEMPERATURE ADJUSTMENT KEYS
5. DISPLAY





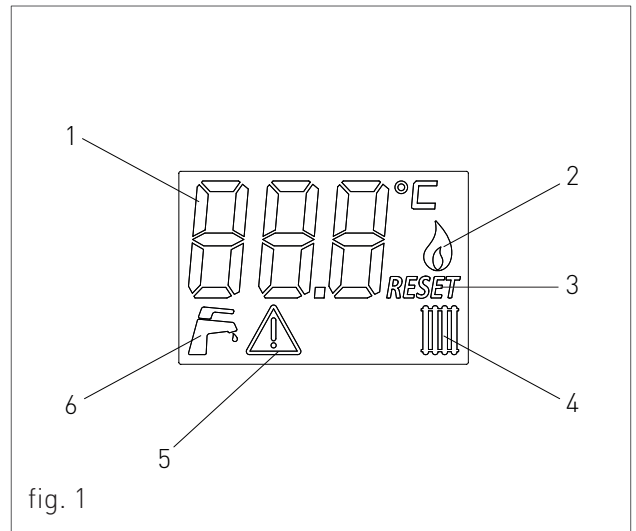

#### 3.1.3. DISPLAY ICONS

##### KEY



1. INDICATION OF PARAMETER NUMBER OR DISPLAYED INFO CODE.
2. FLAME PRESENT SIGNALLING.
3. ERROR DISPLAY THAT CAN BE RESET.
4. OPERATION IN HEATING MODE ENABLED.
5. PARAMETERS PROGRAMMING FUNCTION ACTIVE.
6. OPERATION IN DOMESTIC MODE ENABLED.



### 3.1.4. INFO MENU DISPLAY DATA

To view the boiler data from the info menu you just have to press at the same time the keys  and  of the DHW circuit  for 2 seconds. It will be displayed the info code alternated to the associated value. Use keys  and  of the heating circuit  to scroll through the list of displayed data. To exit display mode press the  key.

#### LIST OF DISPLAYED DATA

INFO CODE	ICON	DESCRIPTION
0		DOMESTIC CIRCUIT PROBE TEMPERATURE
1		HEATING CIRCUIT TEMPERATURE
2		BURNER ACTUAL OUTPUT POWER (EXPRESSED IN PERCENTAGE)
3		RETURN PROBE TEMPERATURE
4		EXTERNAL PROBE TEMPERATURE
5		FAN SPEED FREQUENCY

### 3.1.5. START-UP



Before starting the boiler make sure that it is powered and that the gas tap below the boiler is open.

To start the boiler press the function key  and select the desired operating mode. If the symbol is displayed fixed, it means that the function was activated.

### 3.1.6. OPERATING MODE

#### SUMMER MODE



In this mode the boiler meets only the demands of domestic hot water.

To switch the boiler to SUMMER operating mode, press the function key , the symbol  will appear fixed on the display, indicating that the function is enabled.

Whenever hot domestic water is needed the automatic start-up system will start the burner; this is indicated by displaying the symbol  blinking.

#### ONLY HEATING MODE



In this mode the boiler meets only the demands of heating.



To switch the boiler to ONLY HEATING operating mode, press the function key , the symbol  will appear fixed on the display, indicating that the function is enabled.

Whenever heating energy is needed to heat the rooms the automatic start-up system will start the burner; this is indicated by displaying the symbol  blinking.



#### WINTER MODE



In this mode the boiler meets the demands of heating and of domestic hot water.

To switch the boiler to WINTER operating mode, press the function key , the symbols  and  will appear fixed on the display, indicating that the function is enabled.

Whenever heating energy and domestic hot water are needed the automatic start-up system will start the burner; this is indicated by displaying the symbol  and  blinking.



#### ADJUSTING THE HEATING TEMPERATURE



You can adjust the temperature using keys  and  of the heating circuit .

- press key  to decrease the temperature.
- press key  to increase the temperature.

The heating temperature adjustment field ranges from 30 °C to 80 °C (25 °C – 45 °C for floor systems).

#### DOMESTIC HOT WATER TEMPERATURE ADJUSTMENT

You can adjust the temperature using keys  and  of the domestic circuit .

- press key  to decrease the temperature.
- press key  to increase the temperature.

The hot domestic water temperature adjustment field ranges from 35 °C to 60 °C.

#### OFF MODE

In this mode the boiler no longer meets the heating and domestic hot water demands, the anti-freeze,

pump anti-locking and diverter valve anti-locking systems still remain active.

To switch the boiler to OFF operating mode, press the function key ; the message 'OFF' indicating that the function is enabled.

If the boiler was previously running, it will be turned off and the post-ventilation and post-circulation functions will be enabled.

If you have to deactivate the boiler for a long period of time, proceed as follows:

- › contact the Technical support centre that will empty the water system, where no anti-freeze is intended, and will cut off the power, water and gas supply.
- › Or leave the boiler in OFF operating mode keeping active the electrical and gas supplies so that the anti-freeze function may activate.

#### 3.1.7. INFORMATIONAL NOTE ON ANTI-FREEZE FUNCTION

The boiler is protected against freezing thanks to the electronic board preparation with functions that start the burner and heat the concerned parts when their temperature goes below the minimum pre-set values.



#### **WARNING**

*This function is available only if:*

- › the boiler is powered;
- › the gas supply is open;
- › the pressure of the system is proper;
- › the boiler is not blocked.

### 3.1.8. SYSTEM FILLING

To restore the water pressure inside the system open the loading tap "R" (fig. 1) and make sure using pressure gauge "M" (fig. 1), that the system pressure reaches 1.2 bar (see fig. 2).

After performing this operation, make sure that the loading tap "R" (fig. 1) is properly closed.

After the water pressure reset the boiler will automatically perform a 2 minutes system relief cycle. Throughout this function the display will show the code "F33". The boiler can work normally only after completing the operation.

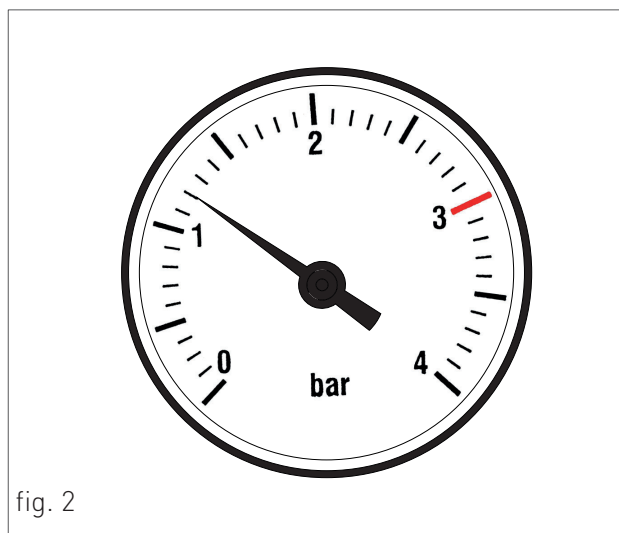
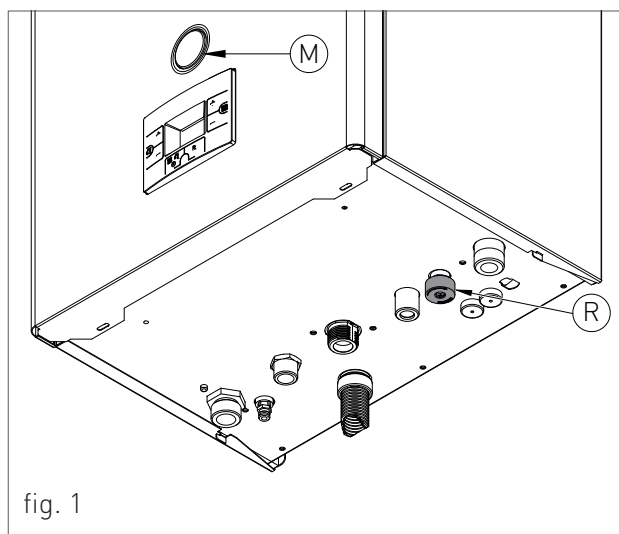

## 3.1.9. FAULT SIGNALLING CODES

The boiler might signal some faults by displaying a code. Below you have a list of the codes and of the operations to be performed in order to unlock the boiler.

CODE	FAULT	INTERVENTION
E01	<b>FLAME BLOCK</b>	<p>MAKE SURE THAT THE BOILER AND CONTACTOR GAS VALVES ARE OPEN.</p> <hr/> <p>PRESS THE RESET  BUTTON ON THE CONTROL PANEL TO RESET THE FAULT, AS SOON AS THE ERROR CODE DISAPPEARS FROM THE DISPLAY, THE BOILER WILL START AUTOMATICALLY.</p> <hr/> <p>IF THE BLOCK PERSISTS CONTACT THE TECHNICAL SUPPORT CENTRE.</p>
E02	<b>SAFETY THERMOSTAT (95 °C)</b>	CONTACT THE TECHNICAL SUPPORT CENTRE.
E03	<b>FUMES SAFETY THERMOFUSE (102 °C)</b>	CONTACT THE TECHNICAL SUPPORT CENTRE.
E04	<b>WATER MISSING IN THE SYSTEM</b>	<p>IF THE SYSTEM PRESSURE IS BELOW 1.2 BAR, FILL THE SYSTEM AS DESCRIBED IN CHAPTER "SYSTEM FILLING".</p> <hr/> <p>IF THE BLOCK PERSISTS CONTACT THE TECHNICAL SUPPORT CENTRE.</p>
E05	<b>HEATING PROBE</b>	CONTACT THE TECHNICAL SUPPORT CENTRE.
E06	<b>DOMESTIC CIRCUIT PROBE</b>	CONTACT THE TECHNICAL SUPPORT CENTRE.
E15	<b>RETURN PROBE</b>	CONTACT THE TECHNICAL SUPPORT CENTRE.
E16	<b>ELECTRIC FAN</b>	CONTACT THE TECHNICAL SUPPORT CENTRE.
E22	<b>PARAMETERS REQUEST</b>	<p><b>PROGRAMMING</b></p> <p>CUT OFF THE POWER SUPPLY FROM THE MAIN SWITCH AND THEN RESTORE IT, AS SOON AS THE ERROR CODE DISAPPEARS, THE BOILER WILL RESTART AUTOMATICALLY.</p> <hr/> <p>IF THE BLOCK PERSISTS CONTACT THE TECHNICAL SUPPORT CENTRE.</p>
E31	<b>REMOTE CONTROLLER INCOMPATIBLE</b>	CONTACT THE TECHNICAL SUPPORT CENTRE.
E98	<b>SUPPLY VOLTAGE</b>	CONTACT THE TECHNICAL SUPPORT CENTRE.

### 3. USE



---

CODE	FAULT	INTERVENTION
<b>E99</b>	<b>GENERAL INTERNAL BOARD ERROR</b>	CUT OFF THE POWER SUPPLY FROM THE MAIN SWITCH AND THEN RESTORE IT, AS SOON AS THE ERROR CODE DISAPPEARS, THE BOILER WILL RESTART AUTOMATICALLY.
		IF THE BLOCK PERSISTS CONTACT THE TECHNICAL SUPPORT CENTRE.

---

### 3.1.10. ACTIVE FUNCTIONS SIGNALLING CODES

To activate/deactivate the Fast H2O function please follow the instruction indicated in the paragraph 'ACTIVE FUNCTIONS SIGNALLING CODES'.

CODE	FUNCTION	INTERVENTION
F08	<b>H E A T I N G A N T I - F R E E Z E F U N C T I O N A C T I V E</b>	WAIT UNTIL THE OPERATION IS COMPLETED
F09	<b>D.H.W C I R C U I T A N T I - F R E E Z E F U N C T I O N A C T I V E</b>	WAIT UNTIL THE OPERATION IS COMPLETED
F33	<b>S Y S T E M A I R R E L E A S E C Y C L E I N P R O G R E S S</b>	WAIT UNTIL THE OPERATION IS COMPLETED
FH	<b>F A S T H 2 O</b>	YOU CAN ACTIVATE/ D E A C T I V A T E D I T B Y H O L D I N G S I M U L T A N E O U S L Y A N D F O R 7 S E C O N D S T H E R E S E T  AND  OF T H E H E A T I N G C I R C U I T  .

### 3.1.11. FAST H2O FUNCTION

The Fast H2O function keeps a constant temperature in the DHW circuit within the boiler, according to the temperature set by the user.

The Fast H2O function offers three advantages:

- › the hot water is immediately supplied at the requested temperature.
- › unnecessary delays are avoided by increasing the comfort of the final user.
- › water wastes are limited waiting that the water reaches the right temperature.

---

### 3.1.12. MAINTENANCE

To ensure proper boiler safety and efficiency, please check the device every year.

An accurate maintenance should improve system management.

---

### 3.1.13. COVER CLEANING

Clean the cover of the device using a wet cloth and come neutral soap.



#### **WARNING**

*DO NOT use abrasive or powder detergents as they might damage the plastic cover and control elements.*

---

### 3.1.14. DISPOSAL

The boiler and all its accessories must be differentiated, suitably disposed of in accordance with the standards in force.



The use of the symbol WEEE (Waste Electrical and Electronic Equipment) shows that this product can not be dismantled as domestic waste. Proper dismantle of this product helps preventing potentially negative consequences on human health and environment.



FLEXIHEAT UK LTD

www.flexiheatuk.com

01202 822221

## TERMS AND CONDITIONS OF THE FLEXIHEAT WARRANTY

Subject to the following terms and conditions

All boilers with a Flexiheat warranty offer customers the comfort of a parts only warranty subject to the following terms and conditions. During the period of the warranty, we will, at our option, repair or replace a boiler free of charge where it suffers a mechanical or an electrical breakdown as a result of defective workmanship or materials, subject to the following conditions and exclusions.

1. The boiler must have been installed and commissioned within 12 months of manufacture by a registered Gas Safe installer in accordance with the guidelines in the installation and servicing booklet provided with the boiler.
2. The 'Benchmark' commissioning sheet must be completed by the installer and left with the boiler for reference purpose.
3. The warranty will commence from the date of installation. Without proof of purchase i.e. an invoice or completed 'Benchmark' commissioning sheet, the warranty will commence from the date of manufacture as detailed on the appliance data plate.
4. To qualify for the full warranty period, the boiler must be registered within 30 days of installation. We will warranty the heat exchanger for 10 years, when a good quality magnetic filter, with air separator, such as a magna clean type or similar. Picture evidence must be sent to validate this warranty
5. At the end of each 12-month period, the boiler must be serviced by a Gas Safe registered engineer. Should this condition not be met the boiler warranty will lapse.
6. The warranty does not apply:
  - a) If the boiler is removed from its place of installation without our prior consent
  - b) To any defect, damage or breakdown caused by inadequate servicing of the boiler or by deliberate action, accident, misuse or third-party interference including modification or an attempted repair which does not fully comply with industry standards.
  - c) To any defect, damage or breakdown caused by the design, installation and maintenance of the central heating system.
  - d) To de-scaling or other work required as a result of hard water scale deposits or from damage caused by aggressive water or sludge resulting from corrosion. Indications that such work may be required include a noisy boiler, cold spots on radiators, sludge in pipes and poor circulation of the central heating system.
  - e) If the claim/contact procedure set out in section 5 is not adhered to
  - f) To any other costs or expenses caused by or arising as a result of the breakdown of a Flexiheat boiler
  - g) To any defect resulting from the incorrect installation of the boiler, the flue system or the facility for condensate disposal.
  - h) To any costs incurred during delays in fixing reported faults.
7. If we supply replacement part or replace a boiler it will not extend the period of the warranty. All replaced parts or boilers will become the property of Flexiheat Ltd.
8. The warranty applies only where a Flexiheat boiler has been installed in a domestic dwelling in mainland United Kingdom, Northern Ireland and I.O.W. to provide heat and/or hot water to the central heating system.

Our boiler warranty is offered in addition to the rights provided to a consumer by law. Details of these rights can be obtained from a Trading Standards Authority or a Citizen Advice Bureau.

For more information on this range, please click on the below link

<https://www.flexiheatuk.com/lpg-combi-boiler/>



**FLEXIHEAT UK LTD**

[www.flexiheatuk.com](http://www.flexiheatuk.com)

01202 822221