



FLEXIHEAT UK LTD
www.flexiheatuk.com
01202 822221

FHTERM

HEATING AND VENTILATION UNITS



FHTERM 0, 1 & 2



FHTERM 3 & 4

INTENDED USE

The Flexiheat "FHTERM" unit heaters with axial fans, consist of epoxy coated metal casings and either 2 or 3 rows of heating coils suitable for use with a water of temperature up to 150/100°C or with steam under pressure up to 0.6 MPa / 6 Bar. These industrial unit heaters are the perfect solution to a wet central heating system for industrially heating: production warehouses, workshops, storage warehouses, retail pavilions, show and sports halls etc.

You can also use the unit heaters in both a heating and ventilation mode, whereby you can bring fresh air into the units via roof or wall intakes, and via a mixing box you can determine the proportion of both the fresh air and recirculated air to the units. With two discharge options – downward or horizontal - or ceiling mounted or wall mounted - meet all likely space configurations. Downward discharge is particularly suited to complex areas where obstacles might impede airflows from a horizontal unit. However, the horizontal discharge units, with adjustable louvers, are ideal where directional heating (e.g. along production lines) is required.

DEVICE DESCRIPTION

Series of types of units include 5 sizes.

The unit consists of:

- > axial fan;
- > water heating coil (fin or bimetal) or steam heating coil (bimetal);
- > external casing;
- > single-row inlet grid

Fin water heating coils are made of the copper tubes with internal diameter of 12mm and of aluminum fins with spacing $s=2,4$ mm.

Bimetal water heating coils are made of steel tubes with external diameter $d=16$ mm as well as of spirally rolled aluminum ribbing with external diameter of the element $D=38$ mm and the ribs spacing $s=2,8$ mm. Steam heating coils are made of steel tubes with the external diameter $d=25$ mm and spirally threaded aluminum ribbing with external diameter $D=58$ mm and the ribs spacing 2,8mm or 5mm.

Units with fin water heating coils or bimetal heating coils are with internal threads and units with steam heating coils are with external threads.

In the units which are intended to operate as the ceiling units the outlet grid can be replaced with the slot diffuser or with the exhaust nozzle.

Slot diffuser enables heating people staying zone with secondary air stream.

Exhaust nozzle enables the increase the range of the supply air stream.

For mounting the units on the brackets at the wall or on the floor feet (FHTERM 0, 1, & 2;) or arms (FHTERM 3 & 4) located in the lower part of the casing are used.

In order to undersling the units to the ceiling 4 screws located on the both sides of the casing (FHTERM 0; 1; 2) are used or blind rivets nuts which enable suspending with use of the threaded bars (FHTERM 3; 4).

WORKING CONDITIONS

Units with fin water heating coil can be supplied with water of temperature 150°C or lower and with the operational pressure up to 1.5MPa, and with bimetal water heating coil they can be supplied with water of temperature up to 150/70°C and with operational pressure up to 1.6MPa / 16 BAR.

Units with steam heating coil (only wall mounted) can be supplied with steam under pressure of up to 0.6 MPA / 6 BAR.

FHTERM 0 & 1 unit fans are supplied only with single-phase motors 230V, 50 Hz.

FHTERM 2 units fans are supplied with three-phase motors 400V, 50 Hz or with single-phase motors 230V; 50Hz.

FHTERM 3; 4 units fans are supplied only with the three-phase motors 400V; 50Hz.

Three-phase motors of units 2; 3; 4; can be connected in Δ or Δ .

On buyer's request units FHTERM 1, 2, 3 & 4; can be equipped with the motors with the increased level of anti-explosive protection.

DESIGNATIONS

Heating unit	FHTERM-2-W;90/70;0,6 -L;III-K-T
Size	0; 1; 2; 3; 4;
Heating medium	water (W;°C; MPa); steam (P;MPa)
Heater	fin water (L; II / III); water bimetal (B; II / III); steam bimetal (B; II/2.8 / II/5);
Equipment	single-row grid (K); slot diffuser (N); nozzle (D)
Fan motor	three-phase (T); single-phase (J);

II/III - number of heating coil rows

II/2.8 / II/5 - steam heating coil ribs spacing

°C - heating medium temperature

MPa - permissible heating medium pressure

ADDITIONAL EQUIPMENT DESIGNATIONS

Roof intake	CD-2 -2xOS
Size	0; 1; 2; 3; 4;
Additional shields	1÷4pcs
Wall intake	CS-2
Size	0; 1; 2; 3; 4;
Roof base	PD-2
Size	0; 1; 2; 3; 4;
Air intake box	SC-2 -F-P
Size	0; 1; 2; 3; 4;
Additional equipment	filter (F), circulating air dampers (P)

EXAMPLE OF DESIGNATION

Of ceiling operating unit equipped with roof air intake box, roof base and air intake box with the hanging elements.

TERM - 2 - W; 90/70; 0,6 – L; III - K – T

Additional equipment: **CD – 2 + PD – 2 + SC – 2**

Hanging elements: **EZ** (according to the designations in the "Hangings" division).

TECHNICAL DATA

Basic dimensions

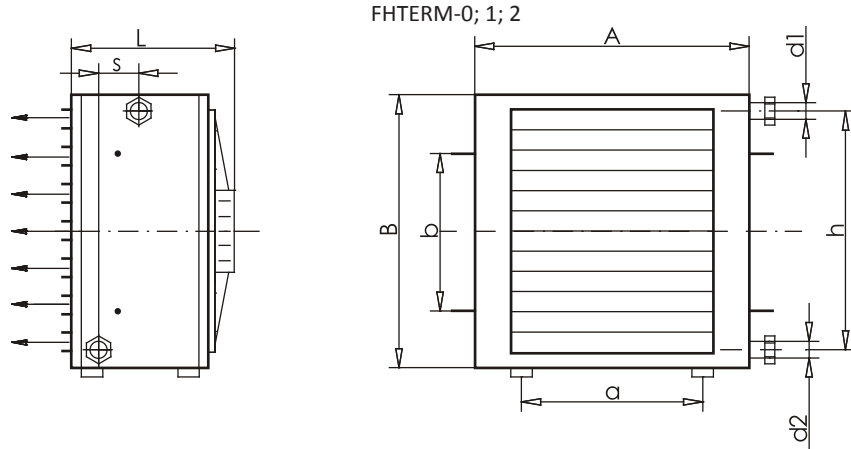

Unit size	A	B	L	a	b	d1=d2		d1/d2		h	s	Weight [kg]
						II	III	II; 2.8	II; 5			
Fin water heating coil units												
FHTERM0	412	412	330	280	200	½"	½"	-	-	300	70	16
FHTERM1	556	526	420	420	290	¾"	¾"	-	-	460	70	26
FHTERM2	677	684	436	420	380	¾"	1"	-	-	620	70	46
Bimetal water heating coil units												
FHTERM0	412	412	330	280	200	¾"	¾"	-	-	320	60	30
FHTERM1	556	526	420	420	290	¾"	¾"	-	-	445	60	38
FHTERM2	677	684	436	420	380	1"	1¼"	-	-	610	45	84
Bimetal steam heating coil units												
FHTERM0	412	412	330	280	200	-	-	¾"/½"	¾"/½"	360	-	35
FHTERM1	556	526	420	420	290	-	-	1"/¾"	1"/¾"	460	-	45
FHTERM2	677	684	436	420	380	-	-	1¼"/1"	1¼"/1"	620	-	72

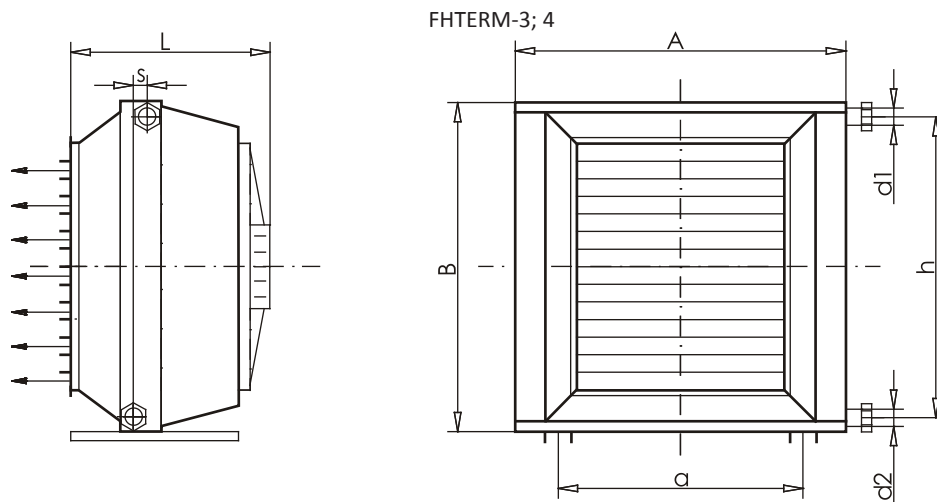

Unit size	A	B	L	a	d1=d2		d1/d2		h	s	Weight [kg]
					II	III	II; 2,8	II; 5			
Fin water heating coil units											
FHTERM3	1080	1017	589	800	1¼"	1½"	-	-	930	70	105
FHTERM4	1350	1257	630	1000	1 ½"	2"	-	-	1160	70	157
Bimetal water heating coil units											
FHTERM3	990	990	805	800	1¼"	1½"	-	-	790	40	175
FHTERM4	1229	1220	890	1000	1 ½"	2"	-	-	990	30	215
Bimetal steam heating coil units											
FHTERM3	1090	1090	805	800	-	-	2"/1½"	1½"/1¼"	930		180
FHTERM4	1320	1320	890	1000	-	-	2"/1½"	2"/1½"	1160		255

All dimensions are stated in mm.

In the table were presented the weights and the spacing of connectors of units with the III row water heating coils, the weights and spacing of connectors of units with the II row steam heating coils with the ribs spacing 2.8mm.

HEATING AND VENTILATION UNITS

Units fans parameters

Unit size	Fan type	Voltage [V]	Motor power [kW]	Current[A]	Speed [rpm]	IP	Insulation class	Operating temperature [°C]
FHTERM-0	HXM-300	230	0.055	0.40	1300	40	B	+40
FHTERM-1	FE035-4E	230	0.2	0.9	1400	54	F	+60
FHTERM-2	FE045-4E	230	0.61	2.8	1310	54	F	+60
	FE045-VD Δ	400	0.61	1.15	1340	54	F	+70
	FE045-VD λ	400	0.41	0.72	1000	54	F	+70
FHTERM-3	FE056-VD Δ	400	1.2	2.4	1330	54	F	+50
	FE056-VD λ	400	0.65	1.25	980	54	F	+50
FHTERM-4	FE063-VD Δ	400	2.6	4.8	1330	54	F	+65
	FE063-VD λ	400	1.6	2.7	1040	54	F	+65

Δ , λ three-phase motors connection type

Manufacturer reserves the rights to implement modifications.

Heat output of units with fin water heating coils

Unit size		TERMO-W-L Air					
flow [m³/h]		1150			1100		
Number of heating coil rows		II			III		
Water capacity [dm³]		1.0			1.2		
Water temp.[°C]	Inflow air temp. [°C]	Heat output [kW], outflow air temperature [°C] and resistance of water flow [kPa]					
		kW	°C	kPa	kW	°C	kPa
110/80	-15	15,0	20	1,5	20,0	34	1,5
	0	12,5	31	1,2	16,5	43	1,1
	+15	10,0	41	1,0	13,3	52	1,0
90/70	-15	13,6	17	2,9	18,0	29	2,6
	0	11,0	27	1,8	14,4	38	1,9
	+15	8,4	37	1,1	11,1	46	1,4
80/60	-15	11,9	13	2,2	15,8	24	2,0
	0	9,3	23	1,6	12,4	32	1,5
	+15	6,9	33	1,2	9,2	40	1,2
70/50	-15	10,3	9	1,6	13,2	19	1,5
	0	7,8	19	1,3	10,3	27	1,3
	+15	5,4	29	1,1	7,2	35	1,1
60/40	-15	8,6	5	1,2	11,5	13	1,2
	0	6,2	15	1,1	8,3	22	1,1
	+15	4,0	25	1,0	5,3	30	1,0

HEATING AND VENTILATION UNITS

Heat output of units with fin water heating coils

Unit size		FHTERM1-W-L					
Air flow [m ³ /h]		2700			2600		
Number of heating coil rows		II			III		
Water capacity [dm ³]		1.5			2,0		
Water temp. [°C]	Inflow air temp. [°C]	Heat output [kW], outflow air temperature [°C] and resistance of water flow [kPa]					
		kW	°C	kPa	kW	°C	kPa
110/80	-15	41,0	24	12,0	54,6	40	11,0
	0	34,1	35	8,4	45,2	48	8,0
	+15	27,4	44	5,5	36,4	56	5,2
90/70	-15	38,0	21	23,0	48,9	34	21,1
	0	30,5	31	15,0	39,4	42	13,6
	+15	23,6	40	9,1	34,0	49	8,1
80/60	-15	33,3	17	18,2	43,1	28	16,3
	0	26,1	26	11,0	33,8	36	10,0
	+15	19,3	36	6,0	25,1	43	5,5
70/50	-15	28,7	13	13,0	37,3	22	12,2
	0	21,7	22	7,7	28,3	30	7,0
	+15	15,2	31	3,8	19,9	37	3,4
60/40	-15	24,2	9	9,0	31,6	17	8,8
	0	17,2	18	5,1	22,9	24	4,6
	+15	11,2	27	2,1	14,8	31	1,9

Heat output of units with fin water heating coils

Unit size		FHTERM2-W-L											
Air flow [m ³ /h]		6200			6000			4750			4600		
Motor connection		Δ						∧					
Number of heating coil rows		II			III			II			III		
Water capacity [dm ³]		2,4			3,2			2,4			3,2		
Water temp. [°C]	Inflow air temp. [°C]	Heat output [kW], outflow air temperature [°C] and resistance of water flow [kPa]											
		kW	°C	kPa	kW	°C	kPa	kW	°C	kPa	kW	°C	kPa
110/80	-15	83,1	24	19,5	108,3	39	19,0	71,6	29	14,0	92,4	45	14,0
	0	68,9	34	13,0	89,7	48	13,5	59,3	39	10,1	76,5	53	9,8
	+15	55,4	44	8,8	72,2	56	8,7	47,7	48	6,5	61,6	60	6,4
90/70	-15	76,4	21	40,0	97,8	34	33,9	66,2	26	33,9	83,5	38	24,5
	0	61,4	31	30,6	78,6	41	21,7	53,2	35	21,7	67,2	46	16,6
	+15	47,2	40	19,0	60,5	49	14,3	40,9	44	14,3	51,6	53	8,4
80/60	-15	67,0	17	37,3	86,1	28	27,4	58,1	21	27,4	73,6	32	19,0
	0	52,5	26	21,7	67,4	35	16,6	45,5	30	16,6	57,7	39	12,2
	+15	38,7	36	12,2	49,9	43	8,4	33,6	38	8,4	42,7	46	6,8
70/50	-15	57,8	13	27,4	74,5	22	19,0	50,2	16	19,0	63,8	26	14,3
	0	43,7	22	14,3	56,4	30	10,3	38,0	25	12,2	48,4	33	8,4
	+15	30,5	31	6,8	39,5	37	5,4	26,5	33	5,9	33,9	40	4,1
60/40	-15	48,7	8	19,0	63,1	16	14,3	42,4	11	14,3	54,2	20	10,2
	0	35,1	18	10,2	45,6	24	6,8	30,6	20	7,9	39,2	26	5,8
	+15	22,4	27	4,1	29,4	31	3,0	19,6	28	3,2	22,5	33	2,4

HEATING AND VENTILATION UNITS

Heat output of units with fin water heating coils

Unit size		FHTERM3-W-L											
Air flow [m ³ /h]		10850			10500			8280			8000		
Motor connection		Δ						∩					
Number of heating coil rows		II			III			II			III		
Water capacity [dm ³]		4,8			7,5			4,8			7,5		
Water temp. [°C]	Inflow air temp. [°C]	Heat output [kW], outflow air temperature [°C] and resistance of water flow [kPa]											
		kW	°C	kPa	kW	°C	kPa	kW	°C	kPa	kW	°C	kPa
110/80	-15	170,8	26	15,0	224,0	41	12,0	150,5	30	12,6	195,2	46	9,8
	0	141,5	36	10,9	186,0	49	7,9	124,7	40	7,8	161,6	53	6,3
	+15	113,8	45	6,3	149,8	57	4,9	100,3	49	5,0	130,0	60	3,8
90/70	-15	157,8	23	17,2	201,7	35	13,1	138,5	27	14,1	178,5	39	10,5
	0	127,0	32	11,3	162,2	43	8,1	111,4	35	8,1	143,6	46	6,7
	+15	97,6	41	6,7	124,7	50	5,0	85,6	44	5,4	110,4	53	3,9
80/60	-15	138,4	18	13,1	177,5	29	9,6	121,6	22	11,3	157,3	32	8,1
	0	108,5	27	8,1	139,2	36	6,3	95,3	30	6,7	123,4	39	4,9
	+15	80,1	37	4,3	102,9	44	3,5	70,4	39	3,6	91,3	46	2,7
70/50	-15	119,5	14	9,6	153,7	23	6,7	105,1	16	8,1	136,4	26	6,2
	0	90,4	23	6,0	116,6	30	4,5	79,5	25	4,7	103,5	33	3,5
	+15	63,1	32	2,9	81,6	38	2,2	55,5	34	2,2	72,6	40	1,7
60/40	-15	100,8	9	6,7	130,4	17	5,4	88,8	12	5,8	115,9	20	4,4
	0	72,7	18	3,2	94,4	25	2,9	64,1	20	3,0	83,9	27	2,3
	+15	46,5	27	1,7	60,7	32	1,4	41,1	29	1,2	54,2	33	1,1

Heat output of units with fin water heating coils

Unit size		FHTERM4-W-L											
Air flow [m ³ /h]		19000			18500			14840			14500		
Motor connection		Δ						∩					
Number of heating coil rows		II			III			II			III		
Water capacity [dm ³]		7,5			11,5			7,5			11,5		
Water temp. [°C]	Inflow air temp. [°C]	Heat output [kW], outflow air temperature [°C] and resistance of water flow [kPa]											
		kW	°C	kPa	kW	°C	kPa	kW	°C	kPa	kW	°C	kPa
110/80	-15	260,5	20	4,0	348,8	34	3,1	228,0	25	3,1	298,3	40	2,2
	0	215,9	31	2,7	289,0	43	2,0	188,9	35	2,1	249,7	48	1,5
	+15	173,7	41	1,6	232,7	52	1,2	152,0	45	1,3	201,0	56	1,0
90/70	-15	241,4	18	4,2	314,8	29	3,2	210,7	22	3,3	271,3	34	2,4
	0	194,2	28	2,8	253,2	38	2,1	169,4	31	2,2	218,2	42	1,6
	+15	150,5	37	1,7	196,9	45	1,3	131,5	40	1,4	170,0	48	1,1
80/60	-15	211,5	14	3,3	276,6	24	2,5	184,8	17	2,6	238,8	28	1,9
	0	165,6	24	2,0	216,7	32	1,5	144,7	27	1,6	187,2	36	1,2
	+15	123,2	33	1,1	162,1	40	1,1	107,9	35	1,1	140,2	42	1,0
70/50	-15	182,2	10	2,5	239,1	18	1,9	159,3	13	1,9	206,7	22	1,4
	0	137,7	20	1,5	181,1	27	1,1	120,5	22	1,1	156,6	30	1,1
	+15	96,7	29	1,0	128,0	34	1,0	84,8	31	1,0	111,0	37	1,0
60/40	-15	153,5	6	1,7	202,3	13	1,3	134,4	8	1,3	175,1	16	1,1
	0	110,6	16	1,1	146,1	22	1,0	97,0	18	1,0	126,7	24	1,0
	+15	71,0	25	1,0	94,7	29	1,0	62,4	27	1,0	82,4	31	1,0

HEATING AND VENTILATION UNITS

Heat output of units with bimetal water heating coils

Unit size		FHTERM0-W-B					
Air flow [m ³ /h]		1150			1100		
Number of heating coil rows		II			III		
3		1,2			1,7		
Water temp.[°C]	Inflow air temp. [°C]	Heat output [kW], outflow air temperature [°C] and resistance of water flow [kPa]					
		kW	°C	kPa	kW	°C	kPa
80/60	-15	11,0	11	1,8	13,8	19	1,2
	0	8,7	22	1,3	10,9	28	1,1
	+15	6,5	32	1,1	8,2	37	1,0
90/70	-15	12,5	15	2,2	15,7	24	1,5
	0	10,1	25	1,5	12,7	33	1,3
	+15	7,9	36	1,2	9,9	42	1,1
110/80	-15	14,0	18	1,3	17,5	28	1,2
	0	11,6	29	1,1	14,6	38	1,0
	+15	9,4	40	1,0	11,8	48	1,0
130/90	-15	15,4	22	1,1	19,5	33	1,1
	0	13,1	33	1,0	16,5	43	1,0
	+15	10,9	44	1,0	13,8	53	1,0
150/100	-15	17,0	25	1,0	21,3	38	1,0
	0	14,6	37	1,0	18,5	48	1,0
	+15	12,5	48	1,0	15,7	59	1,0

Heat output of units with bimetal water heating coils

Unit size		FHTERM1-W-B					
Air flow [m ³ /h]		2700			2600		
Number of heating coil rows		II			III		
Water capacity [dm ³]		1,8			2,5		
Water temp.[°C]	Inflow air temp. °C	Heat output [kW], outflow air temperature [°C] and resistance of water flow [kPa]					
		kW	°C	kPa	kW	°C	kPa
80/60	-15	23,6	8	11,0	31,9	17	9,2
	0	18,6	19	7,0	25,2	27	5,7
	+15	13,9	30	3,9	18,8	36	3,2
90/70	-15	26,9	11	14,0	36,3	21	11,8
	0	21,7	22	9,6	29,3	31	7,7
	+15	16,9	33	5,8	22,8	40	4,7
110/80	-15	29,8	14	7,0	40,4	25	6,5
	0	24,8	25	5,5	33,6	36	4,5
	+15	20,1	36	3,6	27,2	45	3,0
130/90	-15	32,9	17	5,5	44,8	30	4,5
	0	28,0	28	4,0	38,1	40	3,2
	+15	23,4	40	2,7	31,7	51	2,3
150/100	-15	36,1	20	4,2	49,3	34	3,5
	0	31,3	32	3,2	42,6	45	2,7
	+15	26,6	44	2,3	36,3	56	2,0

HEATING AND VENTILATION UNITS

Heat output of units with bimetal water heating coils

Unit size		FHTERM2-W-B											
Air flow [m ³ /h]		6200			6000			4750			4600		
Motor connection		Δ						∩					
Number of heating coil rows		II			III			II			III		
Water capacity [dm ³]		3,7			5,6			3,7			5,6		
Water temp. [°C]	Inflow air temp. [°C]	Heat output [kW], outflow air temperature [°C] and resistance of water flow [kPa]											
		kW	°C	kPa	kW	°C	kPa	kW	°C	kPa	kW	°C	kPa
80/60	-15	52,9	10	16,5	70,1	20	12,9	44,8	13	11,8	59,0	24	9,1
	0	41,7	21	10,3	55,3	29	8,0	35,4	23	7,4	46,5	32	5,7
	+15	31,2	31	5,7	41,4	38	4,5	26,4	33	4,1	34,8	40	3,2
90/70	-15	60,3	13	19,1	79,6	25	16,6	51,0	17	15,3	67,0	29	11,7
	0	48,8	24	14,0	64,4	34	10,8	41,3	27	10,0	54,2	38	7,7
	+15	37,9	35	8,4	51,0	43	6,6	32,1	37	6,0	42,1	46	4,6
110/80	-15	66,8	16	11,7	88,9	29	9,2	56,7	20	8,4	74,9	34	6,5
	0	55,7	28	8,1	74,0	39	6,4	47,2	31	5,8	62,3	43	4,5
	+15	45,1	39	5,4	59,9	49	4,2	38,2	41	3,8	50,5	52	3,0
130/90	-15	73,9	20	8,0	98,6	35	6,4	62,7	24	5,8	83,2	40	4,5
	0	63,0	31	5,8	83,9	45	4,6	53,4	35	4,2	70,8	49	3,3
	+15	52,5	43	4,0	69,9	54	3,0	44,5	46	3,0	59,0	58	2,3
150/100	-15	81,2	23	6,2	108,6	39	4,9	69,0	28	4,5	91,8	45	3,5
	0	70,3	35	4,6	94,0	50	3,7	59,7	39	3,4	79,3	55	2,6
	+15	59,9	47	3,4	80,0	60	2,7	50,8	50	2,3	67,5	65	2,0

Heat output of units with bimetal water heating coils

Unit size		FHTERM3-W-B											
Air flow [m ³ /h]		10850			10500			8280			8000		
Motor connection		Δ						∩					
Number of heating coil rows		II			III			II			III		
Water capacity [dm ³]		6,7			9,9			6,7			9,9		
Water temp. [°C]	Inflow air temp. [°C]	Heat output [kW], outflow air temperature [°C] and resistance of water flow [kPa]											
		kW	°C	kPa	kW	°C	kPa	kW	°C	kPa	kW	°C	kPa
80/60	-15	93	7	5,8	127	16	4,8	81	9	4,4	110	19	3,6
	0	73	18	3,6	100	26	3,0	64	20	2,8	87	28	2,2
	+15	55	29	2,0	75	35	1,7	48	31	1,5	65	37	1,2
90/70	-15	106	10	7,5	144	21	6,2	92	13	5,7	125	24	4,6
	0	86	21	4,9	116	30	4,0	75	24	3,7	101	33	3,0
	+15	67	33	3,0	91	40	2,5	58	34	2,3	78	42	1,8
110/80	-15	117	13	4,1	161	24	3,4	106	16	3,1	139	28	2,5
	0	98	25	2,8	133	35	2,4	85	27	2,2	116	38	1,8
	+15	79	36	1,8	108	45	1,6	69	38	1,5	94	48	1,2
130/90	-15	129	16	2,8	178	29	2,4	113	19	2,2	154	33	1,8
	0	110	28	2,0	151	40	1,7	97	31	1,6	131	43	1,3
	+15	92	39	1,4	125	50	1,2	80	42	1,1	109	53	1,0
150/100	-15	142	19	2,2	195	33	1,8	124	22	1,7	170	37	1,4
	0	123	31	1,6	169	44	1,4	108	34	1,3	147	49	1,0
	+15	105	43	1,2	144	55	1,0	92	46	1,0	125	59	1,0

HEATING AND VENTILATION UNITS

Heat output of units with bimetal water heating coils

Unit size		FHTERM4-W-B											
Air flow [m ³ /h]		19000			18500			14840			14500		
Motor connection		Δ					人						
Number of heating coil rows		II			III			II			III		
Water capacity [dm ³]		10,6			16,0			10,6			16,0		
Water temp. [°C]	Inflow air temp. [°C]	Heat output [kW], outflow air temperature [°C] and resistance of water flow [kPa]											
		kW	°C	kPa	kW	°C	kPa	kW	°C	kPa	kW	°C	kPa
80/60	-15	164	7	16,9	223	16	13,0	141	10	12,5	191	19	10,0
	0	129	18	10,0	176	26	8,6	111	21	7,8	151	29	6,3
	+15	96	29	5,8	131	36	4,8	83	31	4,3	113	37	3,5
90/70	-15	186	10	21,0	253	21	18,0	161	16	16,0	217	24	13,0
	0	151	22	14,0	205	30	11,0	131	23	10,0	176	33	8,6
	+15	117	33	8,6	159	40	7,1	101	35	6,4	136	42	5,2
110/80	-15	201	13	11,0	282	24	9,9	178	16	8,9	242	28	7,3
	0	187	25	8,2	235	35	6,8	149	27	6,1	202	38	5,0
	+15	139	36	5,4	190	45	4,5	120	38	4,0	163	48	3,3
130/90	-15	228	15	8,0	313	29	6,8	197	19	6,1	268	33	5,0
	0	194	29	6,2	266	40	5,0	169	31	4,4	228	44	3,6
	+15	162	40	4,1	222	50	3,4	140	42	3,0	190	53	2,5
150/100	-15	250	19	6,3	344	33	5,3	216	23	4,7	296	38	3,9
	0	217	31	4,7	298	44	4,0	187	35	3,5	256	49	2,9
	+15	184	43	3,4	253	55	2,8	160	46	2,5	218	59	2,1

Heat output of units with steam heating coils

Unit size		FHTERM0-P-B					
Air flow [m ³ /h]		1100					
Ribs spacing [mm]		2,8			5,0		
Steam pressure [MPa]	Inflow air temp. [°C]	Heat output [kW], outflow air temperature [°C] and quantity of steam[kg/h]					
		kW	°C	kg/h	kW	°C	kg/h
0,05	-15	22,7	39	47	14,6	19	30
	0	19,6	49	41	12,7	32	26
	+15	16,7	59	35	10,9	44	23
0,1	-15	24,3	43	51	15,6	22	33
	0	21,3	54	44	13,7	34	29
	+15	18,3	64	38	11,9	46	25
0,2	-15	26,7	48	56	17,1	26	36
	0	23,6	59	49	15,2	38	32
	+15	20,6	70	43	13,4	50	28
0,4	-15	30,2	57	63	19,4	31	40
	0	27,0	68	57	17,4	44	36
	+15	23,9	79	50	15,6	56	32
0,6	-15	32,5	62	68	20,9	34	44
	0	29,3	74	62	18,9	48	39
	+15	26,2	85	55	17,0	60	36

HEATING AND VENTILATION UNITS

Heat output of units with steam heating coils

Unit size		FHTERM1-P-B					
Air flow [m ³ /h]		2700			2700		
Ribs spacing [mm]		2,8			5,0		
Steam pressure [MPa]	Inflow air temp. [°C]	Heat output [kW], outflow air temperature [°C] and quantity of steam[kg/h]					
		kW	°C	kg/h	kW	°C	kg/h
0,05	-15	50,6	34	106	32,8	17	70
	0	43,9	45	92	28,6	29	60
	+15	37,4	55	78	24,5	41	51
0,1	-15	54,3	37	114	36,2	19	74
	0	47,5	49	100	31,0	32	65
	+15	40,9	59	86	26,9	44	56
0,2	-15	59,5	42	125	38,6	22	81
	0	52,7	54	110	34,4	35	72
	+15	46,1	65	96	30,2	48	63
0,4	-15	67,2	50	141	43,7	27	91
	0	60,3	62	126	39,3	40	82
	+15	53,5	73	112	35,1	53	74
0,6	-15	72,5	55	152	47,1	30	98
	0	65,5	67	137	42,7	44	89
	+15	58,7	78	123	38,5	57	81

Heat output of units with steam heating coils

Unit size		FHTERM-2-P-B											
Air flow [m ³ /h]		6200					4750						
Motor connection		Δ					∩						
Ribs spacing [mm]		2,8			5,0		2,8			5,0			
Steam pressure [MPa]	Inflow air temp. [°C]	Heat output [kW], outflow air temperature [°C] and quantity of steam[kg/h]											
		kW	°C	kg/h	kW	°C	kg/h	kW	°C	kg/h	kW	°C	kg/h
0,05	-15	94,3	30	198	60,3	13	126	81,0	35	168	51,9	17	109
	0	81,0	41	172	52,6	26	110	69,4	46	145	45,2	30	95
	+15	69,8	52	143	45,1	39	94	59,1	56	124	38,7	42	81
0,1	-15	101,0	33	212	64,7	16	135	85,8	38	180	55,6	19	117
	0	88,6	45	186	57,0	29	120	75,1	50	157	48,9	32	102
	+15	76,4	56	160	49,4	41	103	64,4	60	136	42,4	44	89
0,2	-15	110,9	38	232	70,9	19	149	94,2	44	197	61,0	23	128
	0	98,2	50	206	63,2	32	132	83,3	55	178	54,3	36	114
	+15	86,0	61	180	55,6	44	116	72,8	66	153	47,7	48	100
0,4	-15	125,2	45	263	81,0	23	168	106,4	51	223	68,9	28	145
	0	112,4	57	236	72,3	36	152	95,3	63	200	62,1	41	130
	+15	100,0	68	210	64,6	49	135	84,7	74	177	55,4	54	116
0,6	-15	136,0	49	283	86,4	26	181	114,7	57	240	74,3	31	156
	0	122,1	62	256	78,5	40	165	103,5	69	217	67,5	45	141
	+15	109,5	73	230	70,8	53	148	92,7	79	194	60,8	57	127

HEATING AND VENTILATION UNITS

Heat output of units with steam heating coils

Unit size		FHTERM3-P-B											
Air flow [m³/h]		10850						8280					
Motor connection		Δ						人					
Ribs spacing [mm]		2,8			5,0			2,8			5,0		
Steam pressure [MPa]	Inflow air temp. [°C]	Heat output [kW], outflow air temperature [°C] and quantity of steam[kg/h]											
		kW	°C	kg/h	kW	°C	kg/h	kW	°C	kg/h	kW	°C	kg/h
0,05	-15	189	30	398	121	14	255	165	35	347	107	17	225
	0	164	42	346	106	27	223	143	46	301	94	30	196
	+15	140	53	295	91	39	191	122	50	256	80	42	168
0,1	-15	203	34	427	130	16	274	177	38	372	115	19	241
	0	178	45	374	115	29	241	155	50	326	101	32	212
	+15	153	56	323	99	42	209	133	60	287	87	45	184
0,2	-15	223	38	469	143	19	301	194	44	408	126	23	265
	0	197	50	415	127	32	268	172	55	361	112	36	235
	+15	173	62	363	112	45	235	150	66	316	98	48	207
0,4	-15	252	45	529	161	24	339	219	51	461	142	28	299
	0	226	58	475	146	37	306	197	63	413	128	41	269
	+15	201	69	424	130	50	274	174	74	367	114	54	240
0,6	-15	271	50	571	174	27	366	237	56	497	153	31	322
	0	245	63	516	157	42	330	214	68	449	139	44	293
	+15	220	74	463	143	53	300	191	80	402	125	57	263

Heat output of units with steam heating coils

Unit size		FHTERM4-P-B											
Air flow [m³/h]		19000						14840					
Motor connection		Δ						人					
Ribs spacing [mm]		2,8			5,0			2,8			5,0		
Steam pressure [MPa]	Inflow air temp. [°C]	Heat output [kW], outflow air temperature [°C] and quantity of steam[kg/h]											
		kW	°C	kg/h	kW	°C	kg/h	kW	°C	kg/h	kW	°C	kg/h
0,05	-15	320	29	673	204	13	430	276	33	580	178	16	375
	0	278	40	585	178	26	375	239	45	503	154	30	324
	+15	237	51	499	153	38	322	204	55	492	133	41	280
0,1	-15	343	32	722	219	15	461	296	37	622	191	18	402
	0	301	44	633	193	28	406	259	48	544	168	31	353
	+15	260	55	546	167	41	352	223	59	469	146	44	306
0,2	-15	377	37	792	240	18	506	325	42	682	209	22	441
	0	334	49	702	214	31	451	287	54	604	186	35	392
	+15	292	60	615	188	44	396	251	64	528	164	47	345
0,4	-15	426	43	894	272	22	571	367	49	771	237	26	498
	0	382	56	803	245	36	516	329	61	691	213	40	449
	+15	340	67	715	219	49	461	292	73	614	191	52	401
0,6	-15	459	48	964	293	25	613	395	54	831	255	30	537
	0	415	60	872	266	39	560	357	67	751	232	43	487
	+15	372	72	783	240	52	505	320	78	673	209	56	439

Directed vertically down hot air stream range

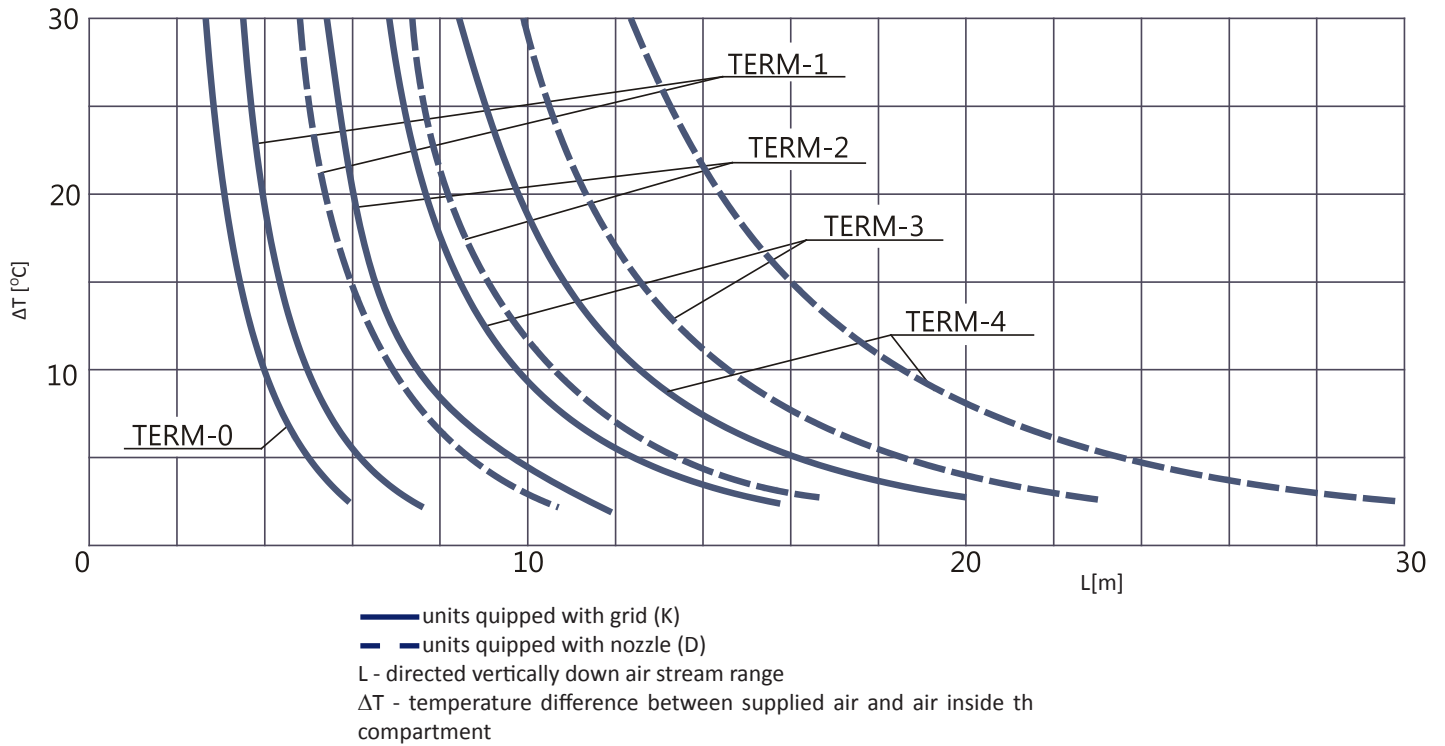

Isothermal air stream ranges

Unit size	Isothermal stream ranges [m]*	
	with grid	with nozzle
FHTERM-0	9	11
FHTERM-1	13	18
FHTERM-2	22	31
FHTERM-3	30	47
FHTERM-4	42	65

* - at the final velocity in air stream axe 0,5 m/s and average velocity in air stream ~0,2m/s.

Units noise level

Unit size	Fan type	Operation noise level dB(A) at the distance					
		with 1~230V;50Hz motor		with 3~400V;50Hz motor			
		1m / 1m	5m / 5m	1m / 1m	5m / 5m	1m / 1m	5m / 5m
FHTERM-0*	HXM-300	53	48	-	-	-	-
FHTERM-1**	FE-035-4E	60,5	54	-	-	-	-
FHTERM-2**	FE045-4E/FE045-VD	65	57,5	65	57,5	61	53,5
FHTERM-3***	FE056-VD	-	-	76	66,5	68,5	59
TFHERM-4***	FE063-VD	-	-	80,5	71	74,5	65

Operational noise level – acoustic pressure level with taking into consideration directional coefficient Q=2 and compartment *A=50m²; **A=100m²; ***A=300m² absorption ability.

OUTLET DIFFUSERS FOR THE UNITS

TERM 0; 1; 2

Unit with single-row outlet grid (K)

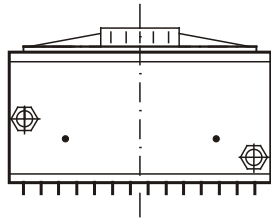

Slot diffuser (N)

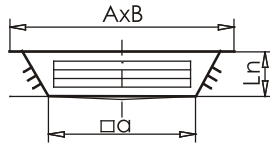

Outlet nozzle (D)

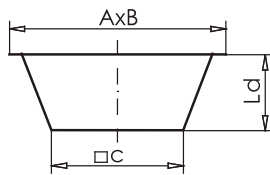

TERM 3; 4

Unit with single-row outlet grid (K)

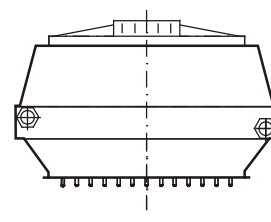

Slot diffuser (N)

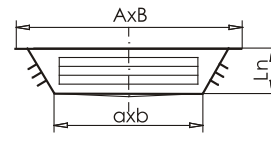

Outlet nozzle (D)

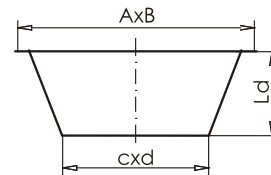

Slot diffuser (N)

Unit size	A x B	a x b	Ln
FHTERM-0	412 x 412	275 x 275	83
FHTERM-1	555 x 525	355 x 355	100
FHTERM-2	677 x 684	445 x 445	135
FHTERM-3	886 x 1010	670 x 794	145
FHTERM-4	1110 x 1251	895 x 1035	145

Outlet nozzle (D)

Unit size	A x B	c x d	Ld
FHTERM-0	412 x 412	278 x 278	150
FHTERM-1	555 x 525	350 x 350	190
FHTERM-2	677 x 684	450 x 450	240
TFHERM-3	886 x 1010	626 x 750	360
FHTERM-4	1110 x 1251	850 x 990	460

All dimensions are stated in mm.

The units are supplied with the single-row grid as a standard.

Grids have the movable blades enabling the air stream direction and reach adjustment.

Ceiling units can be equipped with:

- > slot diffusers (N) (air supply to 4 sides);
- > outlet nozzles (D).

Wall units can be also equipped with outlet nozzles (D).

Slot diffusers are enabling heating people staying zones with the secondary air stream.

Unit FHTERM 0; 1 with slot diffuser can be suspended on the height max. 4m whereas unit FHTERM with slot diffuser can be suspended on the height max. 6 m.

Outlet nozzles enable increase of air supply range.

ADDITIONAL EQUIPMENT

CD ROOF INTAKE

Roof intakes are intended to draw fresh air from above the roof and to protect the object against precipitations. In case of strong winds above 30m/s at the intake it's recommended to install additionally shields. In order to protect against pollution and insects the intakes have installed the nets on 2 sides (for CD-4 or the amount of outside air over 40% roof intake may be equipped with nets and shields on four sides. Air intakes are adapted for connecting with PD roof bases.

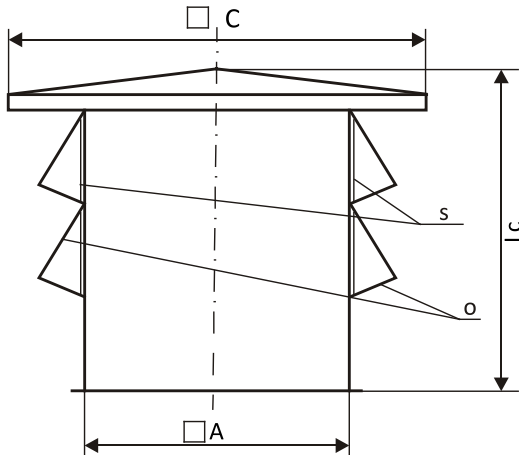

Unit size	Intake size	□ A	Lc	□ C	Weight [kg]
FHTERM0	CD-0	470	530	658	16,8
FHTERM1	CD-1	520	580	728	20,0
FHTERM2	CD-2	660	700	924	30,0
FHTERM3	CD-3	720	800	1008	46,2
FHTERM4	CD-4	810	950	1134	62,4

s - net
o - shield

Roof bases are whole made of galvanized steel sheets.

PD ROOF BASE

Roof bases are intended for installing cd roof air intakes and sc intake boxes of the term units

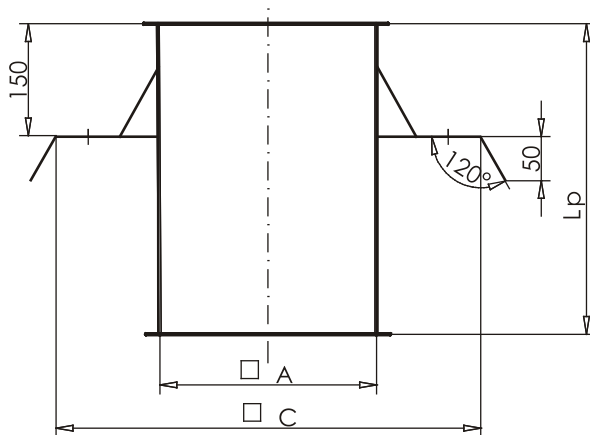

Unit size	Base size	□ A	Lc	□ C	Weight [kg]
FHTERM0	PD-0	470	600	690	28
FHTERM1	PD-1	520	600	740	31
FHTERM2	PD-2	660	600	1000	39
FHTERM3	PD-3	720	800	1080	50
FHTERM4	PD-4	810	800	1170	56

Roof bases are made of galvanized steel sheets.
All dimensions are stated in mm.

SC INTAKE BOXES

FOR CEILING AND WALL HEATING-VENTILATING UNITS

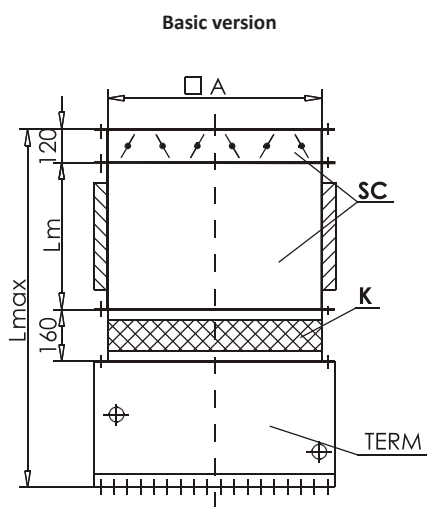

- SC - intake box
- K - flexible connector
- t - circulating air dampers
- f - filter

Intake boxes are used to draw the mix the fresh and circulating air.

In basic version they consist of:

- > fresh air damper
- > mixing chamber with circulating air inlet grids.

For connection of the intake box to the unit it is necessary to use flexible connector (K) delivered as a optional equipment.

Fresh air damper is operated with the actuator.

Mixing chamber has 2 grids (manually adjusted) in the circulating air inlet holes enabling setting the participation of circulating air in total Air flow.

Unit size	Box size	□ A	Lm	Lmax	Weight [kg]	
					SC basic version	SC version with filter and dampers
FHTERM0	SC-0	470	310	830	19	28
FHTERM1	SC-1	520	310	930	23	35
FHTERM2	SC-2	660	410	1040	30	44
FHTERM3	SC-3	720	510	1315	36	54
FHTERM4	SC-4	810	610	1465	41	63

All dimensions are stated in mm.

Intake boxes can be also have following additional elements:

- > filter (F) class G3;
- > circulating air dampers (P) with actuators.

Inlet boxes with additional elements are made after agreement with the manufacturer.

In agreement with the manufacturer intake boxes can be also made with the mixing chamber with one circulating air inlet grid.

Air capacities of the units with standard SC intake boxes

Unit size	Fan type	Air flow [m ³ /h]
FHTERM0	HXM-300	1000
FHTERM1	FE-035-4E	2340
FHTERM2	FE045-4E	5310
	FE045-VD Δ	5400
	FE045-VD \curvearrowright	4140
FHTERM3	FE056-VD Δ	9450
	FE056-VD \curvearrowright	7200
FHTERM4	FE063-VD Δ	16650
	FE063-VD \curvearrowright	13050

Δ , \curvearrowright three-phase motors connection type

Heat output of the units with SC intake boxes in the standard version are decreased by about ~5%

ADJUSTING RANGES OF SC INTAKE BOXES IN THE STANDARD VERSION

SC Intake vent Boxes in the standard version for all the TERM units are supplied with the constant recommended angle of circulating air closing equal 60°.

The ranges of fresh air dampers adjustment, participation of fresh air in total Air flow at the constant recommended angle of circulating air closing

Unit size	Box size	The range of adjusting the fresh air damper	Closing angle of circulating air grids	% of fresh air participation in total efficiency	Fresh air participation [m ³ /h]	Total air flow [m ³ /h]
FHTERM0	SC-0	open-closed	60°	10%÷75%	80÷750	830÷1000
FHTERM1	SC-1	open-closed	60°	10%÷75%	190÷1760	1940÷2340
FHTERM2	SC-2	open-closed	60°	10%÷75%	450÷4050*	4480÷5400*
FHTERM3	SC-3	open-closed	60°	10%÷75%	780÷7090*	7840÷9450*
FHTERM4	SC-4	open-closed	60°	10%÷75%	1380÷12490*	13820÷16650*

* air capacities of the units with three-phase motors connected in Δ .

The range of adjusting the fresh air air damper in total air efficiency depending on different closing angles of circulating air grids

Fresh air damper adjustment range	Closing angle of circulating valves grids	% of fresh air participation in total air flow
open-close	0°	1.5% ÷ 57%
open-close	30°	3.5% ÷ 62%
open-close	45°	5% ÷ 67%
open-close	60°	10% ÷ 75%
open-close	75°	17% ÷ 83%

If the extension of participation adjustment from 100% of fresh air to 100% of circulating air is required it is planned to replace the standard intake boxes with the circulating air grids with the boxes with the air dampers (2 pcs) of increased tightness and with actuators.

CS WALL AIR INTAKE

Wall air intakes are intended for drawing fresh air from outside of the wall.

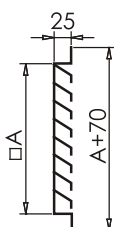

Unit size	Intake size	□ A	Weight [kg]
FHTERM0	CS-0	470	6
FHTERM1	CS-1	520	7
FHTERM2	CS-2	660	10
FHTERM3	CS-3	720	11
FHTERM4	CS-4	810	13

Wall intake vents are made of steel sheets protected with the paint coatings.

Presentation of % participation of fresh air, for which wall intakes of dimensions equal with intake boxes meet the condition of air inlet velocity less than 2,5 m/s it means: they will not suck the rain.

Unit size	A [mm]	Intake surface [m ²]	Total air flow [m ³ /h]	Fresh air flow at V<2,5m/s [m ³ /h]	Fresh air flow / Total air flow
FHTERM0	470	0,22	1000	2000	> 100 %
FHTERM1	520	0,27	2340	2450	> 100 %
FHTERM2	660	0,43	5400	3900	72%
FHTERM3	720	0,52	9450	4700	50%
FHTERM4	810	0,66	16650	5940	36%

TERM 0&1 units can operate totally on the outdoor air with the wall intakes dimensions equal with the cross-sections of the intake boxes.
 For the TERM 2, 3 and 4 units and operated totally on the outdoor air the wall intakes are selected by the manufacturer (wall intakes will have the bigger surfaces area).

ADDITIONAL EQUIPMENT

MOUNTING SETS

We can supply following mounting sets for the units:

Unit size	Mounting set type			
	Heating function		Heating and ventilating function	
	Wall units	Ceiling units	Wall units	Ceiling units
FHTERM0 FHTERM1 FHTERM2	EZ hanging elements set	EZ hanging elements set	GW, GWt suspesion set or WW, WWt support set	hanging on the threaded bars
FHTERM3 FHTERM4	G suspesion set	hanging on the threaded bars	GW, GWt suspesion set or WW, WWt support set	hanging on the threaded bars

TERM 0; 1; 2 (heating function)

Wall and ceiling units

Set of elements for hanging the unit includes:

- > angle bars mounted to the building partition – 2 pcs;
- > channel bars for hanging the unit - 6 pcs.

Unit can operate in vertical position or inclined from plumb-line up to 20°.

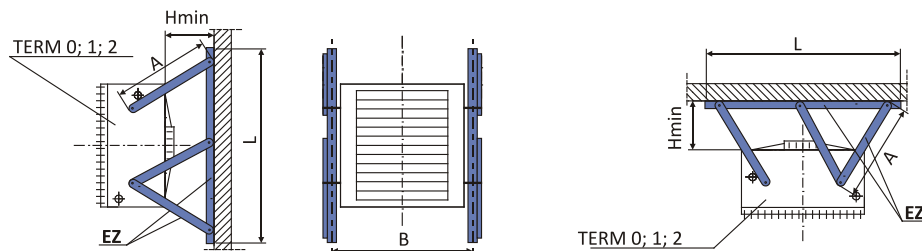

EZ hanging elements set				
Unit size	A	B	L	Hmin
FHTERM0	358	470	800	160
FHTERM1	470	620	990	180
FHTERM2	575	740	1140	230

All dimensions are stated in mm.

FHTERM 0; 1; 2 (heating and ventilation function)
Wall units

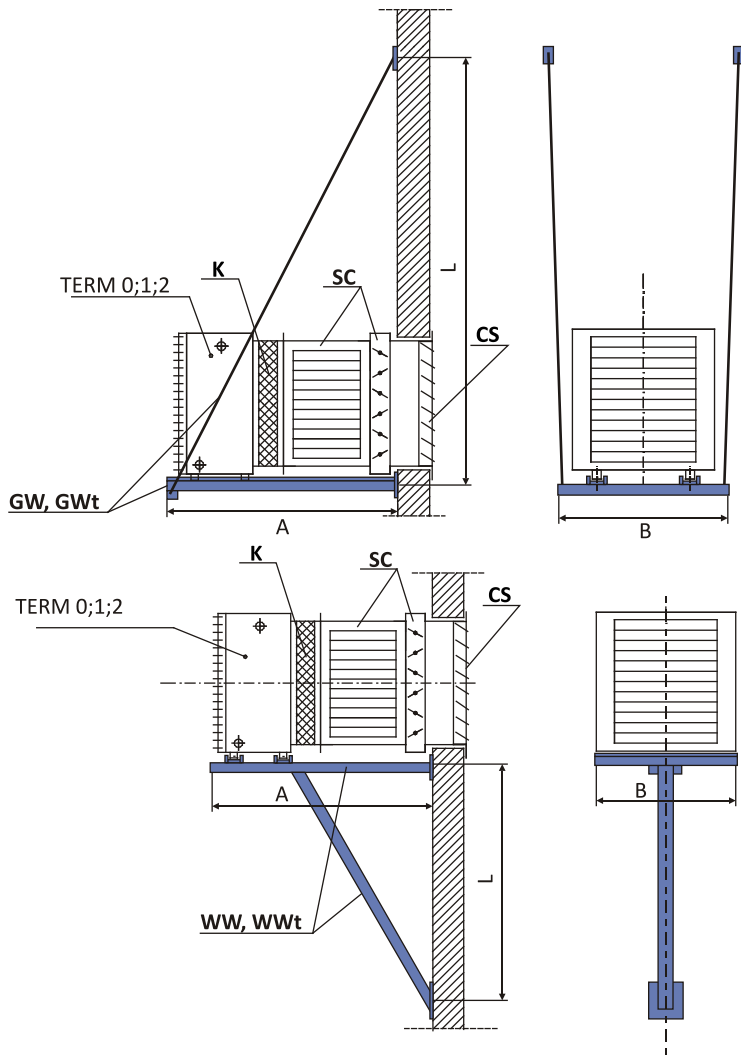

FHTERM 0, 1 & 2

GW suspension set - intake box without filter			
Unit size	A	B	L
FHTERM0	790	550	~1230
FHTERM1	880	700	~1315
FHTERM2	1000	820	~1520
GWt suspension set - intake box with filter			
FHTERM0	940	550	~1490
FHTERM1	1030	700	~1575
FHTERM2	1150	820	~1780

CS - wall intake
 SC - intake box
 K - flexible connector

WW support set - intake box without filter			
Unit size	A	B	L
FHTERM0	790	360	~810
FHTERM1	880	560	~930
FHTERM2	1000	680	~1030
WWt support set - intake box with filter			
FHTERM0	940	360	~810
FHTERM1	1030	560	~930
FHTERM2	1150	680	~1030

CS - wall intake
 SC - intake box
 K - flexible connector

FHTERM 0,1 & 2 (heating and ventilation function)
Ceiling units

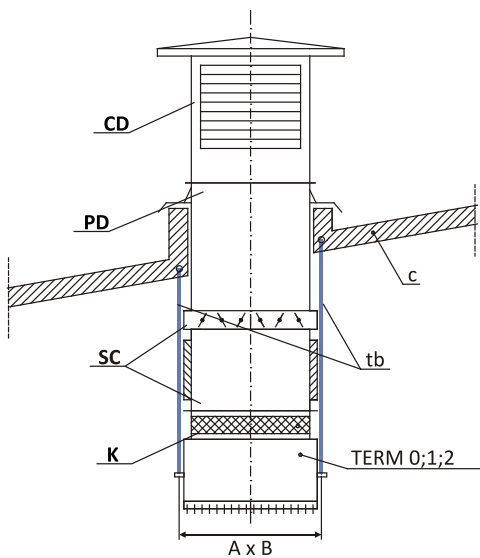

FHTERM 0, 1 & 2

Unit size	A x B
FHTERM0	570x200
FHTERM1	620x290
FHTERM2	760x380

CD - roof intake
 PD - roof base
 SC - intake box
 K - flexible connector
 c - ceiling
 tb - threaded bars

All dimensions are stated in mm.

FHTERM 3; 4 (heating function)
Wall units

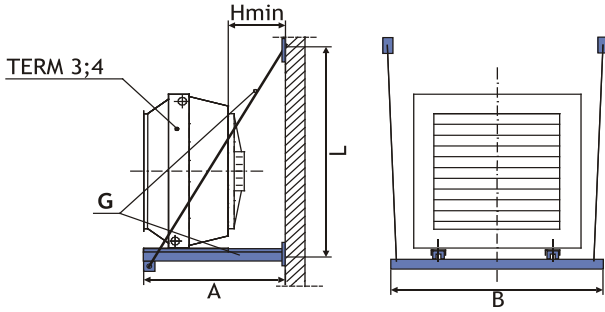

FHTERM 3; 4

G suspension set				
Unit size	A	B	L	Hmin
FHTERM-3	800	1200	1300	280
FHTERM-4	850	1550	1375	320

FHTERM 3; 4 (heating function)
Ceiling units

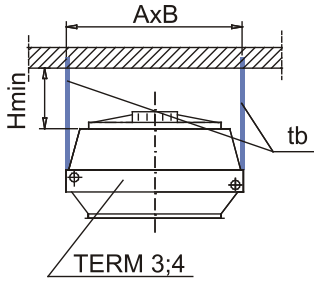

FHTERM 3; 4

Unit size	A x B	Hmin
FHTERM-3	860 x 987	280
FHTERM-4	1080 x 1227	320

tb - threaded bars / резьбовые стержни

FHTERM 3; 4 (heating and ventilation function)
Wall units

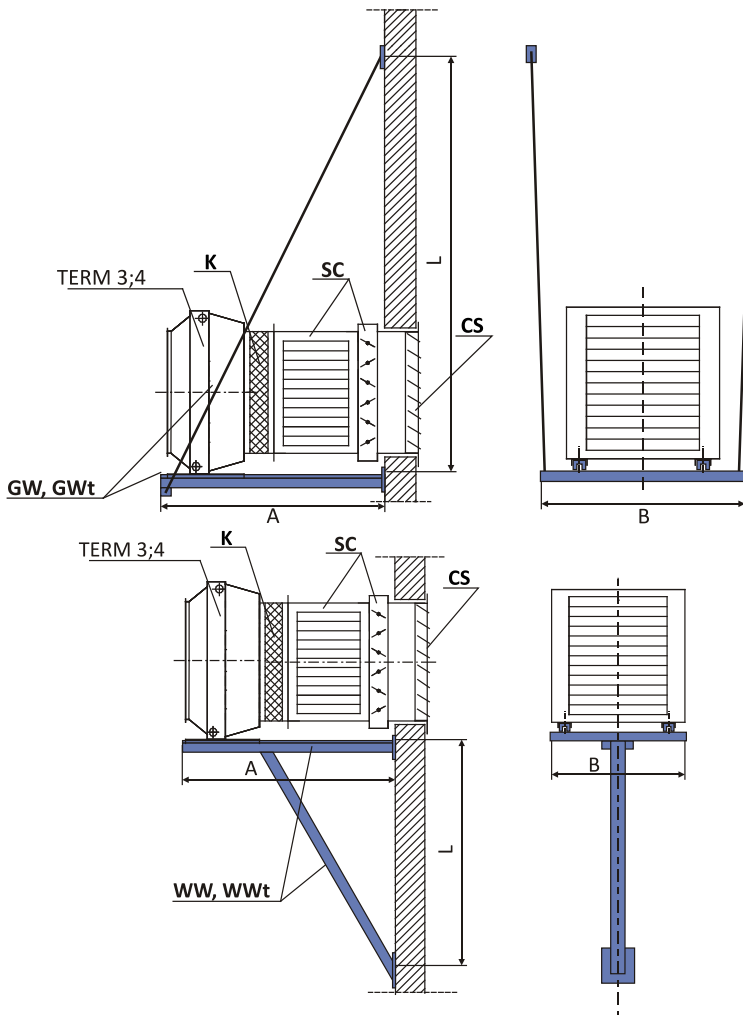

FHTERM 3; 4

GW suspension set - intake box without filter			
Unit size	A	B	L
FHTERM3	1300	1200	~2170
FHTERM4	1450	1550	~2415
GWt suspension set - intake box with filter			
FHTERM3	1450	1200	~2430
FHTERM4	1600	1550	~2675

CS - wall intake
SC - intake box
K - flexible connector

WW support set - intake box without filter			
Unit size Типоразмер агрегата	A	B	L
FHTERM3	1300	800	~1290
FHTERM4	1450	1000	~1425
WWt support set - intake box with filter			
FHTERM3	1450	800	~1290
FHTERM4	1600	1000	~1425

CS - wall intake
SC - intake box
K - flexible connector

All dimensions are stated in mm.

FHTERM 3; 4 (heating and ventilation function)
Ceiling units

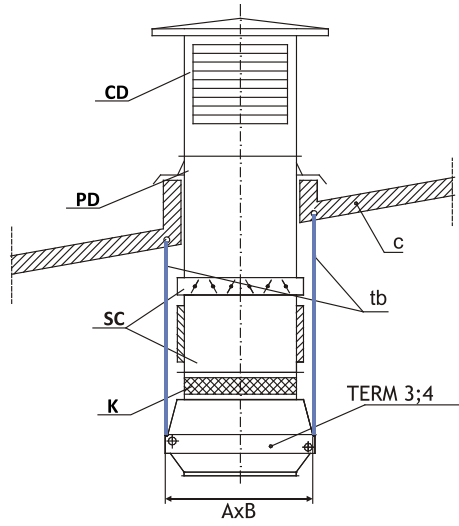

All dimensions are stated in mm.

FHTERM 3; 4

Unit size	A x B
FHTERM-3	860x984
FHTERM-4	1080x1224

- CD - roof intake
- PD - roof base
- SC - intake box
- K - flexible connector
- c - ceiling
- tb - threaded bars