

BA PLUS



- Simple installation and quick start-up heaters.
- Complete with **pre-assembled plenum** for direct air diffusion.
- **Diesel burner with built-in tank** and thermostat.
- Simply connect electrical power supply and the smoke outlet to start the appliance in few minutes.
- **Range of 3 models** with powers of 30 kW, 60 kW and 100 kW.
- Low noise level centrifugal fan.
- Ideal for heating of small and medium-sized industrial environments such as workshops, laboratories, emergency facilities where a reliable, autonomous, rapid and easy installation is required.

BA PLUS warm air heaters are the ideal solution for heating of small and medium-sized industrial environments where direct diffusion of warm is requested, without duct diffusion system.

Heaters are powered by diesel **single-stage burner**. The standard supply of air diffusion **plenum with adjustable outlet fins on all four sides** and a fixed transmission fan unit helps to make installation particularly economical, quick and simple.

The centrifugal fan, with motor directly coupled to the impeller and with **low noise emission level**, allows the installation of the heater directly into the environment to be treated.

The burner is contained in a special compartment, where the diesel tank is also housed. On the control panel there is a room thermostat to ensure fully automatic operation of the heater. The heater is complete with electrical panel and control and safety devices and, during summer season, it is set up to provide only ventilation of the environment.

For the biggest model BA 100 PLUS diesel tank is sold separately as accessory.

Technical features

HEATING SECTION

HEAT EXCHANGER

Models	U.M.	BA 30 PLUS	BA 60 PLUS	BA 100 PLUS
Thermal power input	kW	27,1	61,3	99,3
	kcal/h	23.300	52.720	85.400
Thermal power output	kW	25,2	56,7	92,3
	kcal/h	21.650	48.760	79.400
Air temperature increase	K	27	32	31
Diesel tank capacity	l	75	90	-

AEREAULIC SECTION

Models	U.M.	BA 30 PLUS	BA 60 PLUS	BA 100 PLUS
Nominal air flow	Nm ³ /h	2.760	5.300	8.800
Fan motor	W	245	560	2.200

ELECTRICAL SPECIFICATION

Models	U.M.	BA 30 PLUS	BA 60 PLUS	BA 100 PLUS
Electric voltage	V-50Hz	230 1 N~	230 1 N~	400 3 N~

Dimensions

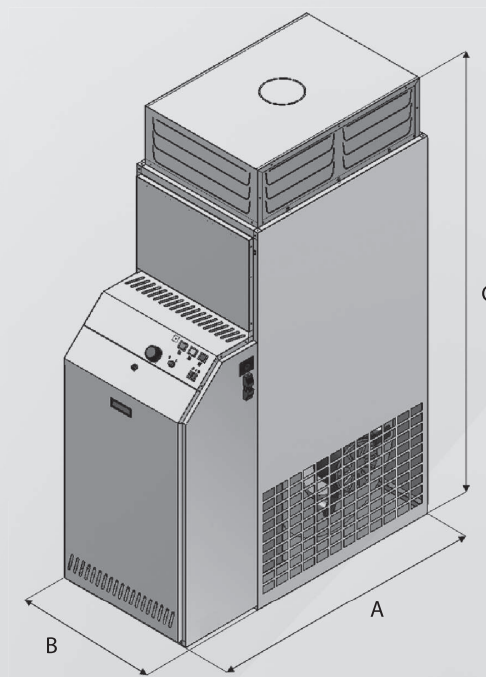

BA PLUS 30 ÷ 100

Models	Overall dimensions mm			Chimney Ø mm	Weight Kg*	Weight with packaging Kg
	A	B	C			
BA 30 S	1.020	500	1.600	120	140	150
BA 60 S	1.120	540	1.700	150	180	190
BA 100 S	1.400	760	2.000	200	315	325

* Without burner